

# INSTALLATION INSTRUCTIONS

## FOR UPFLOW CONDENSING MODULATING, COMMUNICATING GAS FURNACES W/ECM BLOWER (-)98V SERIES

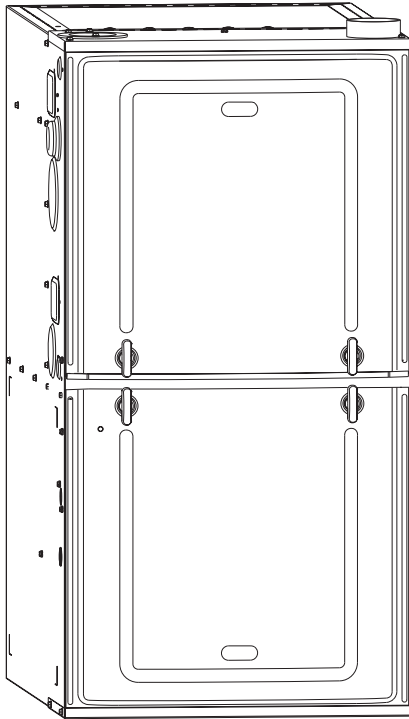

**RECOGNIZE THIS SYMBOL AS AN INDICATION OF IMPORTANT SAFETY INFORMATION!**

### ▲ WARNING

IF THE INFORMATION IN THESE INSTRUCTIONS IS NOT FOLLOWED EXACTLY, A FIRE OR EXPLOSION MAY RESULT CAUSING PROPERTY DAMAGE, PERSONAL INJURY OR DEATH.

### ▲ WARNING

THESE INSTRUCTIONS ARE INTENDED AS AN AID TO QUALIFIED SERVICE PERSONNEL FOR PROPER INSTALLATION, ADJUSTMENT AND OPERATION OF THIS UNIT. READ THESE INSTRUCTIONS THOROUGHLY BEFORE ATTEMPTING INSTALLATION OR OPERATION. FAILURE TO FOLLOW THESE INSTRUCTIONS MAY RESULT IN IMPROPER INSTALLATION, ADJUSTMENT, SERVICE OR MAINTENANCE, POSSIBLY RESULTING IN FIRE, ELECTRICAL SHOCK, CARBON MONOXIDE POISONING, EXPLOSION, PROPERTY DAMAGE, PERSONAL INJURY OR DEATH.

### ▲ WARNING

#### CARBON-MONOXIDE POISONING HAZARD

FAILURE TO FOLLOW INSTRUCTIONS COULD RESULT IN SEVERE PERSONAL INJURY OR DEATH DUE TO CARBON-MONOXIDE POISONING, IF COMBUSTION PRODUCTS INFILTRATE INTO THE BUILDING.

CHECK THAT ALL OPENINGS IN THE OUTSIDE WALL AROUND THE VENT (AND AIR INTAKE) PIPE(S) ARE SEALED TO PREVENT INFILTRATION OF COMBUSTION PRODUCTS INTO THE BUILDING.

CHECK THAT FURNACE VENT (AND AIR INTAKE) TERMINAL(S) ARE NOT OBSTRUCTED IN ANY WAY DURING ALL SEASONS.

### ▲ WARNING

- Do not store or use gasoline or other flammable vapors and liquids, or other combustible materials in the vicinity of this or any other appliance.
- WHAT TO DO IF YOU SMELL GAS
  - Do not try to light any appliance.
  - Do not touch any electrical switch; do not use any phone in your building.
  - Immediately call your gas supplier from a neighbor's phone. Follow the gas supplier's instructions.
  - If you cannot reach your gas supplier, call the fire department.
  - Do not return to your home until authorized by the gas supplier or fire department.
- DO NOT RELY ON SMELL ALONE TO DETECT LEAKS. DUE TO VARIOUS FACTORS, YOU MAY NOT BE ABLE TO SMELL FUEL GASES.
  - U.L. and/or C.S.A. recognized fuel gas and CO (carbon monoxide) detectors are recommended in all applications, and their installation should be in accordance with the manufacturer's recommendations and/or local laws, rules, regulations, or customs.
- Improper installation, adjustment, alteration, service or maintenance can cause injury property damage or death. Refer to this manual. Installation and service must be performed by a qualified installer, service agency or the gas supplier. In the commonwealth of Massachusetts, installation must be performed by a licensed plumber or gas fitter for appropriate fuel.

B100002

**DO NOT DESTROY THIS MANUAL. PLEASE READ CAREFULLY AND KEEP IN A SAFE PLACE FOR FUTURE REFERENCE BY A SERVICEMAN.**



# TABLE OF CONTENTS

<b>1</b>	<b>TABLE OF CONTENTS</b>	<b>2</b>
<b>2</b>	<b>GENERAL INFORMATION</b>	<b>3</b>
	Receiving	4
	Material Information	4
	Efficiency Testing Notice	4
	Checklist	5
<b>3</b>	<b>SAFETY INFORMATION</b>	<b>6</b>
	Warnings	6
	Important Information About Efficiency and Quality	7
	Commonwealth of Massachusetts Note	8
<b>4</b>	<b>LOCATION REQUIREMENTS</b>	<b>9</b>
	Freeze Protection	9
	Site Selection	9
	Clearance Accessibility	10
	Clearance Table	11
<b>5</b>	<b>FIELD CONVERSIONS</b>	<b>12-18</b>
	General Conversion Instructions and Tips	12
	Lists of Materials for Parts Bag and Conversion Kits	13
	Conversion Table of Contents	14
	Upflow with Vertical Vent	15-16
	Upflow with Left Side Vent	17-18
<b>6</b>	<b>DUCTING</b>	<b>19</b>
	Airflow Summary	22
<b>7</b>	<b>VENTING</b>	<b>23</b>
	General Venting Requirements and Guidelines (All Instructions)	23
	Venting and Combustion Air Piping Requirements	23
	Piping Requirements	24
	Vent Pipe Sizing and Maximum Lengths	24
	Equivalent Vent Length	26
	Polypropylene Vent Products	28
	Termination Requirements	29
	<b>Non-Direct Venting</b>	<b>30</b>
	Furnace Located in an Unconfined Space	30
	Furnace Located in a Confined Space	30
	Non-Direct Venting Terminations	33
	<b>Direct Venting</b>	<b>34</b>
	<u>Option 1:</u> Standard Vertical Direct Vent Termination	34
	<u>Option 2:</u> Standard Horizontal Direct Vent Termination	36
	<u>Option 3:</u> Variant of Standard Horizontal Direct Vent Termination	36
	<u>Option 4:</u> Alternate Horizontal Direct Vent Termination	37
	<u>Option 5:</u> Variant of Alternate Horizontal Direct Vent Termination	37
	Optional Termination Angles for Alt. Horizontal and Variant of Alt. Horizontal Direct-Vent Terminations (Options 4 and 5)	38
	<u>Option 6 &amp; 7:</u> Vertical and Horizontal Concentric Vent Termination (RXGY-E02A and RXGY-E03A)	39
	<u>Options 8 &amp; 9:</u> Sidewall Vent Kit for Direct Vent Termination (RXGY-G02 & RXGY-G01)	40
	Direct Venting Termination Clearances	40
	Multiventing of Direct Vent Furnaces	42
<b>8</b>	<b>CONDENSATE DRAIN AND DRAIN NEUTRALIZER</b>	<b>43</b>
<b>9</b>	<b>GAS SUPPLY AND PIPING</b>	
	Gas Supply	45
	Gas Piping	46
	Gas Pressure	47
	Gas Valve	48
<b>10</b>	<b>LP CONVERSION</b>	<b>48</b>
<b>11</b>	<b>FURNACE ADJUSTMENTS</b>	<b>51</b>
	Orifice Selection/Altitude Adjustment	51
	Adjust The Gas Pressure	52
	Verify The Input Rate	55
	Adjust The Gas Heat Temperature Rise	56
	Temperature Rise Verification	57
<b>12</b>	<b>ELECTRICAL WIRING</b>	<b>58</b>
	Reversing the Electrical Connection	58
	Thermostat	59
<b>13</b>	<b>ACCESSORIES</b>	<b>60</b>
	Electronic Air Cleaner	60
	Humidifier	60
	Filters	60
	Twinning (Not Permitted)	60
	Air Temperature Sensors	60
<b>14</b>	<b>CALIBRATION SEQUENCE OF OPERATIONS</b>	<b>62</b>
<b>15</b>	<b>START-UP AND SEQUENCE OF OPERATIONS</b>	<b>63</b>
<b>16</b>	<b>INTEGRATED FURNACE CONTROL</b>	<b>68</b>
	Humidification/Dehumidification	68
	Dipswitches	70
	Dual 7-Segment Display	73
	Pushbutton	74
	Supply & Outdoor Air Temp Sensors	76
	Thermostat Inputs	77
	Auxiliary Inputs	78
	Thermostat Wiring Diagrams-Communicating Non-Communicating	79-80
<b>17</b>	<b>TIMING DIAGRAM</b>	<b>86</b>
<b>18</b>	<b>MAINTENANCE</b>	<b>88</b>
	Filters	88
	Lubrication	88
	System Operation Information	89
	Annual Inspection	89
	Replacement Parts	89
<b>19</b>	<b>DIAGNOSTICS AND TROUBLESHOOTING</b>	<b>90</b>
	Normal Operation Codes	90
	Fault Codes with Descriptions and Solutions	91-100
	Lockout	101
	Replacing the Furnace Control	101
	Diagnosing Blower Motor Issues	102
	Wiring Diagram	104

# GENERAL INFORMATION

**NOTE:** A heat loss calculation should be performed to properly determine the required furnace BTU size for the structure. Also, the duct must be properly designed and installed for proper airflow. Existing ductwork must be inspected for proper size and to make sure that it is properly sealed. Proper airflow is necessary for both user comfort and equipment performance.

**Before opening the furnace carton, verify that the data tags on the carton specify the furnace model number that was ordered from the distributor and are correct for the installation. If not, return the unit without opening the carton. If the model number is correct, open the carton and verify that the furnace rating label specifies the same furnace model number that is specified on the carton label. If the model numbers do not match, return the furnace to the distributor.**

**IMPORTANT:** Proper application, installation and maintenance of this furnace and system is a must if consumers are to receive the full benefits for which they have paid.

The 98% modulating furnaces are design-certified by CSA for use with natural and propane gases as follows:

1. As non-direct vent central forced air furnaces taking combustion air from the installation area or using air ducted from the outside.
2. As direct vent central forced air furnaces with all combustion air supplied directly to the furnace burners through a special air intake system outlined in these instructions. Install this furnace in accordance with the American National Standard Z223.1 – latest edition entitled “National Fuel Gas Code” (NFPA54) or, for Canada, CSA B149.1; Canadian Natural Gas and Propane Installation Code and requirements or codes of the local utilities or other authorities having jurisdiction. This is available from the following:

National Fire Protection Association, Inc.  
Batterymarch Park  
Quincy, MA 02269

CSA-INTERNATIONAL  
5060 Spectrum Way  
Mississauga, Ontario  
Canada L4W5N6  
Online: [www.csa.ca](http://www.csa.ca)

**FIGURE 1**  
FURNACE COMPONENTS

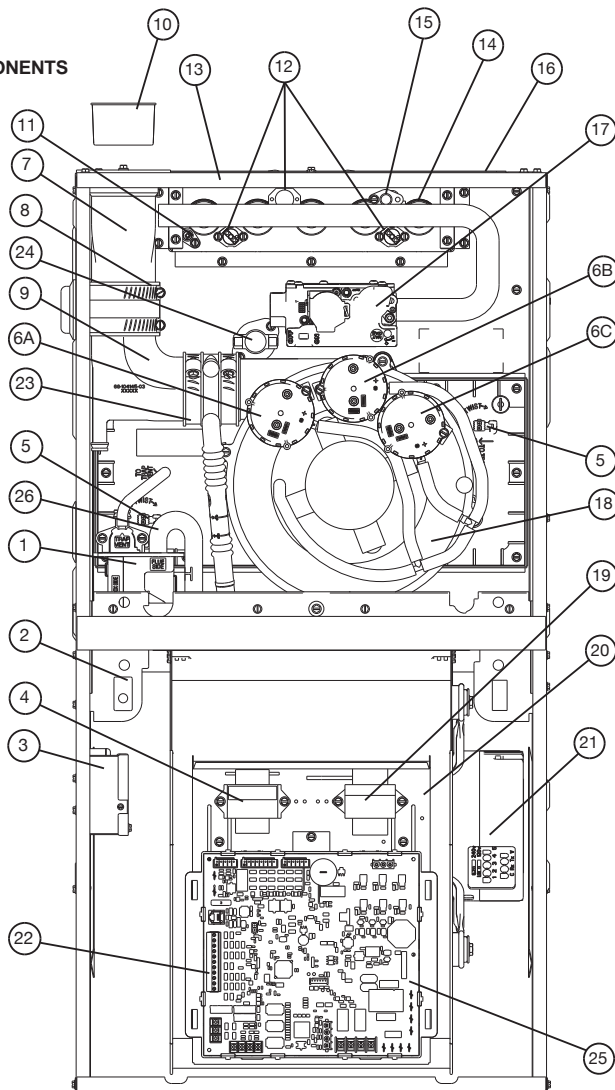

ITEM NO.	DESCRIPTION
1.	CONDENSATE TRAP
2.	DOOR SWITCH
3.	JUNCTION BOX
4.	TRANSFORMER
5.	WATER SENSOR (2)
6.	PRESSURE SWITCH STAGES
	A. HIGH
	B. MEDIUM
	C. LOW
7.	EXHAUST TRANSITION
8.	COUPLING (ELBOW TO TRANSITION)
9.	EXHAUST
10.	SHIPPING PLUG
11.	FLAME SENSOR
12.	OVER TEMPERATURE SWITCH
13.	TOP PLATE
14.	BURNER
15.	IGNITER
16.	COMBUSTION AIR INLET
17.	GAS VALVE
18.	INDUCED DRAFT BLOWER (IDB)
19.	POWER FACTOR CORRECTION CHOKE (PFC) (NOT USED ON THE 60K BTU AND 70K BTU)
20.	CONTROL MOUNTING PLATE
21.	BLOWER
22.	LOW VOLTAGE TERMINAL
23.	COUPLING (IDB TO ELBOW)
24.	MAIN LIMIT
25.	FURNACE CONTROL
26.	AUXILIARY TRAP

ST-A1194-67-00

# GENERAL INFORMATION (cont.)

In Canada installations must comply with CSA B149.1.

Install units in Canada in accordance with CSA-B149, local installation codes and authorities having jurisdiction. CSA-B149.1 is available from:

CSA INTERNATIONAL  
5060 Spectrum Way  
Mississauga, Ontario  
Canada L4W 5N6

online: [www.csa.ca](http://www.csa.ca)

**NOTICE:** Any equipment immersed in water (including by flooding) must be replaced. Equipment and products immersed in water will have operation adversely affected thereby voiding the warranty.

## RECEIVING

Immediately upon receipt, all cartons and contents should be inspected for transit damage. Units with damaged cartons should be opened immediately. If damage is found, it should be noted on the delivery papers, and a damage claim filed with the last carrier.

- After unit has been delivered to job site, remove carton taking care not to damage unit.
- Check the unit rating plate to be sure equipment matches job specifications.
- Read the entire instructions before starting the installation.
- Install the unit in such a way as to allow necessary access for service.
- Always remove the solid metal base pan from the top of the furnace. The base pan is installed in this location for shipping purposes only and should never remain in the as-shipped location after installation.
- Install the unit with a ¼" to ½" forward slope (toward front) to ensure proper drainage.
- Install the unit in accordance with any local code which may apply and the national codes. Latest editions are available from: "National Fire Protection Association, Inc., Batterymarch Park, Quincy, MA 02269." These publications are:
  - ANSI/NFPA No. 70-(Latest Edition) National Electrical Code.
  - NFPA90A Installation of Air Conditioning and Ventilating Systems.
  - NFPA90B Installation of warm air heating and air conditioning systems.
  - In Canada CSA 22.2 Canadian Electrical Code.
  - In Canada CSA B149.1; Canadian Natural Gas and Propane Installation Code.

## MATERIAL INFORMATION

All manufacturer products meet current Federal OSHA Guidelines for safety. Most consumers are aware that products present safety and health risks, when improperly used, handled and maintained. More details are available at the Websites for OSHA (Occupational Safety and Health Administration), at [www.osha.gov](http://www.osha.gov).

## EFFICIENCY TESTING NOTICE

For purposes of verifying or testing efficiency ratings, the test procedure in Title 10 Appendix N to Subpart B of Part 430 (Uniform Test Method for Measuring the Energy Consumption of Furnices and Boilers) and the clarifying positions provided in the AHRI Operations Manual for Residential Furnaces that were applicable at the date of manufacture should be used for test set up and performance.

**Installation Instructions remain with the furnace as a reference guide to the servicing contractor. We recommend that performance and installation data be recorded for future reference on this sheet to meet service and warranty obligations so that job site information is available when required.**

## Installation Checklist

REFER TO INSTALLATION INSTRUCTIONS

### GAS SUPPLY

- \_\_\_\_\_ Correct pipe size (record size)
- \_\_\_\_\_ Correct supply pressure (during furnace operation) (record pressure)
- \_\_\_\_\_ Manifold pressure (record upstream pressure)
- \_\_\_\_\_ No gas leaks
- \_\_\_\_\_ L.P. Kit Number (if applicable) (record kit number)

### ELECTRICAL

- \_\_\_\_\_ 115 V.A.C. supply (Dedicated Circuit) (record voltage)
- \_\_\_\_\_ Polarity observed
- \_\_\_\_\_ Furnace properly grounded
- \_\_\_\_\_ Correct wire size (record type and gauge)

### FURNACE INSTALLATION

- \_\_\_\_\_ Correct clearance to combustibles (record clearance)
- \_\_\_\_\_ Correct clearance for service (at front) (record clearance)

### DUCT STATIC PRESSURE

- \_\_\_\_\_ in. w.c. on heating speed (record static pressure)
- \_\_\_\_\_ in. w.c. on cooling speed (record static pressure)
- \_\_\_\_\_ Air temperature rise in heat (record air temperature rise)
- \_\_\_\_\_ Air temperature rise in cool (record air temperature rise)

### CONDENSATE LINE

- \_\_\_\_\_ Trap filled with water
- \_\_\_\_\_ Vented
- \_\_\_\_\_ Sloped toward drain
- \_\_\_\_\_ Condensate drain line hoses connected and clamped
- \_\_\_\_\_ Freeze protection (if necessary)

### VENTING – DIRECT VENT

- \_\_\_\_\_ in. diameter – intake pipe (record diameter)
- \_\_\_\_\_ in. diameter – exhaust pipe (record diameter)
- \_\_\_\_\_ ft. of pipe – intake air (record length)
- \_\_\_\_\_ no. of elbows – intake air (record number of elbows)

- \_\_\_\_\_ ft. of pipe – exhaust pipe (record length)
- \_\_\_\_\_ no. of elbows – exhaust pipe (record number of elbows)
- \_\_\_\_\_ Exhaust Vent Temperature (record temperature)

### TERMINATIONS – DIRECT VENT

#### VERTICAL

- \_\_\_\_\_ Intake – 12" [305mm] min. above roof/snow level (record height above anticipated snow level) or, in Canada, intake and exhaust vents conform with CSA B149.1; Canadian Natural Gas and Propane Installation Code

- \_\_\_\_\_ Correct relationship – exhaust to intake

#### HORIZONTAL/VERTICAL – CONCENTRIC (RXGY-E03A)

- \_\_\_\_\_ Intake – 12" [305mm] min. above roof/snow level (record height above anticipated snow level) or, in Canada, intake and exhaust vents conform with CSA B149.1; Canadian Natural Gas and Propane Installation Code

- \_\_\_\_\_ Exhaust sloped down toward furnace

- \_\_\_\_\_ Correct distances (horizontal and vertical) – exhaust to intake

- \_\_\_\_\_ 12" [305mm] min. above grade/snow level (record height above anticipated snow level) or, in Canada, intake and exhaust vents conform with CSA B149.1; Canadian Natural Gas and Propane Installation Code

- \_\_\_\_\_ Above anticipated snow level (record maximum anticipated snow level)

### VENTING – NON-DIRECT VENT

- \_\_\_\_\_ in. diameter – exhaust pipe (record diameter)
- \_\_\_\_\_ ft. of pipe – exhaust (record length)
- \_\_\_\_\_ no. of elbows (record number of elbows)

### TERMINATION – NON-DIRECT VENT

#### VERTICAL

- \_\_\_\_\_ 12" [305mm] min. above roof/snow level (record height above anticipated snow level) or, in Canada, intake and exhaust vents conform with CSA B149.1; Canadian Natural Gas and Propane Installation Code

#### HORIZONTAL – STANDARD

- \_\_\_\_\_ 12" [305mm] min. above grade/snow level (record height above anticipated snow level) or, in Canada, intake and exhaust vents conform with CSA B149.1; Canadian Natural Gas and Propane Installation Code

# SAFETY INFORMATION

## WARNING

DO NOT INSTALL THIS FURNACE IN A MOBILE HOME! THIS FURNACE IS NOT APPROVED FOR INSTALLATION IN A MOBILE HOME. DOING SO COULD CAUSE FIRE, PROPERTY DAMAGE, PERSONAL INJURY OR DEATH.

## WARNING

INSTALL THIS FURNACE ONLY IN A LOCATION AND POSITION AS SPECIFIED IN THE LOCATION REQUIREMENTS AND CONSIDERATIONS SECTION OF THESE INSTRUCTIONS.

## WARNING

IMPROPER INSTALLATION, OR INSTALLATION NOT MADE IN ACCORDANCE WITH THE CSA INTERNATIONAL (CSA) CERTIFICATION OR THESE INSTRUCTIONS, CAN RESULT IN UNSATISFACTORY OPERATION AND/OR DANGEROUS CONDITIONS AND ARE NOT COVERED BY THE MANUFACTURER'S WARRANTY.

## WARNING

DO NOT BYPASS, JUMPER, OR REMOVE ANY SAFETY SWITCH FROM THE FURNACE CONTROL CIRCUIT. IF A SAFETY SWITCH CAUSES THE FURNACE TO SHUT DOWN OR OPERATE INTERMITTENTLY, IT IS AN INDICATION OF A POTENTIAL SAFETY HAZARD THAT MUST BE ADDRESSED BY A QUALIFIED TECHNICIAN, SERVICE AGENCY OR THE GAS SUPPLIER. DO NOT RESET SAFETY CONTROLS WITHOUT CORRECTIVE ACTION AND/OR VERIFICATION OF PROPER SAFE OPERATION BY A QUALIFIED INSTALLER, SERVICE AGENCY OR THE GAS SUPPLIER.

REPLACE ANY SAFETY CONTROL COMPONENT ONLY WITH IDENTICAL OEM REPLACEMENT PARTS. WHEN A NEW SAFETY SWITCH IS INSTALLED, IT MUST BE TESTED FOR A MINIMUM OF 15 MINUTES WITH THE FURNACE OPERATING AT MAXIMUM INPUT RATE AND WITH BOTH BLOWER AND BURNER DOOR INSTALLED. IF THE FURNACE IS INSTALLED IN A CLOSET, THE CLOSET DOOR MUST ALSO BE CLOSED FOR THIS TEST. REPEAT THE TEST AT THE MINIMUM INPUT RATE IF THE FURNACE IS A MULTI-STAGE FURNACE.

## WARNING

USE ONLY WITH THE TYPE OF GAS APPROVED FOR THIS FURNACE. REFER TO THE FURNACE RATING PLATE.

## WARNING

NEVER TEST FOR GAS LEAKS WITH AN OPEN FLAME. USE A COMMERCIALY AVAILABLE SOAP SOLUTION MADE SPECIFICALLY FOR THE DETECTION OF LEAKS TO CHECK ALL CONNECTIONS, AS SPECIFIED IN GAS SUPPLY AND PIPING SECTION OF THESE INSTRUCTIONS.

## WARNING

COMBUSTION AND VENTILATION AIR MUST BE PROVIDED TO THE FURNACE AS REQUIRED BY THE NATIONAL FUEL-GAS CODE (U.S.) AND CSA B149.1 (CANADA) AND THE COMBUSTION AND VENTILATION AIR SECTION OF THESE INSTRUCTIONS.

## WARNING

COMBUSTION PRODUCTS MUST BE DISCHARGED OUTDOORS. CONNECT THIS FURNACE TO AN APPROVED VENT SYSTEM ONLY, AS SPECIFIED IN THE VENT PIPE INSTALLATION SECTION OF THESE INSTRUCTIONS.

## WARNING

WHEN A FURNACE IS INSTALLED SO THAT SUPPLY DUCTS CARRY AIR CIRCULATED BY THE FURNACE TO AREAS OUTSIDE THE SPACE CONTAINING THE FURNACE, THE RETURN AIR SHALL ALSO BE HANDLED BY DUCT(S) SEALED TO THE FURNACE CASING AND TERMINATING OUTSIDE THE SPACE CONTAINING THE FURNACE.

## WARNING

WHENEVER THE FACTORY RETURN-AIR CONNECTION IS NOT USED IT MUST BE SEALED. A SOLID METAL BASE PLATE MUST BE INSTALLED AND SEALED. FACTORY BASE PLATES ARE AVAILABLE AS ACCESSORY ITEMS. (PART NUMBERS ARE LISTED IN THE SPEC SHEET FOR THE FURNACE.) FAILURE TO INSTALL AND SEAL THE BASE PLATE AND RETURN AIR DUCT CONNECTIONS MAY ALLOW CARBON MONOXIDE AND OTHER CONTAMINANTS TO BE DRAWN INTO THE CONDITIONED AIR SPACE AND DISTRIBUTED THROUGHOUT THE HEATED SPACE.

## WARNING

DO NOT OPERATE THE SYSTEM WITHOUT FILTERS. A PORTION OF THE DUST ENTRAINED IN THE AIR MAY TEMPORARILY LODGE IN THE AIR DUCT RUNS AND AT THE SUPPLY REGISTERS. ANY CIRCULATED DUST PARTICLES WILL BE HEATED AND CHARRED BY CONTACT WITH THE FURNACE HEAT EXCHANGER. THIS SOOTY RESIDUE WILL SOIL CEILINGS, WALLS, DRAPES, CARPETS AND OTHER HOUSEHOLD ARTICLES. SOOT DAMAGE MAY ALSO RESULT WITH, OR WITHOUT, FILTERS IN PLACE, WHEN CERTAIN TYPES OF CANDLES ARE BURNED, OR CANDLEWICKS ARE LEFT UNTRIMMED.

## WARNING

IN COMPLIANCE WITH RECOGNIZED CODES, IT IS RECOMMENDED THAT AN AUXILIARY DRAIN PAN BE INSTALLED UNDER THIS FURNACE AND ANY INSTALLED EVAPORATOR COIL THAT IS LOCATED IN ANY AREA OF A STRUCTURE WHERE DAMAGE TO THE BUILDING OR BUILDING CONTENTS MAY OCCUR AS A RESULT OF AN OVERFLOW OF THE FURNACE CONDENSATE DISPOSAL SYSTEM OR THE COIL DRAIN PAN OR A STOPPAGE IN THE PRIMARY CONDENSATE DRAIN PIPING.

## **! WARNING**

Furnaces May Be Used For Heating Buildings Or Structures Under Construction, If The Following Conditions Are Met To Ensure Proper Operation.

**DO NOT USE THE UNIT FOR CONSTRUCTION HEAT UNLESS ALL OF THE FOLLOWING CRITERIA ARE MET:**

- A) Furnace Must Be In Its Final Location. Per Installation Instructions, And The Vent System Shall Be Permanently Installed.
- B) Furnace Must Be Installed As A Two-Pipe System And Outdoor Air Must Be Used One Hundred Percent (100%) For Combustion Air Requirements During Construction
- C) A Room Thermostat Must Control The Furnace. The Use Of Fixed Jumpers Is Prohibited
- D) The Input Rate And Temperature Rise Must Be Set Per The Furnace Rating Plate
- E) Supply And Return Air Ducts Must Be Connected And Sealed To The Furnace. Return Air Must Terminate Outside Of The Space Where The Furnace Is Installed
- F) Return Air Temperature Range, Between 13°C (55°F) And 27°C (80°F), Must Be Maintained
- G) Merv 11 Or Greater Air Filters Must Be Installed In The Furnace System, And Must Be Regularly Inspected And Maintained During Construction. Regular Static Checks Must Be Performed And Filter Must Be Replaced At The End Of Life
- H) Blower And Vestibule Access Panels Must Be In Place On The Furnace At All Times
- I) Furnace Heat Exchanger, Components, Duct System And Evaporator Coils Must Be Cleaned Thoroughly Following Final Construction
- J) Air Filters Must Be Replaced Upon Construction Completion
- K) All Furnace Operating Conditions (Including Ignition, Input Rate, Temperature Rise And Venting) Must Be Verified In Accordance With The Installation Instructions

EQUIPMENT MAY EXPERIENCE PREMATURE COMPONENT FAILURE AS A RESULT OF NEGLIGENCE TO FOLLOW THE ABOVE INSTALLATION INSTRUCTIONS. FAILURE TO FOLLOW THE ABOVE INSTALLATION INSTRUCTIONS VOIDS THE MANUFACTURER'S EQUIPMENT LIMITED WARRANTY. RHEEM DISCLAIMS ALL LIABILITY IN CONNECTION WITH INSTALLER'S FAILURE TO FOLLOW THE ABOVE INSTALLATION INSTRUCTIONS.

NOTWITHSTANDING THE FOREGOING, INSTALLER IS RESPONSIBLE FOR CONFIRMING THAT THE USE OF CONSTRUCTION HEAT IS CONSISTENT WITH THE POLICIES AND CODES OF ALL REGULATING ENTITIES. MUST ADHERE TO ALL SUCH POLICIES AND CODES.

## IMPORTANT INFORMATION ABOUT EFFICIENCY AND INDOOR AIR QUALITY

Central cooling and heating equipment is only as efficient as the duct system that carries the cooled or heated air. To maintain efficiency, comfort and good indoor air quality, it is important to have the proper balance between the air

supplied to each room and the air returning to the cooling and heating equipment.

Proper balance and sealing of the duct system improves the efficiency of the heating and air conditioning system and improves the indoor air quality of the home by reducing the amount of airborne pollutants that enter homes from spaces where the ductwork and / or equipment is located. The manufacturer and the U.S. Environmental Protection Agency's Energy Star Program recommend that central duct systems be checked by a qualified contractor for proper balance and sealing.

## **! WARNING**

**DUCT LEAKS CAN CREATE AN UNBALANCED SYSTEM AND DRAW POLLUTANTS SUCH AS DIRT, DUST, FUMES AND ODORS INTO THE HOME CAUSING PROPERTY DAMAGE. FUMES AND ODORS FROM TOXIC, VOLATILE OR FLAMMABLE CHEMICALS, AS WELL AS AUTOMOBILE EXHAUST AND CARBON MONOXIDE (CO), CAN BE DRAWN INTO THE LIVING SPACE THROUGH LEAKING DUCTS AND UNBALANCED DUCT SYSTEMS CAUSING PERSONAL INJURY OR DEATH (SEE FIGURE 2).**

- IF AIR-MOVING EQUIPMENT OR DUCTWORK IS LOCATED IN GARAGES OR OFF-GARAGE STORAGE AREAS - ALL JOINTS, SEAMS, AND OPENINGS IN THE EQUIPMENT AND DUCT MUST BE SEALED TO LIMIT THE MIGRATION OF TOXIC FUMES AND ODORS INCLUDING CARBON MONOXIDE FROM MIGRATING INTO THE LIVING SPACE.
- IF AIR-MOVING EQUIPMENT OR DUCTWORK IS LOCATED IN SPACES CONTAINING FUEL BURNING APPLIANCES SUCH AS WATER HEATERS OR BOILERS - ALL JOINTS, SEAMS, AND OPENINGS IN THE EQUIPMENT AND DUCT MUST ALSO BE SEALED TO PREVENT DEPRESSURIZATION OF THE SPACE AND POSSIBLE MIGRATION OF COMBUSTION BYPRODUCTS INCLUDING CARBON MONOXIDE INTO THE LIVING SPACE.

## **! WARNING**

**BLOWER AND BURNERS MUST NEVER BE OPERATED WITHOUT THE BLOWER DOOR IN PLACE. THIS IS TO PREVENT DRAWING GAS FUMES (WHICH COULD CONTAIN HAZARDOUS CARBON MONOXIDE) INTO THE HOME THAT COULD RESULT IN PERSONAL INJURY OR DEATH.**

**FIGURE 2**  
MIGRATION OF DANGEROUS SUBSTANCES, FUMES, AND ODORS INTO LIVING SPACES

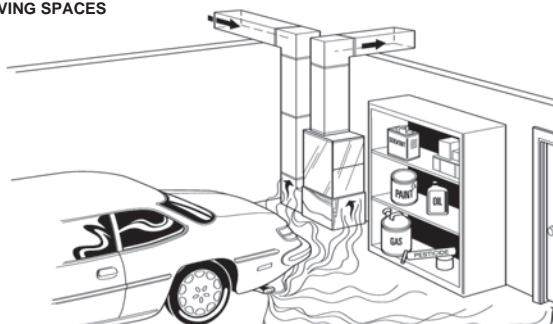

Adapted from *Residential Duct Diagnostics and Repair*, with permission of Air Conditioning Contractors of America (ACCA).

# COMMONWEALTH OF MASSACHUSETTS NOTE

## IMPORTANT! THE COMMONWEALTH OF MASSACHUSETTS REQUIRES COMPLIANCE WITH REGULATION 248 CMR 4.00 AND 5.00 FOR INSTALLATION OF THROUGH-THE-WALL VENTED GAS APPLIANCES AS FOLLOWS:

(a) For all side wall horizontally vented gas fueled equipment installed in every dwelling, building or structure used in whole or in part for residential purposes, including those owned or operated by the Commonwealth and where the side wall exhaust vent termination is less than seven (7) feet above finished grade in the area of the venting, including but not limited to decks and porches, the following requirements shall be satisfied:

**1. INSTALLATION OF CARBON MONOXIDE DETECTORS.** At the time of installation of the side wall horizontal vented gas fueled equipment, the installing plumber or gasfitter shall observe that a hard wired carbon monoxide detector with an alarm and battery back-up is installed on the floor level where the gas equipment is to be installed. In addition, the installing plumber or gasfitter shall observe that a battery operated or hard wired carbon monoxide detector with an alarm is installed on each additional level of the dwelling, building or structure served by the side wall horizontal vented gas fueled equipment. It shall be the responsibility of the property owner to secure the services of qualified licensed professionals for the installation of hard wired carbon monoxide detectors.

a. In the event that the side wall horizontally vented gas fueled equipment is installed in a crawl space or an attic, the hard wired carbon monoxide detector with alarm and battery back-up may be installed on the next adjacent floor level.

b. In the event that the requirements of this subdivision can not be met at the time of completion of installation, the owner shall have a period of thirty (30) days to comply with the above requirements; provided, however, that during said thirty (30) day period, a battery operated carbon monoxide detector with an alarm shall be installed.

**2. APPROVED CARBON MONOXIDE DETECTORS.** Each carbon monoxide detector as required in accordance with the above provisions shall comply with NFPA 720 and be ANSI/UL 2034 listed and IAS certified.

**3. SIGNAGE.** A metal or plastic identification plate shall be permanently mounted to the exterior of the building at a minimum height of eight (8) feet above grade directly in line with the exhaust vent terminal for the horizontally vented gas fueled heating appliance or equipment. The sign shall read, in print size no less than one-half (½) inch in size, “**GAS VENT DIRECTLY BELOW. KEEP CLEAR OF ALL OBSTRUCTIONS**”.

**4. INSPECTION.** The state or local gas inspector of the side wall horizontally vented gas fueled equipment shall not approve the installation unless, upon inspection, the inspector observes carbon monoxide detectors and signage installed in accordance with the provisions of 248 CMR 5.08(2)(a) 1 through 4.

(b) **EXEMPTIONS:** The following equipment is exempt from 248 CMR 5.08(2)(a)1 through 4:

1. The equipment listed in Chapter 10 entitled “Equipment Not Required To Be Vented” in the most current edition of NFPA 54 as adopted by the Board; and

2. Product Approved side wall horizontally vented gas fueled equipment installed in a room or structure separate from the dwelling, building or structure used in whole or in part for residential purposes.

(c) **MANUFACTURER REQUIREMENTS – GAS EQUIPMENT VENTING SYSTEM PROVIDED.** When the manufacturer of Product Approved side wall horizontally vented gas equipment provides a venting system design or venting system components with the equipment, the instructions provided by the manufacturer for installation of the equipment and the venting system shall include:

1. Detailed instructions for the installation of the venting system design or the venting system components; and
2. A complete parts list for the venting system design or venting system.

(d) **MANUFACTURER REQUIREMENTS – GAS EQUIPMENT VENTING SYSTEM NOT PROVIDED.** When the manufacturer of a Product Approved side wall horizontally vented gas fueled equipment does not provide the parts for venting the flue gases, but identifies “special venting systems”, the following requirements shall be satisfied by the manufacturer:

1. The referenced “special venting system” instructions shall be included with the appliance or equipment installation instructions; and
2. The “special venting systems” shall be Product Approved by the Board, and the instructions for that system shall include a parts list and detailed installation instructions.

(e) A copy of all installation instructions for all Product Approved side wall horizontally vented gas fueled equipment, all venting instructions, all parts lists for venting instructions, and/or all venting design instructions shall remain with the appliance or equipment at the completion of the installation.



# LOCATION REQUIREMENTS

## GENERAL INFORMATION

### **▲ WARNING**

**WHEN THIS FURNACE IS INSTALLED IN A RESIDENTIAL GARAGE, IT MUST BE INSTALLED SO THE BURNERS AND IGNITION SOURCE ARE LOCATED NO LESS THAN 18 INCHES [450MM] ABOVE THE FLOOR. THIS IS TO PREVENT THE RISK OF IGNITING FLAMMABLE VAPORS WHICH MAY BE PRESENT IN A GARAGE. ALSO, THE FURNACE MUST BE LOCATED OR PROTECTED TO AVOID PHYSICAL DAMAGE BY VEHICLES. FAILURE TO FOLLOW THESE WARNINGS CAN CAUSE A FIRE OR EXPLOSION, RESULTING IN PROPERTY DAMAGE, PERSONAL INJURY OR DEATH.**

1. **IMPORTANT:** If installing the unit over a finished ceiling or living area, be certain to install an auxiliary condensate drain pan under the entire unit. This auxiliary drain pan should extend under any evaporator coil installed with the furnace and the open portion of the condensate drain assembly. See “Condensate Drain/Neutralizer” section for more details.
2. **IMPORTANT:** If using a cooling evaporator coil with this furnace, be sure the air passes over the heat exchanger before passing over the cooling coil. The cooled air passing over the warm ambient air inside the heat exchanger tubes can cause condensation inside the tubes resulting in corrosion and eventual failure.

If these are manual dampers, they must be equipped to prevent heating or cooling operation unless the damper is in the full heat or cool position.

3. **IMPORTANT:** Furnace must be installed level from front-to-back or with a slight tilt such that the back of the furnace is up to ½” higher than the front of the furnace as shown in Figure 3.

**NOTE:** These furnaces are approved for installation in attics, as well as alcoves, utility rooms, closets and crawlspaces. Provisions must be made to prevent freezing of condensate.

### FREEZE PROTECTION

For installations where the furnace may reach temperatures below 32°F (0°C) (such as an alcove or attic installation), the installer must take precautions to ensure that the drain trap and connected drain pipe do not freeze. Local codes and practices should be followed in order to prevent freezing.

If the drain trap is installed within the furnace cabinet, no freeze protection is required. When the trap is mounted outside or partially outside the cabinet, it must be protected from freezing. Regardless of the location of the drain trap, any exposed drain piping must be protected from freezing as required by local practices or codes. A UL

or CSA listed heat tape or UL or CSA approved heating cable with a rating of 3-6 watts per foot is acceptable protection when installed and maintained in accordance with the manufacturer’s instructions. Good installation practices necessitate that the installer verify heat tape operation in accordance with the manufacturer’s instructions at the time of installation.

**IMPORTANT:** Support this unit when installed. Since this furnace is suitable for attic or crawl space installation, it may be installed on combustible wood flooring or by using support brackets as required.

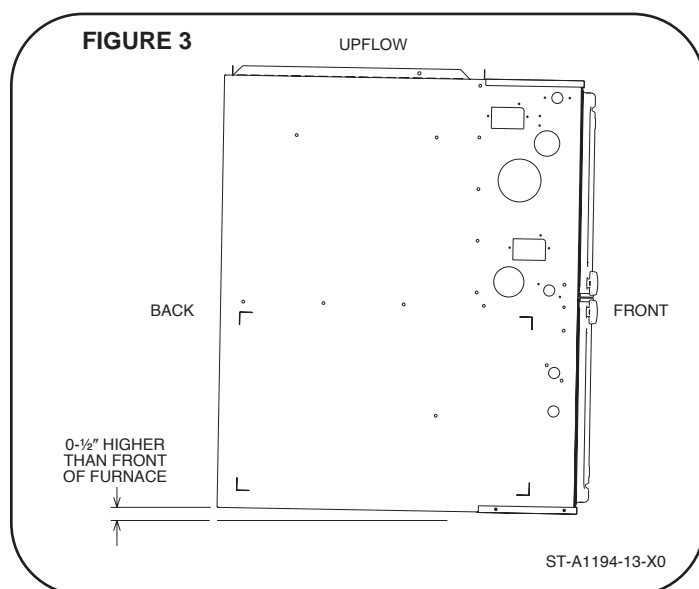

### **▲ WARNING**

**THIS FURNACE IS NOT APPROVED OR RECOMMENDED FOR INSTALLATION ON ITS BACK, WITH ACCESS DOORS FACING UPWARDS.**

### SITE SELECTION

1. Select a site in the building near the center of the proposed, or existing, duct system.
2. Give consideration to the vent system piping when selecting the furnace location. Be sure the venting system can get from the furnace to the termination with minimal length and elbows.
3. Locate the furnace near the existing gas piping. Or, if running a new gas line, locate the furnace to minimize the length and elbows in the gas piping.
4. Locate the furnace to maintain proper clearance to combustibles as shown in following Figure 5.

# LOCATION REQUIREMENTS

## GENERAL INFORMATION (cont.)

### **▲ WARNING**

DO NOT LIFT THE UNIT BY THE HEAT EXCHANGER TUBES. DOING SO CAN DAMAGE THE HEAT EXCHANGER ASSEMBLY.

### CLEARANCE – ACCESSIBILITY

The design of forced air furnaces with input ratings as listed in the tables under Figure 5 are certified by CSA-International for the clearances to combustible materials shown in inches.

See name/rating plate and clearance label for specific model number and clearance information.

Service clearance of at least 11" (27.9 cm) is recommended in front of all furnaces.

**NOTE:** Use recommended 11" (27.9 cm) clearance if accessibility clearances are greater than fire protection clearances.

### **▲ WARNING**

UPFLOW FURNACES ARE DESIGN- CERTIFIED FOR INSTALLATION ON COMBUSTIBLE FLOORS. NOTE, HOWEVER, THAT FURNACES MUST NOT BE INSTALLED DIRECTLY ON CARPETING, TILE OR OTHER COMBUSTIBLE MATERIAL OTHER THAN WOOD FLOORING. INSTALLATION ON A COMBUSTIBLE MATERIAL CAN RESULT IN FIRE, CAUSING PROPERTY DAMAGE, PERSONAL INJURY OR DEATH.

### **▲ WARNING**

COMBUSTIBLE MATERIAL MUST NOT BE PLACED ON OR AGAINST THE FURNACE JACKET. THE AREA AROUND THE FURNACE MUST BE KEPT CLEAR AND FREE OF ALL COMBUSTIBLE MATERIALS INCLUDING GASOLINE AND OTHER FLAMMABLE VAPORS AND LIQUIDS. PLACEMENT OF COMBUSTIBLE MATERIALS ON, AGAINST OR AROUND THE FURNACE JACKET CAN CAUSE AN EXPLOSION OR FIRE RESULTING IN PROPERTY DAMAGE, PERSONAL INJURY OR DEATH. THE HOMEOWNER SHOULD BE CAUTIONED THAT THE FURNACE AREA MUST NOT BE USED AS A BROOM CLOSET OR FOR ANY OTHER STORAGE PURPOSES.

**FIGURE 4** CLEARANCE FLUE VENT TO WALL

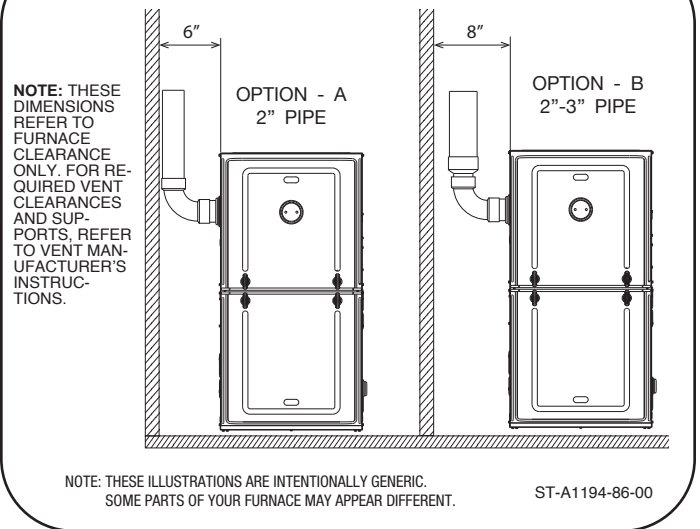

**FIGURE 5**  
**UNIT DIMENSIONS (CLEARANCE TO COMBUSTIBLES - SOME MEASUREMENTS DO NOT APPLY TO UPFLOWS)**

**UNIT DIMENSIONS  
(CLEARANCE TO COMBUSTIBLES)**

MODEL	LEFT SIDE	MINIMUM CLEARANCE (IN.)				SHIPPING WEIGHTS
		RIGHT	BACK	TOP	FRONT	
60K	0	0	0	1	2	0
70K	0	0	0	1	2	0
85K	0	0	0	1	2	0
100K	0	0	0	1	2	0
115K	0	0	0	1	2	0

\*A SERVICE CLEARANCE OF AT LEAST 24" IS RECOMMENDED IN FRONT OF ALL FURNACES

**FLANGE DIMENSIONS**

	A	B	C
17 1/2	16 17/64	16 13/64	
21	19 49/64	19 45/64	
24 1/2	23 17/64	23 13/64	

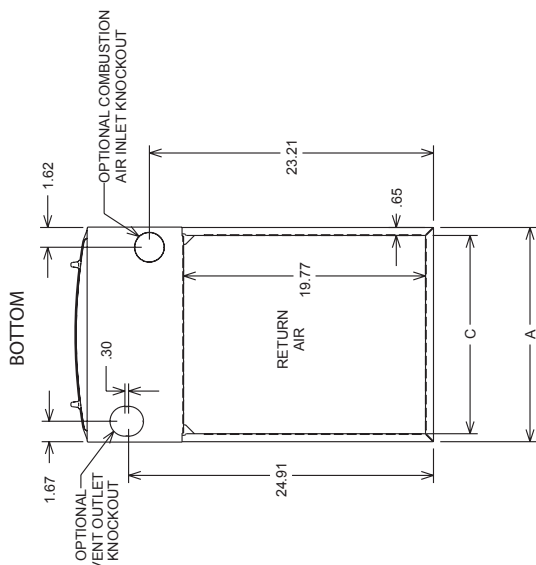
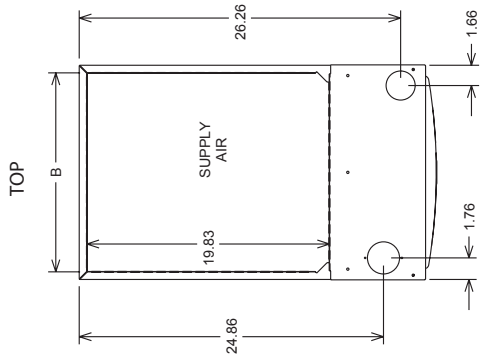

SUPPLY AND RETURN DEPICTED AS UPFLOW CONFIGURATION.  
FLANGE CONFIGURATION WILL VARY DEPENDING ON INSTALLATION ORIENTATION.

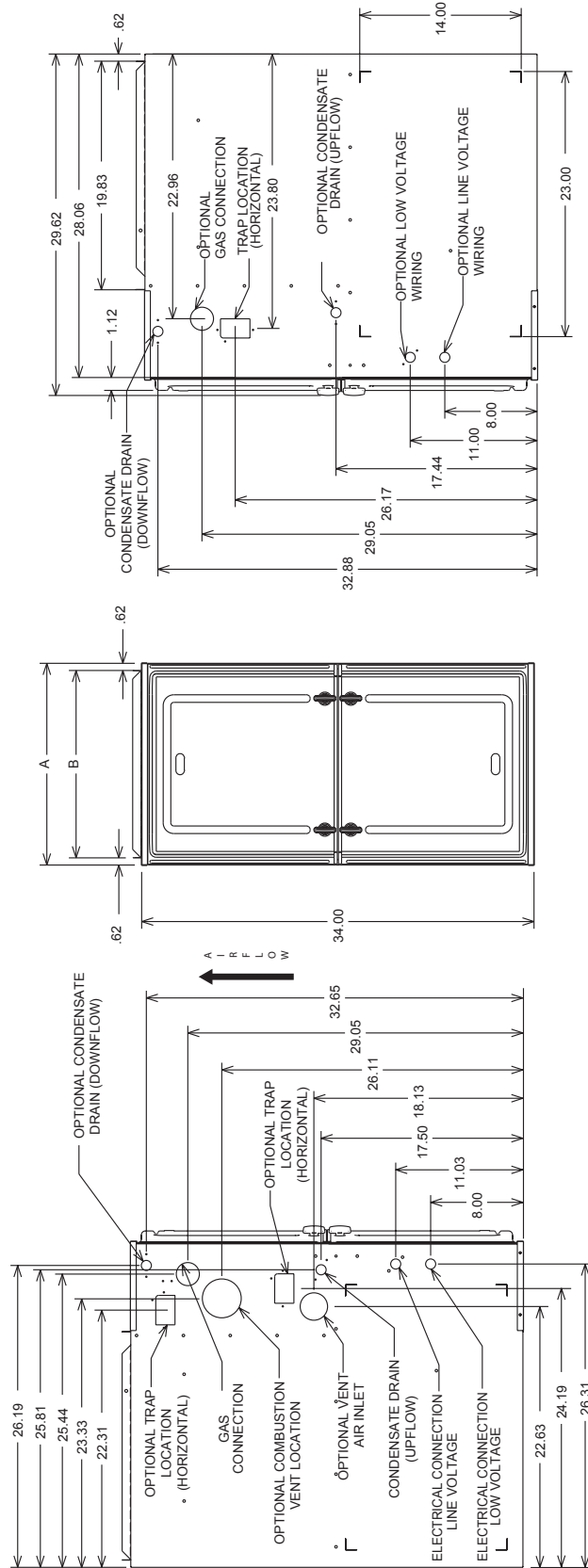

RIGHT SIDE

FRONT

LEFT SIDE

ST-A1194-01-X0

# FIELD CONVERSIONS

## GENERAL CONVERSION INSTRUCTIONS

### CONDENSATE PVC/HOSE OPTIONS

#### BULKHEAD COUPLING

CONDENSATE DRAINAGE HAS OPTIONS FOR 3/4" OR 1/2" PVC CONNECTIONS. THE BULKHEAD COUPLING CONNECTS THE RUBBER HOSES FROM INSIDE THE UNIT TO THE PVC PIPE EXTERIOR OF THE UNIT. PVC PIPE CAN BE CEMENTED DIRECTLY TO THE COUPLING AND THE TRAP WITH PROPER PVC CEMENT AND PRIMER.

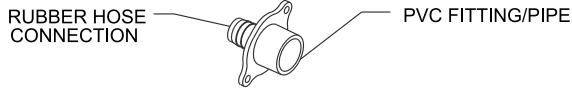

3/4" PVC COUPLING



3/4" PVC TEE



1/2" PVC PIPE

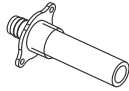

#### CONDENSATE TRAP

IN ADDITION TO PVC CONNECTIONS, THE CONDENSATE TRAP CAN ACCOMMODATE A 5/8" RUBBER HOSE WITH A HOSE CLAMP WHEN LOCATED INSIDE THE UNIT. PLIERS ARE NECESSARY TO ADD OR REMOVE CLAMP.

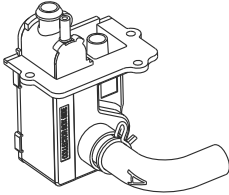

THE CONDENSATE TRAP HAS 2 SIDES PLEASE NOTE THEIR LOCATIONS FOR DRAIN CONNECTIONS DURING CONVERSION.

**NOTE: IMPROPER HOSE CONNECTIONS WILL PREVENT CONDENSATE FROM DRAINING.**

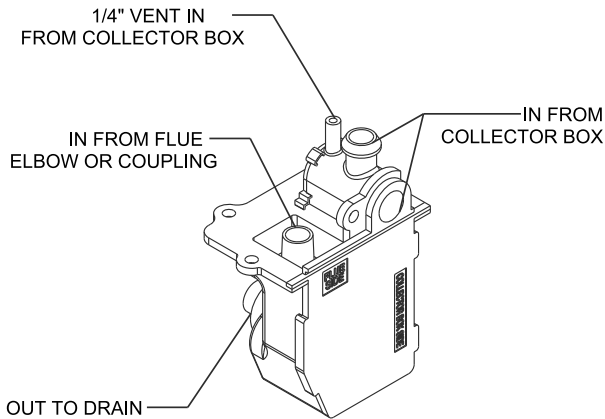

### CONVERSION AND INSTALLATION CONSIDERATIONS

ALL CONVERSIONS REQUIRE THE CONDENSATE PLUMBING TO HAVE DECLINE IN THE DIRECTION OF THE WATER FLOW.

WHEN INSTALLING AND MOVING CONDENSATE PLUMBING THE HOSES SHOULD BE FREE OF KINKS FOR PROPER WATER FLOW.

WHEN DRAIN HOSE OR CONDENSATE TRAP HOSE ROUTING CHANGES ARE NECESSARY BE SURE TO PLUG OR CAP ANY UNUSED HOSE TAPS.

THE INDUCER COUPLING COMES FROM THE FACTORY WITH A 10° TILT FOR UP FLOW INSTALLATIONS.

# FIELD CONVERSIONS

## GENERAL PARTS REQUIRED FOR CONVERSIONS

### PARTS BAG (PROVIDED WITH UNIT)

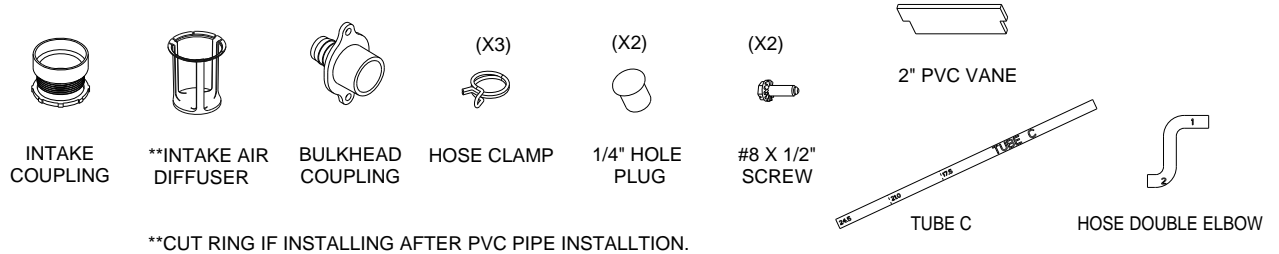

### CONVERSION KIT RXGY-CK

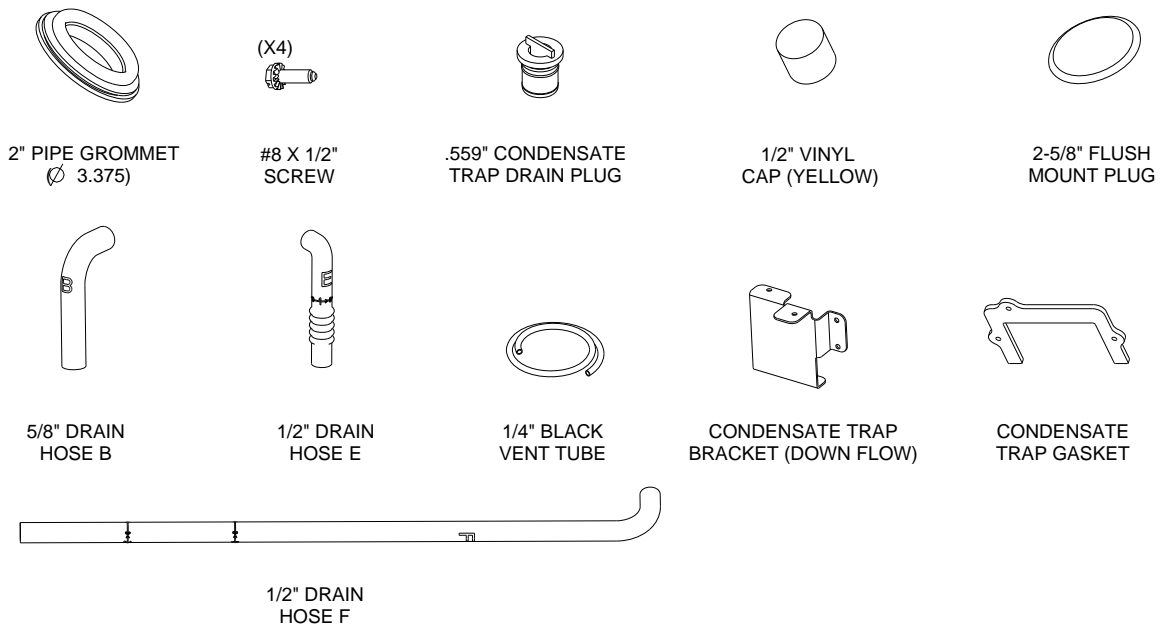

SEE NEXT PAGE FOR APPLICABLE CONFIGURATIONS

# FIELD CONVERSIONS

## FIELD CONVERSION TO VARIOUS CONFIGURATIONS

Furnaces can be converted to two different upflow configurations as follows. There are two different venting options, including a zero-clearance option, to give the installer flexibility in locating the venting for this furnace.

LISTS OF MATERIALS FOR PARTS BAGS AND CONVERSION KITS ..... Pg 12

GENERAL CONVERSION INSTRUCTIONS AND TIPS..... Pg 13

UPFLOW WITH VERTICAL VENT. .... Pg 15-16

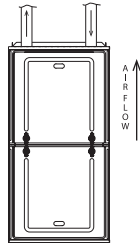

UPFLOW WITH LEFT SIDE VENT.  
(REQUIRES CONVERSION  
KIT RXGY-CK) ..... Pg 17-18

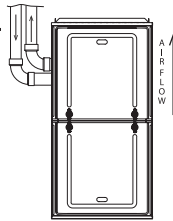

# UPFLOW VERTICAL VENT

## PARTS NEEDED:

 PARTS NEEDED FOR THIS CONVERSION REQUIRE ITEMS FROM THE **PARTS BAG** ONLY. NO OTHER CONVERSION KITS ARE NEEDED.

FROM PARTS BAG (PROVIDED WITH UNIT)

TUBE C

24.5" | 21.0" | 17.5" TUBE C

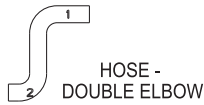

HOSE - DOUBLE ELBOW



HOSE CLAMP (X3)



#8 X 1/2" SCREW (X2)



BULKHEAD COUPLING



INTAKE COUPLING W/ NUT

## TOOLS/MATERIALS NEEDED:

DRILL                      1/8" DRILL BIT                      PLIERS  
1/4" HEX HEAD DRIVER                      TUBING CUTTER

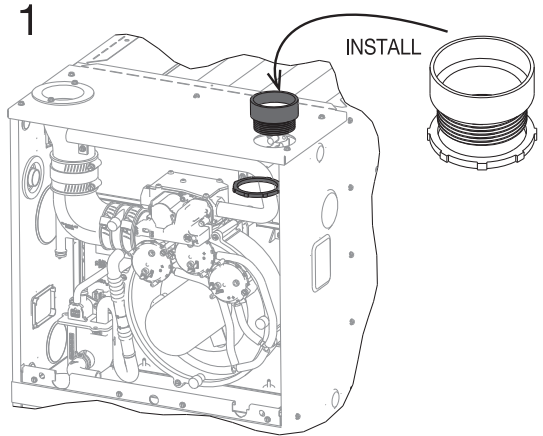
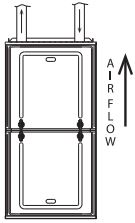

INSTALL INTAKE COUPLING IN TOP PLATE

NOTE: THESE CONVERSION INSTRUCTIONS ARE INTENTIONALLY GENERIC, SOME PARTS MAY BE DIFFERENT IN YOUR FURNACE

2

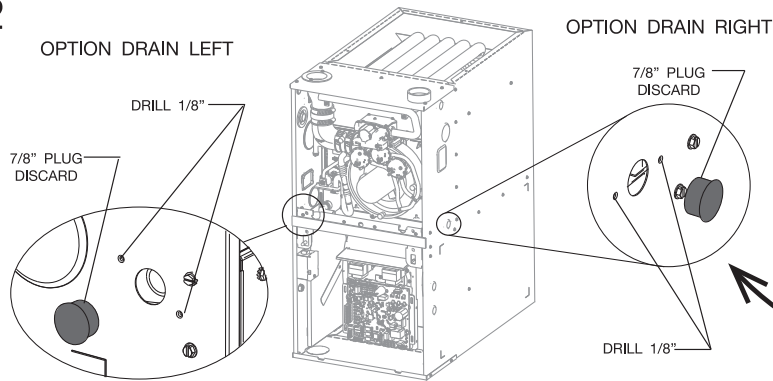

DETERMINE RIGHT OR LEFT DRAIN OPTION.  
LOCATE 7/8" HOLE IN JACKET SIDE.  
REMOVE PLUG - DISCARD  
DRILL (2) Ø 1/8" HOLES FOR THE BULKHEAD COUPLING.

3

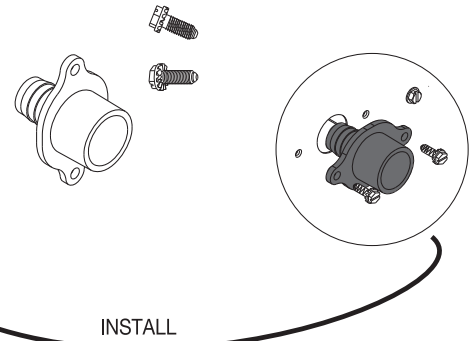

INSTALL

INSTALL BULKHEAD COUPLING USING (2) SCREWS.  
INSTALL IN JACKET WITH THE BARBED FITTING POINTED INTO THE VESTIBULE.

4A

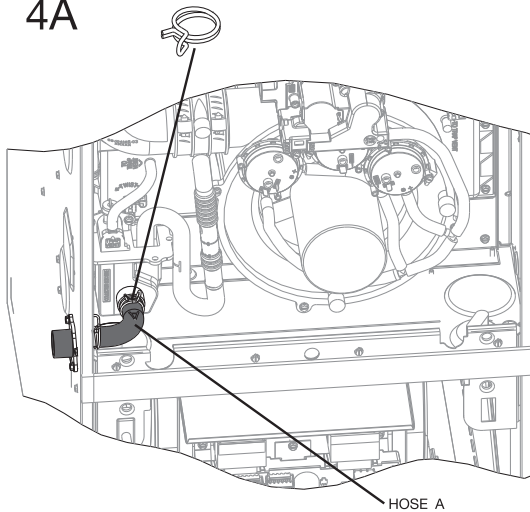

4a - LEFT SIDE DRAIN OPTION

ATTACH HOSE A (PRE-INSTALLED) TO BULKHEAD COUPLING.  
INSTALL HOSE CLAMP ON HOSE OVER BULK HEAD COUPLING.

4B

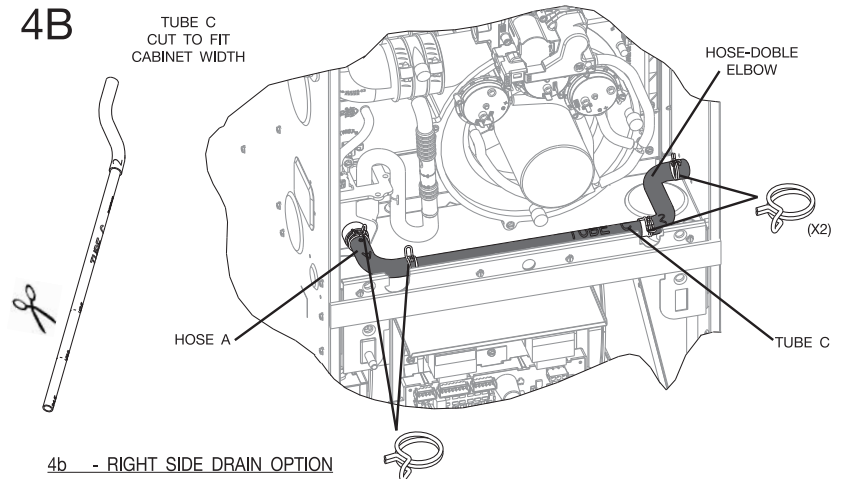

4b - RIGHT SIDE DRAIN OPTION

4b1 - CUT TUBE "C" TO FIT CORRESPONDING CABINET WIDTH.  
4b2 - INSERT TUBE "C" INTO END "2" OF HOSE - DOUBLE ELBOW  
4b3 - SLIDE TWO WIRE CLAMPS OVER TUBE "C", SLIDE ONE WIRE CLAMP OVER END "1" OF HOSE - DOUBLE ELBOW.  
4b4 - INSTALL TUBE "C" WITH HOSE CLAMP AS SHOWN TO HOSE "A" "PRE ASSEMBLED".  
4b5 - ATTACH HOSE - DOUBLE ELBOW TO BULKHEAD COUPLING POSITION WIRE HOSE CLAMP.

NOTE: PLIERS NECESSARY TO ADD OR REMOVE CLAMPS

ST-A1194-68-00

## Checklist:

- VERIFY ALL HOSES ARE SECURE AND FULLY SEATED.
- CONFIRM THAT ALL HOSES ARE FREE OF KINKS.
- CONFIRM ALL HOSES AND OTHER DRAIN PARTS HAVE A SLOPE IN DIRECTION OF WATER FLOW
- BOTH WORM DRIVES ON THE HOSE CLAMPS OF THE IDB COUPLING MUST BE LOCATED ON THE TOP OF THE COUPLING. SEE LOCATION DETAIL IN THE GENERAL CONVERSION INSTRUCTIONS AT THE BEGINNING OF THIS SECTION.
- ALL CLAMPS AND COUPLINGS ARE TIGHTENED
- ALL DRAIN PORTS ARE PLUGGED
- UNIT HAS FORWARD PITCH
- HEAT TAPE INSTALLED (IF REQUIRED)

---

## Notes:



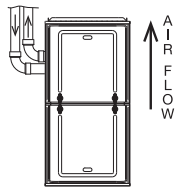

# UPFLOW LEFT VENT

## PARTS NEEDED:

FROM PARTS BAG (PROVIDED W/UNIT)

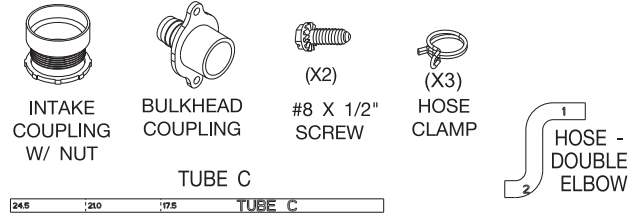

FROM CONVERSION KIT RXGY-CK

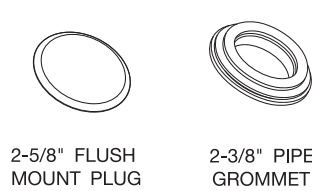

**!** PARTS NEEDED FOR THIS CONVERSION REQUIRE THE OUTLINED ITEMS FROM THE PARTS BAG AND CONVERSION KIT RXGY-CK. YOU MUST HAVE THESE PARTS BEFORE PROCEEDING.

## TOOLS/MATERIALS NEEDED:

- DRILL
- PLIERS
- 5/16 HEX HEAD DRIVER
- TUBING CUTTER
- 1/8" DRILL BIT
- FLAT HEAD SCREWDRIVER
- 1/4" HEX HEAD DRIVER

NOTE: THESE CONVERSION INSTRUCTIONS ARE INTENTIONALLY GENERIC, SOME PARTS MAY BE DIFFERENT IN YOUR FURNACE

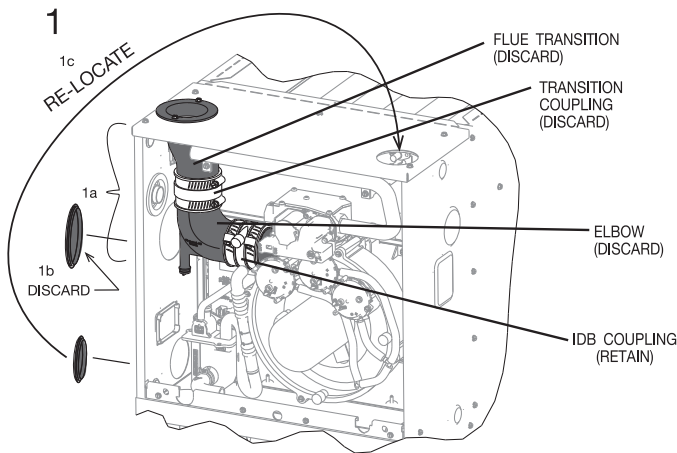

- 1a - REMOVE FLUE TRANSITION, TRANSITION COUPLING, AND ELBOW. (NOTE: REMOVE INDUCER COUPLING W/ELBOW FOR EASIER REMOVAL).
- 1b - REMOVE 3-3/8" FLUSH MOUNT PLUG FROM JACKET - DISCARD.
- 1c - RELOCATE 2-3/8" FLUSH MOUNT PLUG FROM JACKET TO TOP PLATE.

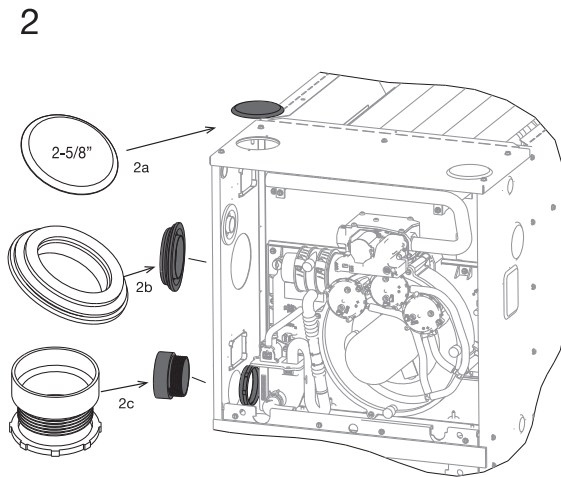

- 2a - INSTALL 2-5/8" FLUSH MOUNT PLUG IN TOP PLATE.
- 2b - INSTALL 2" PIPE GROMMET AS SHOWN.
- 2c - INSTALL INTAKE COUPLING AS SHOWN.

NOTE:  
IF THE IDB COUPLING IS REMOVED, IT MUST BE REPLACED IN THE PROPER ORIENTATION. AN ARROW IS PRESENT ON THE COUPLING TO INDICATE THE DIRECTION OF EXHAUST FLOW. MAKE SURE THE ARROW POINTS IN THE CORRECT DIRECTION.

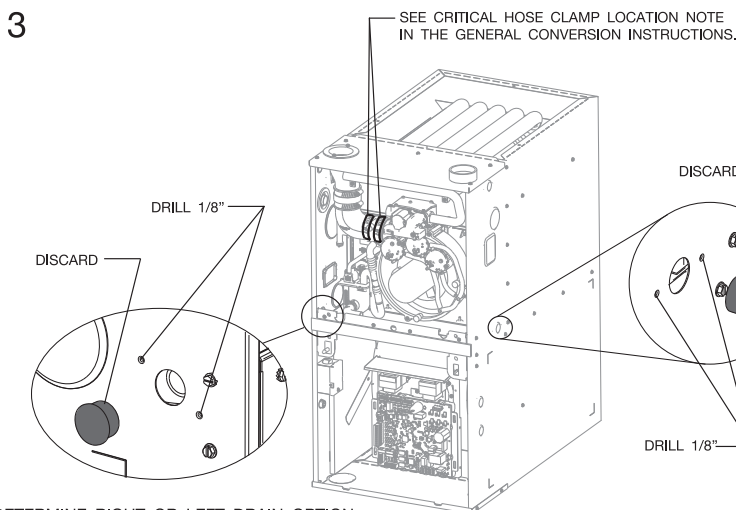

- DETERMINE RIGHT OR LEFT DRAIN OPTION.
- LOCATE 7/8" HOLE IN JACKET SIDE.
- REMOVE PLUG - DISCARD
- DRILL (2) Ø 1/8" HOLES FOR THE BULKHEAD COUPLING.

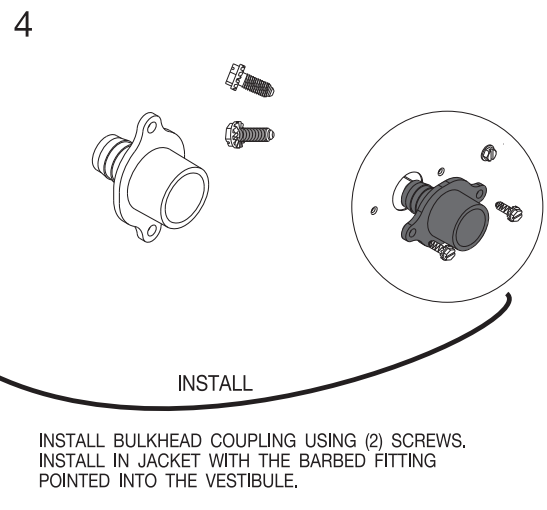

INSTALL BULKHEAD COUPLING USING (2) SCREWS. INSTALL IN JACKET WITH THE BARBED FITTING POINTED INTO THE VESTIBULE.

5A

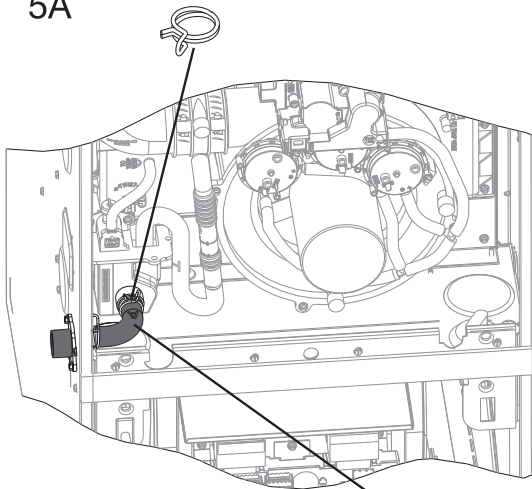

5a - LEFT SIDE DRAIN OPTION

ATTACH HOSE A (PRE-INSTALLED) TO BULKHEAD COUPLING. INSTALL HOSE CLAMP ON HOSE OVER BULK HEAD COUPLING.

5B

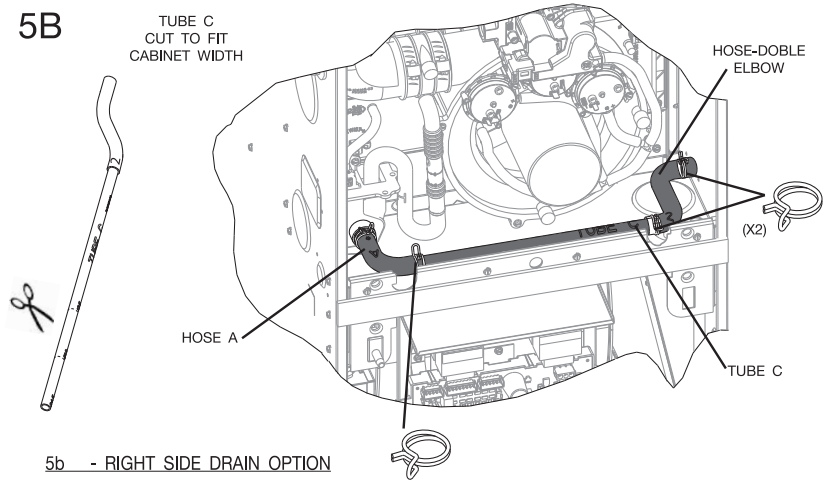

5b - RIGHT SIDE DRAIN OPTION

- 5b1 - CUT TUBE "C" TO FIT CORRESPONDING CABINET WIDTH.
- 5b2 - INSERT TUBE "C" INTO END "2" OF HOSE- DOUBLE ELBOW
- 5b3 - SLIDE TWO WIRE CLAMPS OVER TUBE "C", SLIDE ONE WIRE CLAMP OVER END "1" OF HOSE - DOUBLE ELBOW.
- 5b4 - INSTALL TUBE "C" WITH HOSE CLAMP AS SHOWN TO HOSE "A" "PRE ASSEMBLED".
- 5b5 - ATTACH HOSE - DOUBLE ELBOW TO BULKHEAD COUPLING POSITION WIRE HOSE CLAMP.

**NOTE: PLIERS NECESSARY TO ADD OR REMOVE CLAMPS**

## Checklist:

- \_\_\_ VERIFY ALL HOSES ARE SECURE AND FULLY SEATED.
- \_\_\_ CONFIRM THAT ALL HOSES ARE FREE OF KINKS.
- \_\_\_ CONFIRM ALL HOSES AND OTHER DRAIN PARTS HAVE A SLOPE IN DIRECTION OF WATER FLOW
- \_\_\_ BOTH WORM DRIVES ON THE HOSE CLAMPS OF THE IDB COUPLING MUST BE LOCATED ON THE TOP OF THE COUPLING. SEE LOCATION DETAIL IN THE GENERAL CONVERSION INSTRUCTIONS AT THE BEGINNING OF THIS SECTION.
- \_\_\_ ALL CLAMPS AND COUPLINGS ARE TIGHTENED
- \_\_\_ ALL DRAIN PORTS ARE PLUGGED
- \_\_\_ UNIT HAS FORWARD PITCH
- \_\_\_ HEAT TAPE INSTALLED (IF REQUIRED)

## Notes:

External filter racks are available from the distributor. Use the following part numbers when ordering:

RXGF-CA	External Side Filter Rack Kit		
RXGF-F17	17.5"	15.0"	16.0" X 25.0"
RXGF-F21	21.0"	18.5"	20.0" X 25.0"
RXGF-F24	24.5"	22.0"	20.0" X 25.0"

Proper air flow is required for the correct operation of this furnace. Restricted air flow can cause erratic operation and can damage the heat exchanger. The duct system must carry the correct amount of air for heating and cooling if summer air conditioning is used.

## **▲ WARNING**

**ZONING SYSTEMS ARE NOT DIRECTLY SUPPORTED IN THIS MANUAL. IF A THIRD PARTY SYSTEM IS USED REFER TO THE MANUFACTURER OF THAT PRODUCT FOR INSTALLATION AND OPERATION INSTRUCTIONS.**

**ZONING SYSTEMS USED ON THIS PRODUCT MUST HAVE SENSORS TO PREVENT FURNACES AND/OR HEATING ELEMENTS FROM CYCLING ON INTERNAL LIMIT CONTROLS. THE ZONING SYSTEM MUST NOT ALLOW THE EVAPORATOR COILS AND/OR HYDRONIC COILS FROM FREEZING.**

## **▲ WARNING**

**SOME HEATING AIRFLOW VALUES MAY BE HIGHER THAN THOSE REQUIRED FOR COOLING. BE SURE TO SIZE DUCT FOR THE MAXIMUM POSSIBLE AIRFLOW VALUE.**

**SIZE AIRFLOW DISTRIBUTION SYSTEM TO ACCEPTABLE INDUSTRY STANDARDS AND METHODS. TOTAL STATIC PRESSURE DROP OF THE AIR DISTRIBUTION SYSTEM SHOULD NOT EXCEED 1.0 INCHES W.C. THIS WILL INCLUDE ANY AIR CONDITIONER COIL, AIR FILTRATION SYSTEM, ZONING SYSTEM, DUCTWORK, ETC. REFER TO ADDED EQUIPMENT TECHNICAL INFORMATION TO OBTAIN PRESSURE DROP INFORMATION WHEN EQUIPMENT IS OPERATING AT RECOMMENDED HEATING OR COOLING CFMS.**

**IMPORTANT:** When using outside air, design and adjust the system to maintain a return air temperature ABOVE 55° F during the heating season.

**NOTE:** Return air grilles and warm air registers must not be obstructed or closed.

**NOTE:** Both flanges on the supply and return openings must be bent either up or down but cannot remain flat as shipped from the factory. See Figure 8 for details.

## **▲ WARNING**

**THE SOLID METAL BASE PAN MUST BE REMOVED FROM THE TOP OF THE FURNACE BEFORE INSTALLING THE FURNACE. FAILURE TO REMOVE THIS PAN FROM THE SHIPPING POSITION CAN RESULT TO DAMAGE TO THE FURNACE OR EQUIPMENT.**

**FIGURE 6**

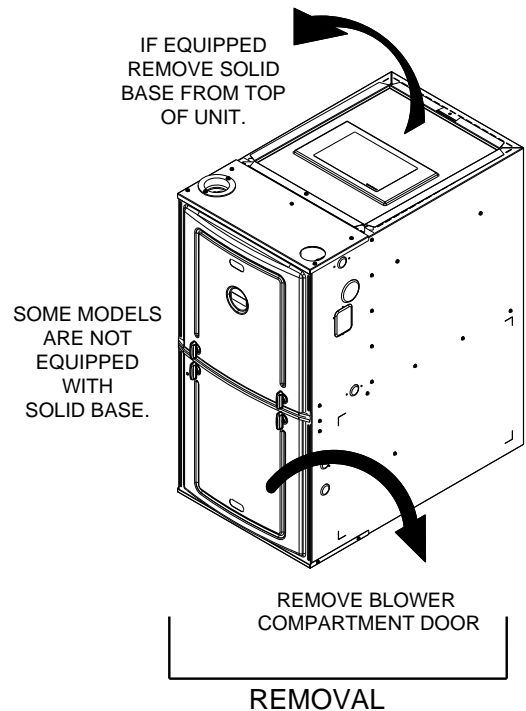

ST-A1194-49

## **▲ WARNING**

**BLOWER AND BURNERS MUST NEVER BE OPERATED WITHOUT THE BLOWER DOOR IN PLACE. THIS IS TO PREVENT DRAWING GAS FUMES (WHICH COULD CONTAIN HAZARDOUS CARBON MONOXIDE) INTO THE HOME THAT COULD RESULT IN PERSONAL INJURY OR DEATH.**

## UPFLOW INSTALLATIONS

1. Position the unit to minimize long runs of duct or runs of duct with many turns and elbows.
2. For side return: Cut an opening in the side. The opening should be cut the full width and height of the knockouts on the unit. See Figure 9.
3. If summer air conditioning is desired, position the indoor coil on the supply-air side of the unit. Ensure that no air can bypass the coil.
4. Connect the furnace to the supply air plenum.
5. Connect the return air ducting to the return-air opening at the bottom and/or side of the unit. Make the connections air-tight to prevent the migration of toxic fumes and odors including carbon monoxide from migrating into the living space.

# DUCTING

- If a filter is installed near the furnace, be sure to have adequate space for installation and removal of the unit filter.
- NOTE:** Where the maximum airflow is 1800 CFM or more, and multiple return air plenums are required for installation; the bottom and/or **BOTH** sides may be used for the return air, however the rear of the furnace can **NOT** be used as a return air in any configuration.

**NOTE:** DO NOT take return air from furnace rooms, garages or cold areas. Avoid return air from utility rooms, kitchens, laundry rooms and bathrooms.

## WARNING

**UPFLOW FURNACE: THE SOLID METAL BASE PLATE (SHIPPED WITH THE FURNACE) MUST BE INSTALLED IN THE FURNACE BOTTOM WHEN USING SIDE AIR RETURN. FAILURE TO INSTALL A BASE PLATE COULD CAUSE THE PRODUCTS OF COMBUSTION TO CIRCULATE INTO THE LIVING SPACE AND CREATE POTENTIALLY HAZARDOUS CONDITIONS, INCLUDING CARBON MONOXIDE POISONING OR DEATH. FOR BOTTOM RETURN, A SOLID METAL BASE PAN MUST NOT BE INSTALLED.**

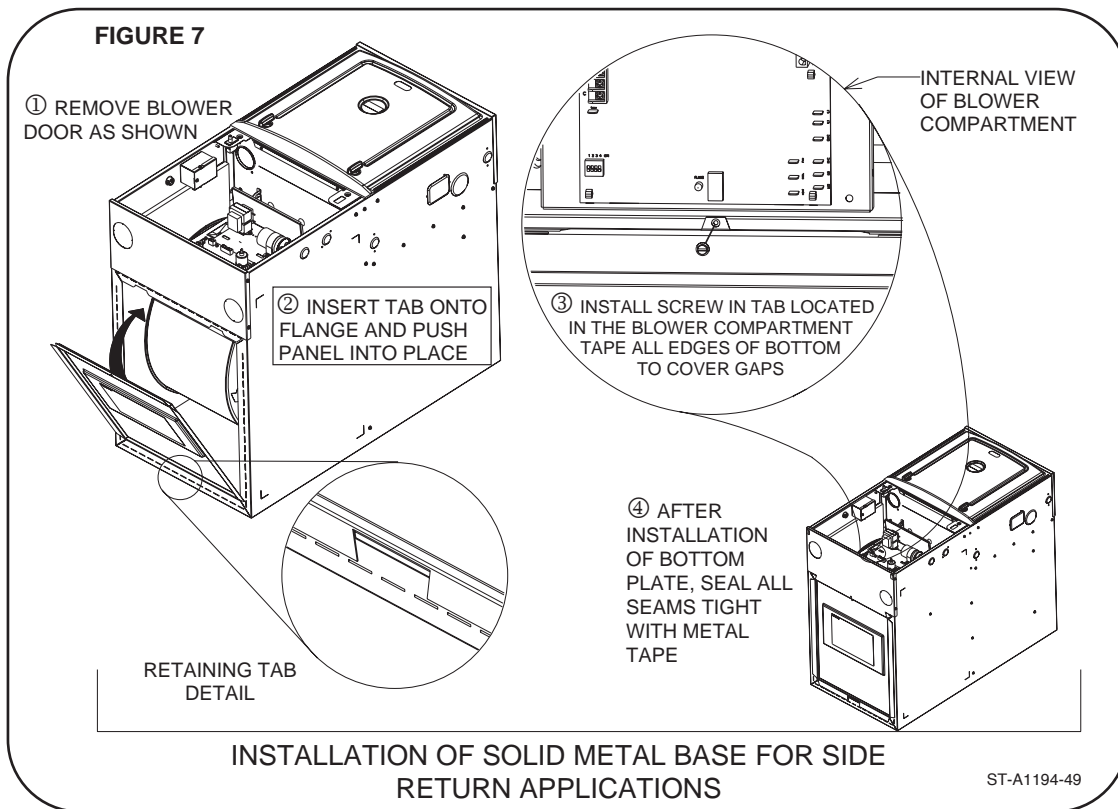
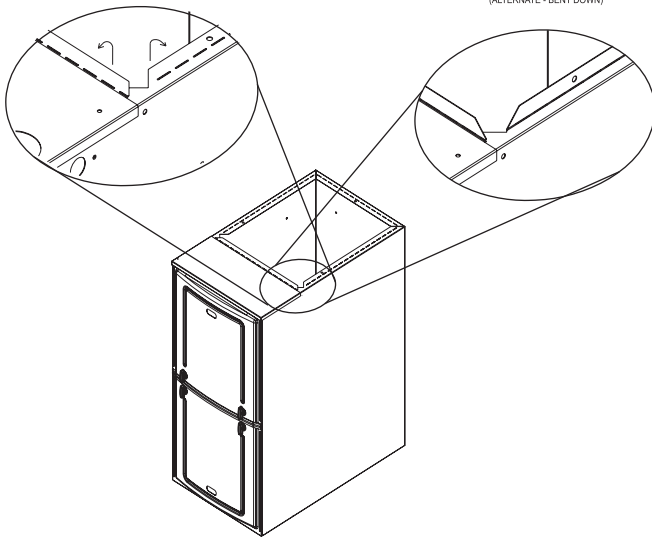

FIGURE 8

## FLANGE BENDING INSTRUCTIONS

AS - SHIPPED FLAT

INSTALLER BENT - UP  
(ALTERNATE - BENT DOWN)



**NOTES:**

THIS VIEW IS REPRESENTATIVE OF BOTH SUPPLY AND RETURN OPENINGS.

DUCT FLANGES MUST BE FIELD-BENT ALONG PERFORATIONS EITHER INTO OR OUT OF THE FURNACE AS NECESSARY FOR INSTALLATIONS BUT **NEITHER FLANGE CAN REMAIN FLAT.**

INSTALLER SHOULD USE DUCK BILLED PLIERS (AKA FOLDING PLIERS) TO BEND THE FLANGE ALONG THE PERFORATIONS.

ST-A1194-39-00

FIGURE 9

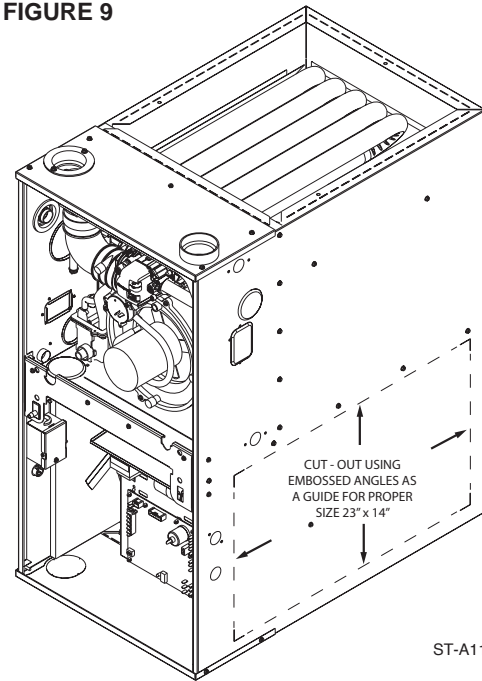

ST-A1194-04-X0

# AIRFLOW SUMMARY

Model Input (Btu)		60k 17"	70k 17"	85k 21"	100k 21"	115k 24"
Nominal Cabinet Size (in)						
<b>Comfort Select - CFM Options (Factory Settings)</b>						
HEATING CFM [L/s]	LOW HEAT (40%)	494 [233]	538 [254]	655 [309]	659 [311]	897 [424]
	MEDIUM HEAT (65%)	632 [298]	713 [337]	848 [400]	977 [461]	1117 [527]
	HIGH HEAT (100%)	825 [389]	959 [453]	1119 [528]	1422 [671]	1425 [673]
<b>Efficiency Select - CFM Options (Factory Settings)</b>						
HEATING CFM [L/s]	LOW HEAT (40%)	550 [260]	599 [283]	730 [345]	725 [342]	1000 [472]
	MEDIUM HEAT (65%)	690 [325]	778 [367]	926 [437]	1058 [499]	1271 [600]
	HIGH HEAT (100%)	885 [418]	1029 [486]	1200 [566]	1525 [720]	1520 [717]

\*S= Standard Models

NOTES Standard model complies with Californian low NOx requirements.

Refer to Installation Manual for complete heating dip switch options.

Model Input (Btu)			60k 17"	70k 17"	85k 21"	100k 21"	115k 24"
Nominal Cabinet Size (in)							
TARGET COOLING/ HEAT PUMP AIRFLOW	HIGH COOLING CFM [L/s]	SW 4 = OFF SW 5 = OFF	1050 [496]	1050 [496]	1750 [825]	1750 [825]	1750 [825]
		SW 4 = ON SW 5 = OFF	875 [413]	875 [413]	1400 [661]	1400 [661]	1400 [661]
		SW 4 = OFF SW 5 = ON	700 [330]	700 [330]	1225 [578]	1225 [578]	1225 [578]
		SW 4 = ON SW 5 = ON	525 [248]	525 [248]	1050 [496]	1050 [496]	1050 [496]
	LOW COOLING CFM [L/s]	SW 4 = OFF SW 5 = OFF	788 [372]	788 [372]	1313 [619]	1313 [619]	1313 [619]
		SW 4 = ON SW 5 = OFF	656 [248]	656 [310]	1050 [496]	1050 [496]	1050 [496]
		SW 4 = OFF SW 5 = ON	525 [248]	525 [248]	919 [434]	919 [434]	919 [434]
		SW 4 = ON SW 5 = ON	394 [185]	394 [185]	788 [372]	788 [372]	788 [372]

[ ] Designates Metric Conversions

# GENERAL VENTING REQUIREMENTS AND GUIDELINES

## VENTING & COMBUSTION AIR REQUIREMENTS

### WARNING

**READ AND FOLLOW ALL INSTRUCTIONS IN THIS SECTION. FAILURE TO PROPERLY VENT THIS FURNACE CAN CAUSE CARBON MONOXIDE POISONING, OR AN EXPLOSION OR FIRE, RESULTING IN PROPERTY DAMAGE, PERSONAL INJURY OR DEATH.**

### WARNING

**THIS FURNACE AND ANY OTHER FUEL-BURNING APPLIANCE MUST BE PROVIDED WITH ENOUGH FRESH AIR FOR PROPER COMBUSTION AND VENTILATION OF THE FLUE GASES. MOST BUILDINGS WILL REQUIRE THAT OUTSIDE AIR BE SUPPLIED INTO THE FURNACE AREA. FAILURE TO DO SO CAN CAUSE PERSONAL INJURY OR DEATH FROM CARBON MONOXIDE POISONING. REFER TO SECTION TITLED “NON-DIRECT VENTING” TO DETERMINE IF THE FURNACE MUST USE OUTSIDE AIR FOR COMBUSTION.**

This furnace removes both sensible and latent heat from the combustion gases. Removal of latent heat results in the condensation of flue gas water vapor. This condensed water vapor drains from the secondary heat exchanger and out of the unit into the drain trap.

When installed as a non-direct vent furnace, only exhaust piping is required and inside combustion air may be used. Refer to the section on “NON-DIRECT VENTING.”

Direct vent installations require a dedicated combustion air and venting system. All air for combustion is taken from the outside atmosphere and all combustion products are discharged to the outdoors.

Adequate facilities for providing air for combustion and ventilation must be provided in accordance with Section 5.3, “Air for Combustion and Ventilation” of the National Fuel Gas Code, ANSI Z223.1 (latest edition), in Canada CSA B149.1; Canadian Natural Gas and Propane Installation Code and The National Fire Code of Canada, or applicable provisions for the local building codes, and not obstructed so as to prevent the flow of air to the furnace.

**IMPORTANT:** Air for combustion and ventilation must not come from a corrosive atmosphere. Any failure due to corrosive elements in the atmosphere is excluded from the warranty coverage.

Combustion air must be free of acid-forming chemicals such as sulfur, fluorine and chlorine. These elements are found in aerosol sprays, detergents, bleaches, cleaning solvents, air fresheners, paint and varnish removers, refrigerants and many other commercial and household products. When burned in a gas flame, vapors from these products form acid compounds. The acid compounds increase the dew point temperature of the flue products and are highly corrosive after they condense.

The following types of installations (but not limited to the following) may require outdoor air for combustion (direct vent) due to chemical exposures:

- Commercial buildings
- Buildings with indoor pools
- Furnaces installed in laundry rooms
- Furnaces in hobby or craft rooms
- Furnaces installed near chemical storage areas

If combustion air is exposed to the following substances (but not limited to the following), it should not be used and the furnace may require outdoor air for combustion (direct vent).

- Permanent wave solutions
- Chlorinated waxes and cleaners
- Chlorine-based swimming pool chemicals
- Water softening chemicals
- De-icing salts or chemicals
- Carbon tetrachloride
- Halogen type refrigerants
- Printing inks, paint removers, varnishes etc.
- Cleaning solvents (such as perchloroethylene)
- Hydrochloric acid
- Cements and glues
- Antistatic fabric softeners for clothes dryers
- Masonry curing and acid washing materials

### WARNING

**ALL FURNACE INSTALLATIONS MUST COMPLY WITH THE NATIONAL FUEL GAS CODE, IN CANADA CSA B149.1; CANADIAN NATURAL GAS AND PROPANE INSTALLATION CODE AND THE NATIONAL FIRE CODE OF CANADA, NFPA 54 AND LOCAL CODES TO PROVIDE ADEQUATE COMBUSTION AND VENTILATION AIR FOR THE FURNACE. FAILURE TO DO SO CAN RESULT IN EXPLOSION, FIRE, PROPERTY DAMAGE, CARBON MONOXIDE POISONING, PERSONAL INJURY OR DEATH.**

Combustion air requirements are determined by whether the furnace is in an open (unconfined) area or in a confined space such as a closet or small room.

When the furnace is installed in the same space with other gas appliances, such as a water heater, be sure there is an adequate supply of combustion and ventilation air for the furnace and the other appliances. Do not delete or reduce the combustion air supply required by the other gas appliances in this space. See Z223.1, National Fuel Gas Code (NFPA 54), in Canada CSA B149.1; Canadian Natural Gas and Propane Installation Code and The National Fire Code of Canada, for determining the combustion air requirements for gas appliances. An unconfined space must have at least 50 cubic feet (volume) for each 1,000 BTUH of the total input of all appliances in the space. If the open space containing the appliances is in a building with tight construction (contemporary construction), outside air may still be required for the appliances to burn and vent properly. Outside air openings should be sized the same as for a confined space.

# GENERAL VENTING REQUIREMENTS AND GUIDELINES

## VENTING & COMBUSTION AIR REQUIREMENTS (cont.)

**IMPORTANT: ONLY THE CURRENT VENT INSTRUCTIONS APPLY.** All 90 Plus Gas Furnaces cannot be common-vented.

### OVERTEMPERATURE SAFETY SWITCHES

Furnaces are equipped with safety switches in the burner compartment to protect against over-temperature conditions caused by inadequate combustion air supply. The switches are located in the burner compartment. If a switch is tripped it must be manually reset after clearing the fault condition which caused it to open.

#### WARNING

**DO NOT BYPASS, JUMPER, OR REMOVE ANY SAFETY SWITCH FROM THE FURNACE CONTROL CIRCUIT. IF A SAFETY SWITCH CAUSES THE FURNACE TO SHUT DOWN OR OPERATE INTERMITTENTLY, IT IS AN INDICATION OF A POTENTIAL SAFETY HAZARD THAT MUST BE ADDRESSED BY A QUALIFIED TECHNICIAN, SERVICE AGENCY OR THE GAS SUPPLIER. DO NOT RESET SAFETY CONTROLS WITHOUT CORRECTIVE ACTION AND/OR VERIFICATION OF PROPER SAFE OPERATION BY A QUALIFIED INSTALLER, SERVICE AGENCY OR THE GAS SUPPLIER.**

**REPLACE ANY SAFETY CONTROL COMPONENT ONLY WITH IDENTICAL OEM REPLACEMENT PARTS.**

#### WARNING

**IN CANADA, PRODUCTS CERTIFIED FOR INSTALLATION AND INTENDED TO BE VENTED WITH PLASTIC VENT SYSTEMS (PVC, CVPC & POLYPROPYLENE) MUST USE VENT SYSTEMS THAT ARE CERTIFIED TO THE STANDARD FOR TYPE BH GAS VENTING SYSTEMS, ULC S636.**

**THE COMPONENTS OF THE CERTIFIED MATERIAL MUST NOT BE INTERCHANGED WITH OTHER VENT SYSTEMS OR UNLISTED PIPE/FITTINGS.**

**PLASTIC COMPONENTS AND SPECIFIED PRIMERS AND GLUES OF THE CERTIFIED SYSTEM MUST BE FROM A SINGLE SYSTEM MANUFACTURER AND NOT INTERMIXED WITH OTHER SYSTEM MANUFACTURER'S PARTS.**

**VENT TERMINATIONS ARE NOT REQUIRED TO BE FROM THE SAME MANUFACTURER AS THE REST OF THE VENTING BUT VENT TERMINATIONS MUST BE ULC S636 APPROVED.**

**NOTE: WITH THE EXCEPTION OF THE TERMINATION INLET AIR PIPING IS NOT CONSIDERED TO BE A PART OF THE "VENTING SYSTEM". THE REQUIREMENT THAT VENT MATERIAL BE CERTIFIED TO ULC S636 DOES NOT APPLY TO INLET AIR PIPING.**

**REGARDLESS, ALL TERMINATIONS ON BOTH INLET AND OUTLET PIPES MUST BE CONSTRUCTED FROM COMPONENTS BUILT TO ULC-S636 REQUIREMENTS.**

## MATERIAL REQUIREMENTS PIPING REQUIREMENTS

Vent materials can be of a plastic type if they provide the proper temperature and corrosive resistance pvc schedule 40 pipe per ASTM D1785 and fitting sized per D2466. Other plastics can be used per UL-1738c.

**NOTE:** Cellular core PVC is NOT approved for use. Each run of venting must be made by the same material and manufacturer. Joints must be made per the manufacturer's specified method. Do not use cements and adhesives not approved for your application.

**NOTE:** Material, primer, solvent-cement certified to UL 1738 is also approved for use. The material products must be the same dimensionally as material described in this section, and installed in accordance with the manufacturer's specific venting and combustion air requirements listed in the section, to ensure the system is installed per UL 1738 certification and other applicable standards.

1. All horizontal piping must slope upward from the furnace with a minimum slope of ¼ inch per foot of horizontal vent so that condensate drains back toward the furnace.
2. All horizontal runs must be supported at least every 4 feet. No sags or dips are permitted.
3. **IMPORTANT:** Do not common vent with any other appliance. Do not install in the same chase or chimney with a metal or high temperature plastic pipe from another gas or fuel-burning appliance unless the required minimum clearances to combustibles are maintained between the plastic pipe and other pipes. For Canada PVC, CPVC and polypropylene can be used as long as they conform with ULCS-636C requirements.
4. All vent installed through unconditioned spaces where below-freezing temperatures are expected must be insulated with an approved insulating material. Materials such as Armaflex or Rubatex insulation may also be used as long as there is no heat tape applied to the vent pipe. For horizontal runs where water may collect, wrap the vent pipe with self-regulating 3 watt or 6 watt heat tape. The heat tape must be U.L. listed and installed per the manufacturer's instructions.  
**NOTE:** Never cover heat tape with insulation.
5. The minimum vent pipe length is 5 feet [1.5m].
6. **IMPORTANT:** No part of the combustion air and/or



# GENERAL VENTING REQUIREMENTS AND GUIDELINES

## VENTING & COMBUSTION AIR REQUIREMENTS (cont.)

vent pipes may be installed underground.

7. Piping at a roof, wall or other penetration must be immobilized to prevent pipes from disconnecting. Disconnected pipes may allow flue products to be released inside the structure.
8. For Direct Vent systems, all pipe penetrations through roof or sidewall must be installed so that the vent and combustion air intake pipes terminate in the same atmospheric pressure zone.
9. Vent terminations must be installed with the minimum clearances specified in the TERMINATION REQUIREMENTS sections of this manual and **Figure 15** (for Non-Direct Vent) and **Figures 16, 17 & 26** (for direct Vent installations).
10. Piping external to the structure (excluding approved venting terminations) and vent passing through unheated crawl-spaces, attics, verandas, patios or decks must be insulated with approved insulating material to prevent freezing as required for local climate.

### WARNING

**PVC/CPVC SOLVENT CEMENTS AND PRIMERS ARE HIGHLY FLAMMABLE. PROVIDE ADEQUATE VENTILATION AND DO NOT ASSEMBLE NEAR A HEAT SOURCE OR AN OPEN FLAME. DO NOT SMOKE. AVOID SKIN OR EYE CONTACT. OBSERVE ALL CAUTIONS AND WARNINGS PRINTED ON MATERIAL CONTAINERS. FAILURE TO FOLLOW THESE GUIDELINES MAY RESULT IN FIRE, EXPLOSION OR ASPHYXIATION CAUSING PERSONAL INJURY OR DEATH.**

**TABLE 1: APPLICABLE ASTM STANDARDS FOR VENT MATERIALS (U.S. Only)**

Materials	Sch. 40 Pipe	SDR Pipe	Cell Core Pipe	Fittings	Primer	Solv. Cement
ABS	D1527	-	F628	D2468 & D2661	-	D2235
PVC	D1785	D2241	F891	D2466 & D2665	F656	D2564
CPVC	F441	F442	-	F348	-	F493
ABS to PVC	-	-	-	-	-	D3138

For Canadian installations all exhaust venting materials must be certified to ULCS-636C.

### JOINING PIPE AND FITTINGS

All pipe, fittings, solvent cement, primers and procedures must be installed following the vent manufacturer's installation instructions and must conform to American National Standards Institute and American Society for Testing Materials (ANSI/ASTM) standards as shown in the **Table 1** below:

### CEMENTING JOINTS

Properly seal all joints in the PVC vent using the following materials and procedures.

### PVC CLEANER-PRIMER AND PVC MEDIUM-BODY SOLVENT CEMENT

**IMPORTANT:** After cutting pipe, remove all ragged edges and burrs. This is important to prevent reduction in pressure drop throughout the system.

1. Cut pipe end square. Chamfer edge of pipe. Clean fitting socket and pipe joint area of all dirt, grease and moisture.
2. After checking pipe and socket for proper fit, wipe socket and pipe with cleaner-primer. Apply a liberal coat of primer to inside surface of socket and outside of pipe. Read instructions included with the primer for proper application.
3. Apply a thin coat of cement evenly within the socket. Quickly apply a heavy coat of cement to the pipe end and insert pipe into the fitting with a slight twisting movement until it bottoms out.

**NOTE:** Cement must be fluid. If not, re-coat.

4. Hold the pipe in the fitting for 30 seconds to prevent the tapered socket from pushing the pipe out of the fitting.
5. Wipe all excess cement from the joint with a rag. Allow 15 minutes before handling. Cure time varies according to fit, temperature and humidity.

**NOTE:** Stir the solvent cement frequently while using. Use a natural bristle brush or the dauber supplied with the can. The proper brush size is one inch.

**IMPORTANT:** For proper installation:

**DO NOT** use solvent cement that has become curdled, lumpy or thickened.

**DO NOT** thin. Observe shelf precautions printed on containers. For applications below 32°F, use only low-temperature type solvent cement.

# GENERAL VENTING REQUIREMENTS AND GUIDELINES

## VENT PIPE SIZING AND MAXIMUM VENT LENGTHS

### EQUIVALENT VENT LENGTHS

The concept of equivalent vent lengths is frequently used in piping systems to account for pressure drop of fittings, such as elbows. The equivalent length of a fitting is the length of a straight section of pipe that has an equivalent pressure drop in the application as the fitting used. With the equivalent length vent concept, a vent system can use up to the maximum number of elbows and vent length of straight pipe as long as the maximum equivalent vent length is not exceeded.

There are several different types of elbows that can be used when constructing a vent system. **Figure 10** shows the standard dimensions for standard and long-sweep 90° (¼ turn) elbows as specified by ASTM 3311, Standard Specification for Drain, Waste and Vent (DWV) Plastic Fittings Patterns.

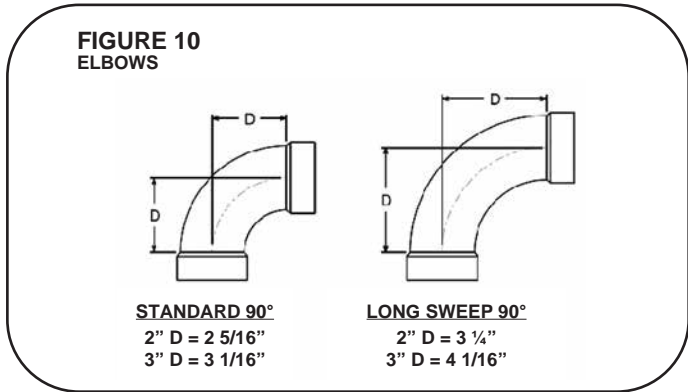

A long-sweep (AKA Long-Radius) 90° (¼ turn) elbow has an equivalent vent length of 5 feet of straight pipe for either 2 inch or 3 inch plastic pipe. A standard 90° elbow has an equivalent vent length of 10 feet of straight pipe. This equivalent length can be used in circumstances where it might be necessary to lengthen the vent at the outside of the structure, such as in areas with large accumulations of snow in winter. **Table 2** shows the equivalent lengths of different types of elbows.

Fitting Type	Equivalent Length
90° Standard Elbow	10 Feet of Pipe
45° Long-Sweep Elbow	2-1/2 Feet of Pipe
90° Long-Sweep Elbow	5 Feet of Pipe

**Table 3** specifies the equivalent maximum vent lengths specified by the manufacturer for each furnace. Listed table maximums have been qualified by the manufacturer. Dependant on individual installation specifics, installations beyond the table recommendations may cause erratic pressure switch operation.

**Examples:**

1. A 60KBTU direct-vent installation needs a 31 foot long vent run with qty=5, 90° long-sweep elbows and 2 inch pipe.

31 feet of 2 inch pipe =	31 equivalent feet
Qty = 5, 90° long-sweep elbows =	25 equivalent feet
<hr/>	
Total =	56 equivalent feet

Since the maximum equivalent vent length specified for a 60KBTU furnace is 65 feet, this installation is acceptable.

2. If the installation from Example 1 were installed with standard elbows instead of long-sweep elbows, the calculation would be as follows:

31 feet of 2 inch pipe =	31 equivalent feet
Qty = 5, 90° standard elbows =	50 equivalent feet
<hr/>	
Total =	81 equivalent feet

This installation is NOT acceptable as it exceeds the 65 foot maximum specified for this model.

# GENERAL VENTING REQUIREMENTS AND GUIDELINES

## VENT PIPE SIZING AND MAXIMUM VENT LENGTHS (cont.)

Model Input	Nameplate Input (BTU/H)	Pipe Size	Maximum Equivalent Length (Feet)	Recommended Maximum Number of Elbows*
60k	56,000	2 inchØ	65	6
		3 inchØ	100	6
70k	70,000	2 inchØ	65	6
		3 inchØ	100	6
85k	84,000	2 inchØ	30	2
		3 inchØ	100	6
100k	98,000	2 inchØ	20	2**
		3 inchØ	100	6
115k	112,000	2 inchØ	20	2**
		3 inchØ	100	6
<p><b>NOTE:</b> The elbows needed for the vent termination are not counted in these lengths except at altitudes above 6,000 feet. Above 6,000 feet alternate horizontal vent termination elbows are to be included in the equivalent vent length.</p> <p>* This is the recommended maximum number of long sweep elbows for either 2 or 3 inch pipe. Combinations of long sweep 90s, standard 90s, or 45s may be used, but the manufacturer recommends the use of long sweep 90s whenever possible because the use of the maximum number of standard 90 and 45 elbows only may result in nuisance furnace outages due to individual installation specifics.</p> <p>Exceeding the recommended maximum number of elbows may cause nuisance operation of the pressure switch.</p> <p>** Not applicable for alternate terminations.</p>				

For modulating furnaces, non-direct venting is only authorized for vertical terminations.

**NOTE:** If the vent length exceeds the maximum equivalent length specified for 2" pipe, then the transition from 2" to 3" needs to be within 2 feet of the unit.

# GENERAL VENTING REQUIREMENTS AND GUIDELINES

## VENT PIPE SIZING AND MAXIMUM VENT LENGTHS (cont.)

### POLYPROPYLENE VENT PRODUCTS

Centrotherm brand *Innoflue* and Duravent *Polypro* Single-wall and flex venting products are approved for use on this furnace product only in single appliance applications. Do not exceed maximum venting lengths, diameters or elbows listed in these instructions (**Vent Pipe Sizing and Maximum Vent Lengths** section [Table 3]). Application of these products is limited to the terminations listed in Tables 4 and 5 below. These manufacturers have provisions

for B-vent liners and chimney liners which can be used with this furnace with non-direct venting applications only. Refer to the manufacturer's installation instructions for proper installation. Contact the manufacturer for all installation and application information.

**NOTE:** These venting products are listed for use in Canada under ULC-S636.

**TABLE 4: DURAVENT BRAND POLYPRO & POLYPRO FLEX TERMINATION COMPONENTS**

2" VENT	3" VENT	Description
2PPS-HTP	3PPS-HTP	Horizontal Direct-Vent Termination
2PPS-VK, 2PPS-VK-TC	3PPS-VK, 3PPS-VK-TC	Vertical Concentric Kits
2PPS-HK	3PPS-HK	Horizontal Concentric Kits
2PPS-FK	3PPS-FK	Flex Chimney Lining Kit
2PPS-VFT	3PPS-VFT	Vertical Flex Termination Cap
2PPS-BV4, 2PPS-BV5, 2PPS-BV6	3PPS-BV5, 3PPS-BV6	B-VENT Adapter

**TABLE 5: CENTROTHERM BRAND ECO SYSTEMS TERMINATION COMPONENTS**

2" VENT	3" VENT	Description	Notes
ISCP02	ISCP03	Chimney Cover	For Use on Non-Direct Vent only. <b>DO NOT</b> use with a Direct-Vent Installation.
NA	ISCM03	Stainless Steel Chimney Cover	For Use on Non-Direct Vent only. <b>DO NOT</b> use with a Direct-Vent Installation.
IABC0204 thru IABC0207	IABC0304 thru IABC0307	B-Vent Rain Collar	For Use on on Non-Direct Vent only. <b>DO NOT</b> use with a Direct-Vent Installation.
ISLPT0202	ISLPT0303	Low-Profile Wall Termination	
ISTT0220	ISTT0320	Termination Tee	
ISEP02 & ISEP0239	ISEP03 & ISEP0339	End Pipe	
IFEPO2	NA	2" Flex End Pipe	
NA	ICWT352	Plastic Concentric Wall Termination	Approved for Direct-Vent
ICW2413	ICW3513	Stainless Steel Concentric Wall Termination	Approved for Direct-Vent
ICRT2439	ICRT3539	Concentric Roof (Vertical) Termination	Approved for Direct-Vent

# GENERAL VENTING REQUIREMENTS AND GUIDELINES

## TERMINATION REQUIREMENTS

### ▲ CAUTION

**THE COMBUSTION PRODUCTS AND MOISTURE IN THE FLUE GASES WILL CONDENSE AS THEY LEAVE THE TERMINATION. THE CONDENSATE CAN FREEZE ON THE EXTERIOR WALL, UNDER THE EAVES AND ON SURROUNDING OBJECTS. SOME DISCOLORATION TO THE EXTERIOR OF THE BUILDING IS TO BE EXPECTED. HOWEVER, IMPROPER LOCATION OR INSTALLATION CAN RESULT IN FINISH DAMAGE TO THE BUILDING AND MAY RE-CIRCULATE THE PRODUCTS OF COMBUSTION INTO THE COMBUSTION AIR TERMINAL AND FREEZE.**

Vent terminations for both Non-Direct and Direct-Vent installations must adhere to guidelines specified by the latest edition of ANSI Z21.47 *Gas-Fired Central Furnaces*. These are clearly detailed in **Figure 26** for Direct-Vent installations. In addition to these requirements, the installation and venting must also comply with the National Fuel Gas Code (U.S.) and CSA-B149.1; Canadian Natural Gas and Propane Installation Code (Canada) and the following requirements must also be met:

**NOTE:** Screens of any kind on the inlet or exhaust pipes are not permitted and will void the manufacturer's warranty.

In addition to the requirements shown in **Figure 26** for Direct-Venting, the vent must be installed with the following minimum clearances:

1. The vent terminal shall have a minimum horizontal clearance of 4 feet from electric meters, gas meters, regulators and relief equipment.
2. Locate the furnace combustion air inlet a minimum of 3 feet from the vent of any other gas or fuel-burning ap-

pliance or clothes dryer to prevent recirculation of the flue gases into the furnace combustion air inlet. The only exception to this requirement is the case of multiventing two or more furnaces, which is covered in the section on multiventing of these instructions.

In addition to the minimum clearances listed above and in **Figure 26** (Direct-Vent), the vent location should also be governed by the following guidelines.

1. Avoid terminating under any kind of patio or deck. However, if necessary, vent piping may be installed under a deck as long as the termination(s) is (are) not under the deck.
2. If installing the vent under a deck, insulate it to insure that no condensate freezes and blocks the pipes.
3. Do not terminate in any area or behind any obstruction that may allow the flue products to become stagnant and/or re-circulate.
4. Do not locate on the side of a building with prevailing winter winds. This will help prevent moisture from freezing on the walls and overhangs (under eaves).
5. If extending vent through a brick or masonry surface, a sleeve between the wall and venting is suggested to protect against damage from thermal expansion and contraction.
6. A corrosion-resistant sheet metal or plastic backing plate installed on the wall behind the vent is suggested to prevent exhaust gases and condensate from contacting the wall.
7. Avoid locating too close to shrubs as condensate may stunt growth or kill them.

# GENERAL VENTING REQUIREMENTS AND GUIDELINES

## NON-DIRECT VENT (VERTICAL TERMINATIONS ONLY)

### WARNING

ALL FURNACE INSTALLATIONS MUST COMPLY WITH THE NATIONAL FUEL GAS CODE, NFPA 54, AND IN CANADA CSA B149.1; CANADIAN NATURAL GAS AND PROPANE INSTALLATION CODE, THE NATIONAL FIRE CODE OF CANADA, AND LOCAL CODES TO PROVIDE ADEQUATE COMBUSTION AND VENTILATION AIR FOR THE FURNACE. FAILURE TO DO SO CAN RESULT IN EXPLOSION, FIRE, PROPERTY DAMAGE, CARBON MONOXIDE POISONING, PERSONAL INJURY OR DEATH.

For improved indoor air quality, added safety and product performance we recommend direct vent type installations. If non-direct type vent system is used, the requirements for combustion air must be provided as identified in the National Fuel Gas Code and, in Canada, CSA B149.1; Canadian Natural Gas and Propane Installation Code.

Combustion air requirements are determined by whether the furnace is in an open (unconfined) area or in a confined space such as a closet or small room.

### WARNING

READ AND FOLLOW THE *GENERAL VENTING REQUIREMENTS AND GUIDELINES* OF THIS MANUAL FOR ADDITIONAL VENTING REQUIREMENTS PERTAINING TO ALL FURNACE INSTALLATIONS (INCLUDING DIRECT AND NON-DIRECT VENTING). FAILURE TO FOLLOW ALL INSTRUCTIONS IN THIS MANUAL CAN RESULT IN EQUIPMENT FAILURE, EQUIPMENT DAMAGE, PROPERTY DAMAGE, PERSONAL INJURY OR DEATH.

## CONFINED AND UNCONFINED SPACES

The below instructions are for U.S. installations only. The terms **Confined Space** and **Unconfined Space** refer to U.S. installations only. In Canada the proper term to use is **Enclosure** when specifying that a furnace is installed in a partially enclosed or fully enclosed room or space. For Canadian installations, to determine combustion air requirements for non-direct vent installations, the installer must follow CSA B149.1; Canadian Natural Gas and Propane Installation Code and NOT the below instructions.

**TABLE 6: MINIMUM SPACE REQUIREMENTS FOR UNCONFINED SPACE, NON-DIRECT VENT**

Input (BTUH)	Minimum Space (Cubic Ft)	Minimum Area with 8ft Ceilings (sq ft)	Typical Room Size w/ 8' Ceilings (ft x ft)
56,000	2,800	350	18 x 20
70,000	3,500	438	22 x 20
84,000	4,200	525	25 x 20
98,000	4,900	613	20 x 30
112,000	5,600	700	25 x 30

### FURNACE LOCATED IN AN UNCONFINED SPACE (U.S. INSTALLATIONS) USING INDOOR AIR FOR COMBUSTION:

An unconfined space must have at least 50 cubic feet for each 1,000 BTUH of total input for all appliances in the space. **Table 6** below specifies minimum space requirements and a few examples of the room sizes required for different inputs. The sizes are based on 8-foot ceilings.

If the open space containing the furnace is in a building with tight construction, outside air may still be required for the furnace to operate and vent properly. Outside air openings should be sized the same as for a confined space.

### FURNACE LOCATED IN A CONFINED SPACE (U.S. INSTALLATIONS)

A confined space is defined as any space for a given furnace input rating which is smaller than that which is specified in **Table 6** as minimum for an "unconfined" space. If the space is less than that specified in this table, the space is defined as "confined".

If the space is small enough to be designated as "confined", it must have openings into the space which are located in accordance with the requirements set forth in the following subsections A and B. Size connected to the heated area or to the outside, and by the input of **ALL** appliances in the space.

If the confined space is within a building with tight construction, combustion air must be taken from outdoors or from an area freely communicating with the outdoors.

#### A. USING INDOOR AIR FOR COMBUSTION:

**IMPORTANT:** Air should not be taken from a heated space with a fireplace, exhaust fan or other device that may produce negative pressure.

If combustion air is taken from the heated area, the openings must each have at least 100 square inches of free area. Each opening must have at least one square inch of free area for each 1,000 BTUH of total input in the space. **Table 7** shows some typical examples of openings required for combustion air openings required for a confined space.

**TABLE 7: MINIMUM FREE AREA OPENING REQUIRED FOR A FURNACE LOCATED IN A CONFINED SPACE USING INDOOR AIR FOR COMBUSTION.**

Input (BTUH)	Free Area for Each Opening (sq inches)
56,000	100
70,000	100
84,000	100
98,000	100
112,000	120

# GENERAL VENTING REQUIREMENTS AND GUIDELINES

## NON-DIRECT VENT (cont.)

### B. USING OUTDOOR AIR FOR COMBUSTION:

**IMPORTANT:** Do not take air from an attic space that is equipped with power ventilation.

The confined space must communicate with the outdoors in accordance with Methods 1 or 2 below. The minimum dimension of air openings shall not be less than 3 inches. Where ducts are used, they shall be of the same cross-sectional area as the free area of the openings to which they connect.

**METHOD 1:**

Two permanent openings, one located within 12 inches of the top and one located within 12 inches of the bottom of the enclosure, shall be provided. The openings shall communicate directly, or by ducts, with the outdoors or spaces (crawl or attic) that freely communicate with the outdoors.

**TABLE 8: MINIMUM FREE AREA REQUIRED FOR EACH OPENING (WHEN TWO OPENINGS ARE USED) WITH A FURNACE:**

1. LOCATED IN A CONFINED SPACE
2. USING OUTDOOR AIR FOR COMBUSTION
3. COMMUNICATING DIRECTLY TO THE OUTSIDE THROUGH AN OPENING OR THROUGH A VERTICAL DUCT.

Total Input for ALL Gas Appliances (BTUH)	Free Area for Each Opening when 2 Separate Openings are used (sq inches)	Round Pipe Duct Diameter (Vertical Duct Only) (inches)
56,000	15	5
70,000	18	5
84,000	21	6
98,000	25	6
112,000	28	6

**TABLE 9: MINIMUM FREE AREA REQUIRED FOR EACH OPENING (WHEN TWO OPENINGS ARE USED) WITH A FURNACE:**

1. LOCATED IN A CONFINED SPACE
2. USING OUTDOOR AIR FOR COMBUSTION
3. COMMUNICATING DIRECTLY TO THE OUTSIDE THROUGH A HORIZONTAL DUCT.

Total Input for ALL Gas Appliances (BTUH)	Free Area for Each Opening when 2 Separate Openings are used (sq inches)	Round Pipe Duct Diameter (Horizontal Duct Only) (inches)
56,000	28	6
70,000	35	7
84,000	42	8
98,000	49	8
112,000	56	9

A. Where directly communicating with the outdoors through an opening or where communicating to the outdoors through vertical ducts as shown in **Figure 12**, each opening shall have a minimum free area of 1 square inch for each 4,000 BTUH of total appliance input rating of all equipment in the enclosure. **Table 8** below specifies the minimum area for each of the 2 combustion air openings and minimum round duct diameter for direct openings and vertical ducting only.

B. Where communicating with the outdoors through horizontal ducts, each opening shall have a minimum free area of 1 square inch for each 2,000 BTUH of total appliance input rating of all equipment in the enclosure (see **Figure 13**). **Table 9** specifies the minimum area for each of the 2 combustion air openings and minimum round duct diameter for horizontal ducting only.

**METHOD 2:**

One permanent opening located within 12 inches of the top

**TABLE 10: MINIMUM FREE AREA REQUIRED FOR AN OPENING (WHEN ONE OPENING IS USED) WITH A FURNACE:**

1. LOCATED IN A CONFINED SPACE
2. USING OUTDOOR AIR FOR COMBUSTION
3. COMMUNICATING DIRECTLY TO THE OUTSIDE.

Total Input for ALL Gas Appliances (BTUH)	Free Area for an Opening when 1 Opening is used (sq inches)	Round Pipe Duct Diameter (inches)
56,000	28	6
70,000	35	7
84,000	42	8
98,000	49	8
112,000	56	9

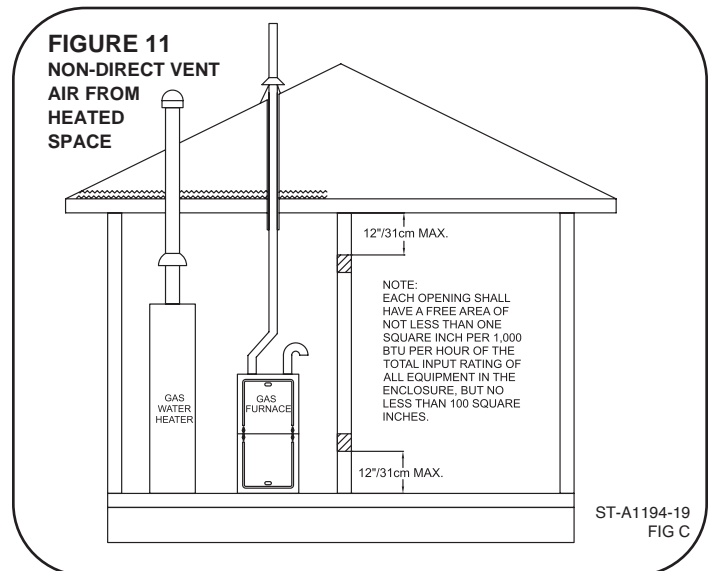

# GENERAL VENTING REQUIREMENTS AND GUIDELINES

## NON-DIRECT VENT (cont.)

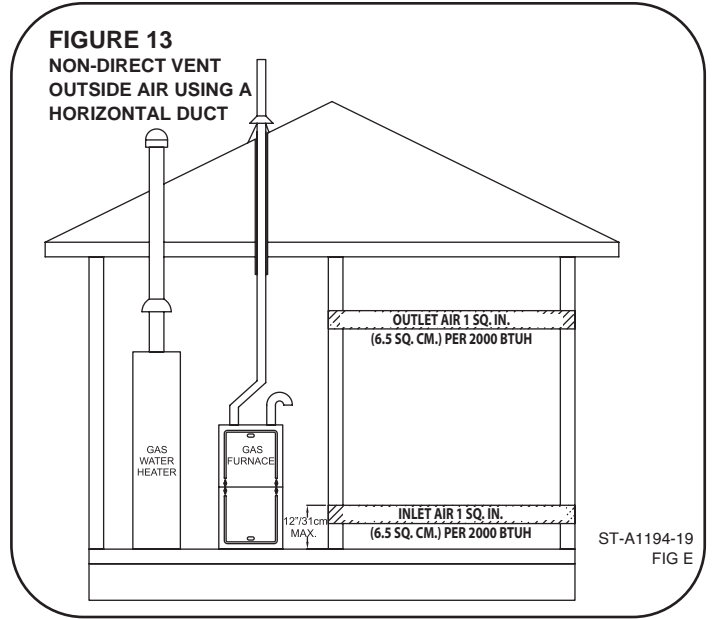
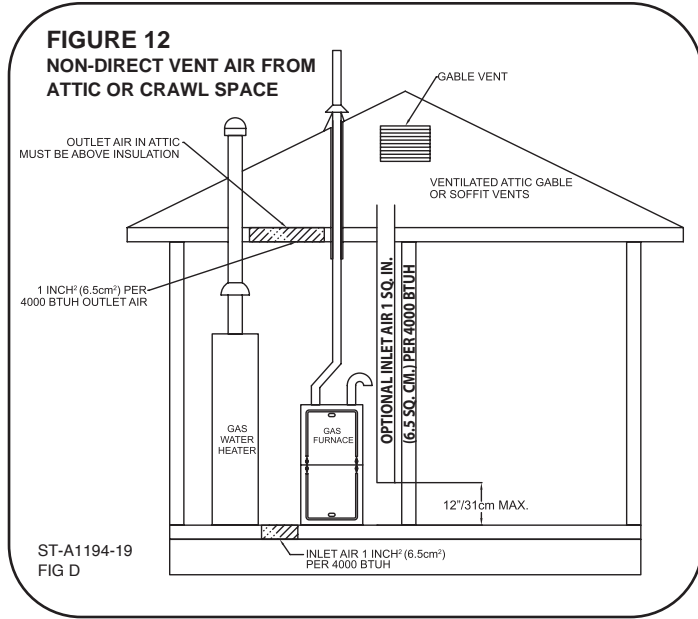

of the enclosure, shall be permitted where the equipment has clearances of at least 1 inch from the sides and back and 6 inches from the front of the appliance. The opening shall directly communicate with the outdoors or communicate through a vertical or horizontal duct to the outdoors or

spaces (crawl or attic) that freely communicate with the outdoors, and shall have a minimum of:

- A. 1 Square inch for each 3,000 BTUH of the total input rating of all equipment located in the enclosure and

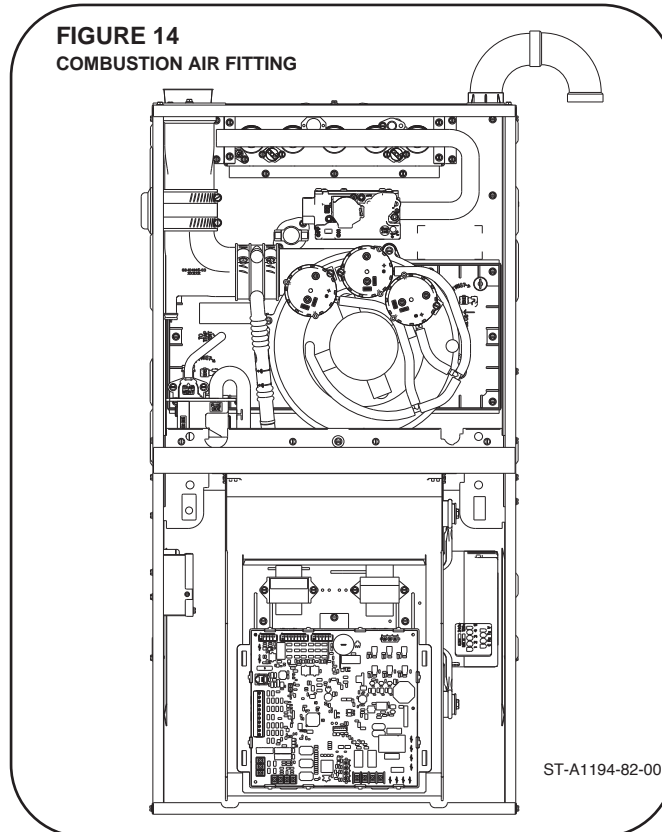



# GENERAL VENTING REQUIREMENTS AND GUIDELINES

## NON-DIRECT VENT (cont.)

- B. Not less than the sum of the areas of all vent connectors in the confined space.

If the unit is installed where there is an exhaust fan, sufficient ventilation must be provided to prevent the exhaust fan from creating negative pressure.

Combustion air openings must not be restricted in any manner.

**Figure 14** shows allowable inlet air configurations for furnaces installed with non-direct vent.

**IMPORTANT:** When indoor combustion air is used, the inlet air opening at the furnace must be protected from accidental blockage (see **Figure 14**).

### WARNING

**DO NOT USE VENT TERMINATIONS WHICH ARE NOT SPECIFIED IN THESE INSTRUCTIONS. USING VENT TERMINATIONS OTHER THAN THOSE SPECIFIED HERE CAN RESULT IN ERRATIC OPERATION, EQUIPMENT FAILURE OR PERSONAL INJURY OR DEATH FROM CARBON MONOXIDE POISONING.**

### CAUTION

**ALL VENTS INSTALLED THROUGH UNCONDITIONED SPACE WHERE BELOW-FREEZING TEMPERATURES ARE EXPECTED SHOULD BE INSULATED WITH APPROVED INSULATION MATERIAL. MATERIAL SUCH AS ARMAFLEX OR RUBATEX INSULATION MAY ALSO BE USED AS LONG AS THERE IS NO HEAT TAPE IS APPLIED TO THE VENT PIPE. FAILURE TO INSULATE THE PIPE COULD RESULT IN FREEZING OF WATER IN THE PIPE THEREBY BLOCKING THE PIPE AND PREVENTING FURNACE OPERATION.**

### VERTICAL TERMINATION

**Figure 15** shows a standard non-direct vertical vent termination with clearances.

## NON-DIRECT VENTING TERMINATIONS

These furnaces are design-certified to use a single vent pipe where all combustion air is taken from indoors and can be vented vertically only (no horizontal non-direct venting is permitted).

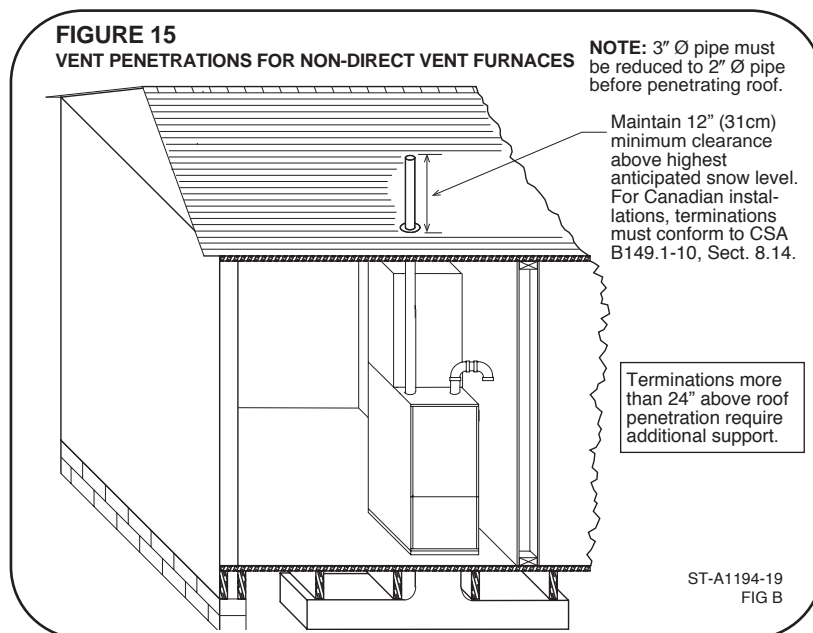

# GENERAL VENTING REQUIREMENTS AND GUIDELINES

## DIRECT VENT

### ▲ WARNING

ALL FURNACE INSTALLATIONS MUST COMPLY WITH THE NATIONAL FUEL GAS CODE OR, IN CANADA, CSA B149.1; NATURAL GAS AND PROPANE INSTALLATION CODE AND LOCAL CODES TO PROVIDE ADEQUATE COMBUSTION AND VENTILATION AIR FOR THE FURNACE. FAILURE TO DO SO CAN RESULT IN EXPLOSION, FIRE, PROPERTY DAMAGE, CARBON MONOXIDE POISONING, PERSONAL INJURY OR DEATH.

### ▲ WARNING

READ AND FOLLOW THE *GENERAL VENTING REQUIREMENTS AND GUIDELINES* OF THIS MANUAL FOR ADDITIONAL VENTING REQUIREMENTS PERTAINING TO ALL FURNACE INSTALLATIONS (INCLUDING DIRECT AND NON-DIRECT VENTING). FAILURE TO FOLLOW ALL INSTRUCTIONS IN THIS MANUAL CAN RESULT IN EQUIPMENT FAILURE, EQUIPMENT DAMAGE, PROPERTY DAMAGE, PERSONAL INJURY OR DEATH.

## DIRECT-VENT (2-PIPE) INSTALLATIONS

The field-supplied vent system used for direct-vent installations uses 2 pipes; one inlet pipe for supplying the combustion air to the furnace, and an exhaust (or flue) pipe for transferring the flue products to the outside. The flue pipe is elevated at least 12 inches above the air intake pipe for all vertical installations to prevent flue gas recirculation during operation.

The furnace combustion air inlet must be located a minimum safe distance from the vent of any other gas or fuel-burning appliance or clothes dryer to prevent recirculation of the flue gases into the furnace combustion air inlet. Reference National Fuel Gas Code current edition in Canada CSA149.1 current edition for minimum distances. The only exception to this requirement is the case of multiventing two or more furnaces, which is covered in the section on multiventing of these instructions.

Direct-Vent systems must be installed so that the vent and combustion air intake pipes terminate in the same atmospheric pressure zone.

### OPTION 1: STANDARD VERTICAL DIRECT-VENT TERMINATION

Figure 16 below shows a standard vertical termination for direct venting installations. Maintain the dimensions specified in this drawing for vertical venting of direct-vent furnace installations. Specific details of the roof penetration can be found in Figure 17.

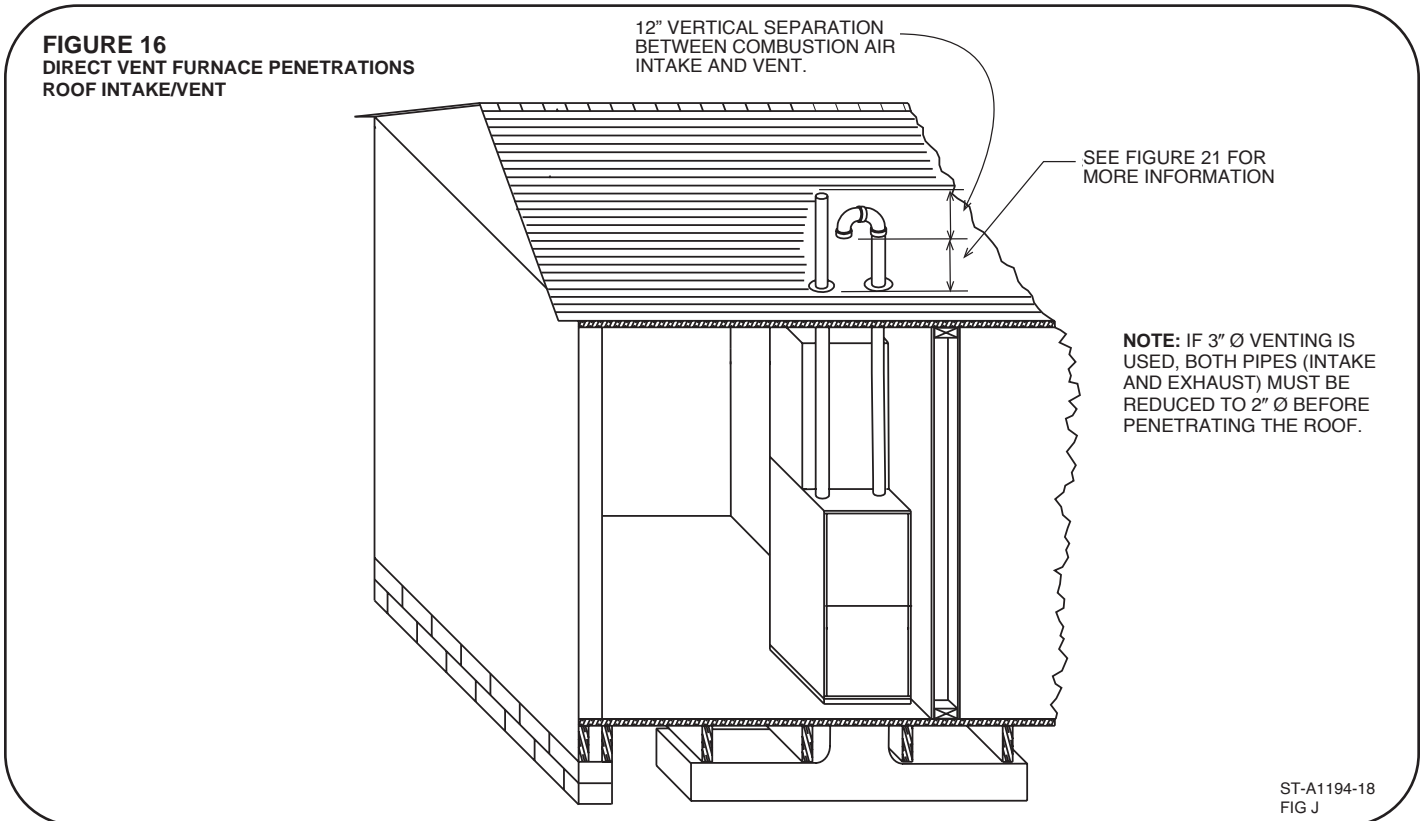

# GENERAL VENTING REQUIREMENTS AND GUIDELINES

## DIRECT VENT (cont.)

Figure 17 below shows the necessary detail for the roof penetration on a standard direct-vent vertical termination.

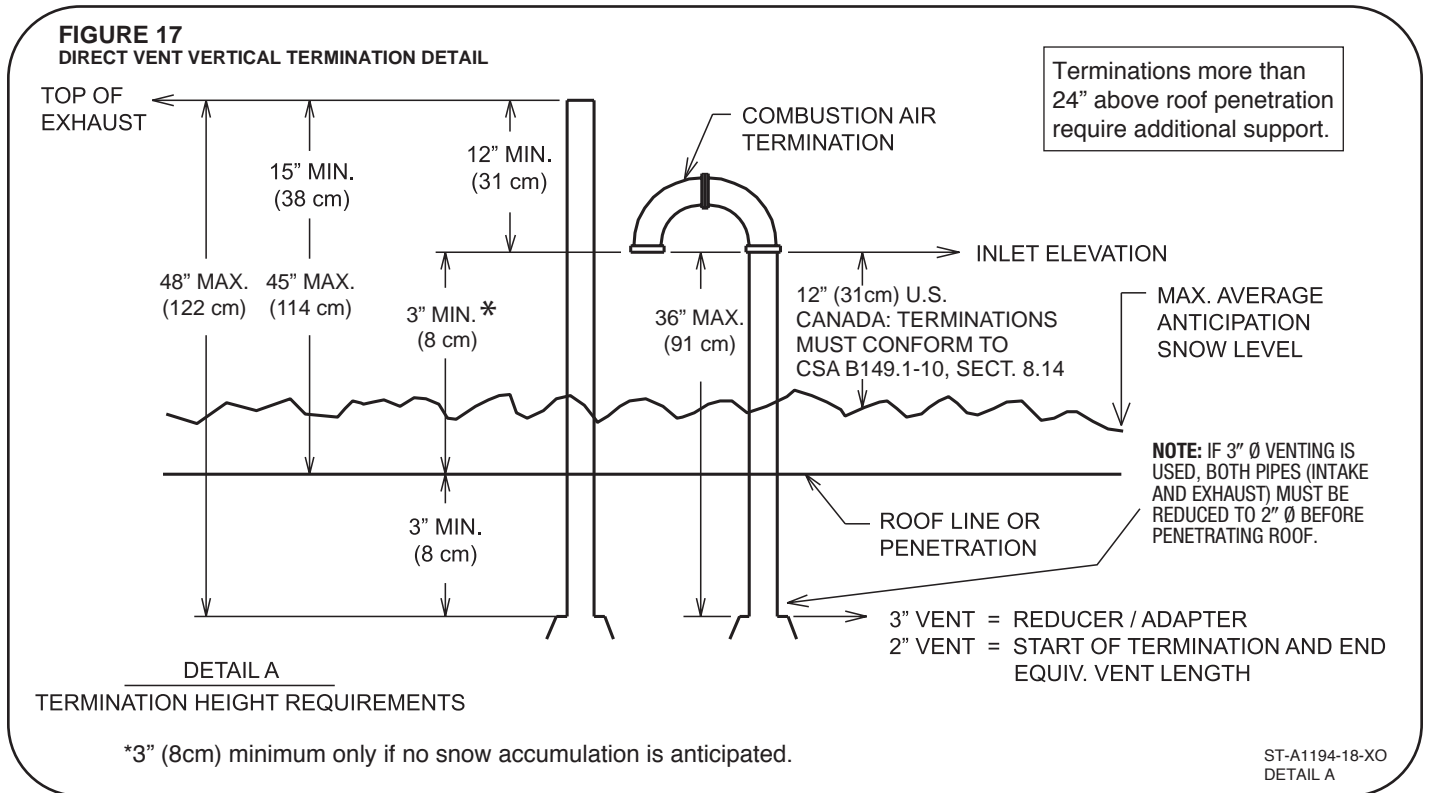

\*3" (8cm) minimum only if no snow accumulation is anticipated.

# GENERAL VENTING REQUIREMENTS AND GUIDELINES

## DIRECT VENT (cont.)

### OPTION 2: STANDARD HORIZONTAL DIRECT-VENT TERMINATION

**FIGURE 18**  
STANDARD HORIZONTAL DIRECT VENTING

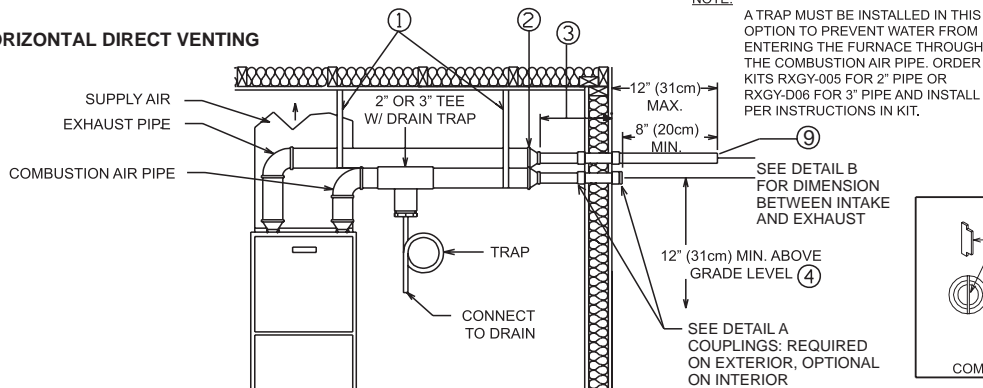

**NOTES:**

- 1) SUPPORT HORIZONTAL PIPE EVERY FOUR FEET.
- 2) WHEN 3" PIPE IS USED REDUCE TO 2" BEFORE PENETRATING OUTSIDE WALL.
- 3) WHEN USING 3" Ø VENT AND NECKING DOWN TO 2" Ø AS REQUIRED, 18" (46cm) MAX. 2" DIA. PIPE MAY BE USED INSIDE THE WALL.
- 4) INCREASE THE 12" (31cm) MIN. (U.S.) ABOVE GRADE TO KEEP TERMINAL OPENINGS ABOVE ANTICIPATED LEVEL OF SNOW ACCUMULATION WHERE APPLICABLE. CANADA: TERMINATIONS MUST CONFORM TO CSA B149.10, SECT. 8.14.
- 5) DETAIL "B" INSTALL WIND DEFLECTOR VANE IN 2" PVC COUPLING IN VERTICAL POSITION USING PVC SOLVENT.
- 6) THE COMBUSTION AIR TERMINATION MUST BE IN THE SAME PRESSURE ZONE AS THE EXHAUST TERMINATION.
- 7) NO SCREENS MAY BE USED TO COVER COMBUSTION AIR OR EXHAUST.
- 8) NO T'S CAN BE INSTALLED AT THE TERMINATION.
- 9) WALL PENETRATION AND VENT TERMINATIONS MUST BE WITH 2" Ø PIPE.

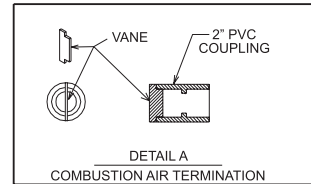
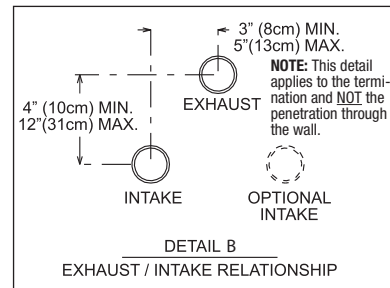

ST-A1194-18-XO  
FIGURE K &  
DETAILS B & C

### OPTION 3: VARIANT OF STANDARD HORIZONTAL DIRECT-VENT TERMINATION

**FIGURE 19**  
VARIANT OF STANDARD HORIZONTAL DIRECT-VENT TERMINATION

- NOTE:**
- 1) A TRAP IN THE COMBUSTION AIR PIPE IS NOT REQUIRED FOR THIS OPTION.
  - 2) PIPING EXTERNAL TO THE STRUCTURE MUST BE INSULATED AS REQUIRED FOR LOCAL CLIMATE.
  - 3) WALL PENETRATIONS AND VENT TERMINATIONS MUST BE WITH 2" Ø PIPE. WHEN USING 3" Ø VENT AND NECKING DOWN TO 2" Ø AS REQUIRED, A MAXIMUM OF 18" OF 2" Ø PIPE IS PERMITTED INSIDE (BEFORE THE PENETRATION) WHEN USING 3" Ø VENT.

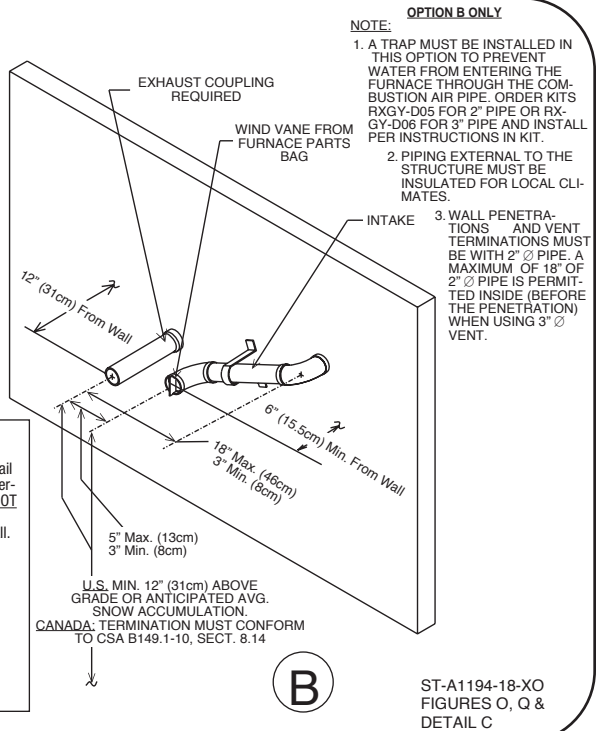
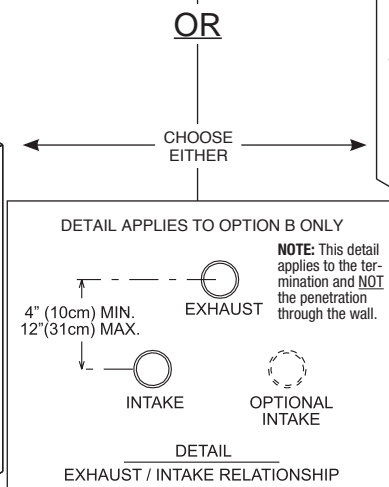
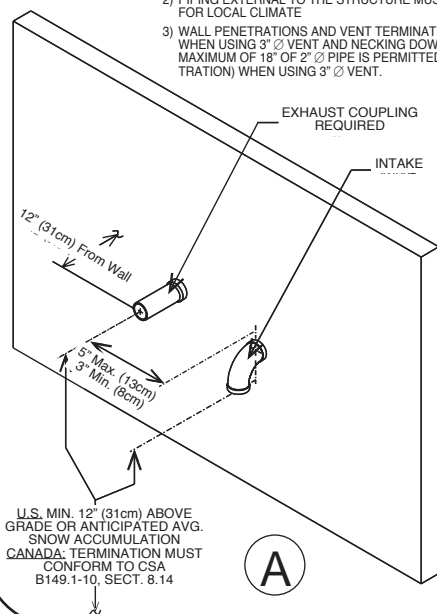

ST-A1194-18-XO  
FIGURES O, Q &  
DETAIL C

# GENERAL VENTING REQUIREMENTS AND GUIDELINES

## DIRECT VENT (cont.)

### OPTION 4: ALTERNATE HORIZONTAL DIRECT-VENT TERMINATION

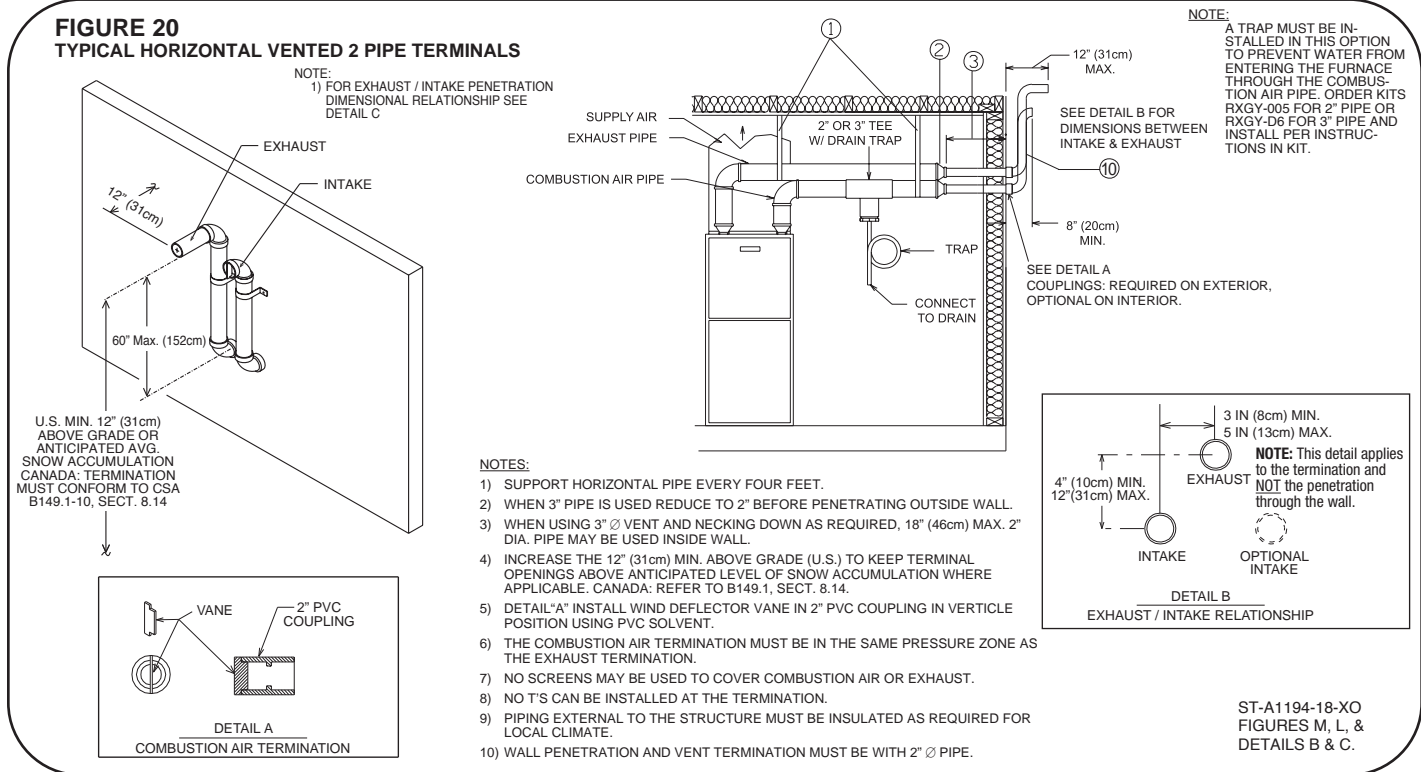

### OPTION 5: VARIANT OF ALTERNATE HORIZONTAL DIRECT-VENT TERMINATION

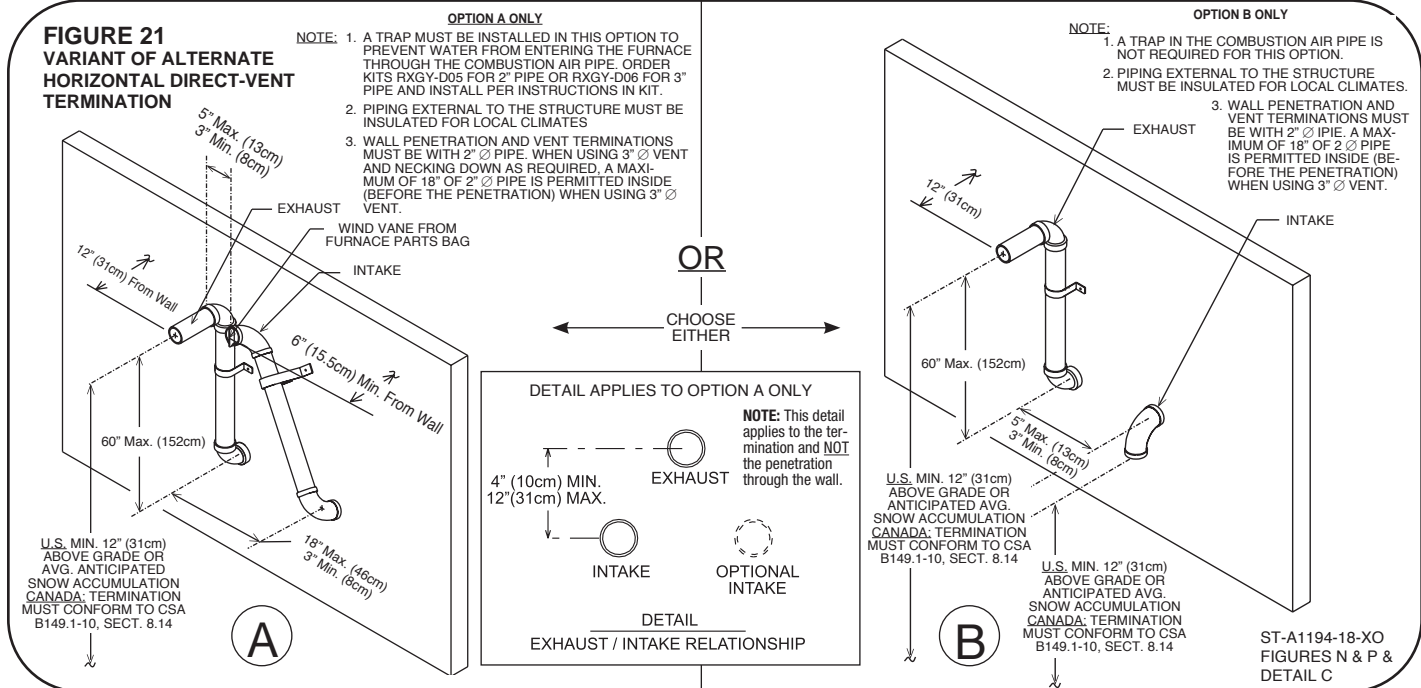

# GENERAL VENTING REQUIREMENTS AND GUIDELINES

## DIRECT VENT (cont.)

### OPTIONAL TERMINATION ANGLES FOR OPTION FOR ALT. HORIZ. AND VARIANT OF ALT. HORIZ. DIRECT-VENT TERMINATIONS (OPTIONS 4 & 5)

**NOTE:** These optional termination angles apply only to direct-vent termination options 4 and 5 above (alternate horizontal and variant of optional horizontal) in this section. Do not use these angled terminations with any other termination option.

**NOTE:** This option is recommended for installations where the distance from the vent pipe perpendicular to another structure is less than 10 feet.

Top view for using 22° or 45° termination on a single furnace.

Using alternate vent terminations from options 4 or 5 above, simply rotate the final elbows 22 or 45 degrees from the wall as shown below.

- Both the combustion air and exhaust final termination elbows must be at the same angle and face the same direction (left or right).
- A wind vane must be installed in the combustion air inlet pipe as shown in the diagram.
- Number and distance between (recommended) support straps must provide rigid support.

- Mark the final (22° or 45°) angles on the top of the vertical risers and final elbows before gluing into place to ensure that the final angles are correct.
- Insulating the exhaust termination vertical riser may be necessary in some areas, depending on the total length and expected temperatures in the area.
- Do not angle (22° or 45°) into an inside corner.
- Do not use screens on the inlet or exhaust pipes.
- Angled terminations cannot be used on pairs of vents.
- This termination may cause discoloration over time to the external surface of the structure.
- Wall penetrations and vent terminations must be with 2"  $\varnothing$  pipe to reduce the possibility of ice forming at the termination. A maximum of 18" of 2"  $\varnothing$  pipe is permitted inside (before the penetration) when using 3"  $\varnothing$  vent.

FIGURE 22

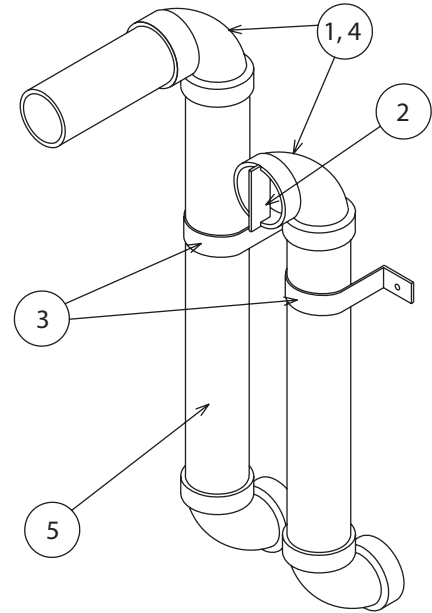
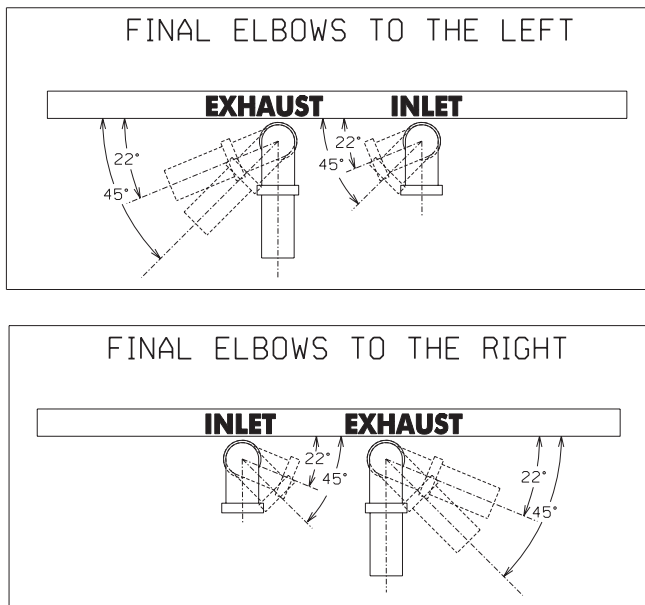

ST-A1194-20

# GENERAL VENTING REQUIREMENTS AND GUIDELINES

## DIRECT VENT (cont.)

**OPTIONS 6 & 7: VERTICAL OR HORIZONTAL CONCENTRIC VENT TERMINATION**  
**FOR 2" PIPE: RXGY-E02 (U.S. ONLY) OR RXGY-E02A (U.S. AND CANADA)**  
**FOR 3" PIPE: RXGY-E03 (U.S. ONLY) OR RXGY-E03A (U.S. AND CANADA)**

### CONCENTRIC TERMINATIONS

These kits are for vertical/horizontal intake air/vent runs and may be installed through roofs or sidewalls. One 5 inch diameter hole (RXGY-E03 & RXGY-E03A) or 3-5/8 inch diameter hole (RXGY-E02 & RXGY-E02A) is required for the installation. See **Figure 23** for the general layout. Complete instructions are included with each kit.

**NOTE:** The following IPEX brand concentric vent termination (System 636) may be purchased in the field and used in place of the kits offered by the furnace manufacturer.

3" Concentric Vent Kit = Item #196006

**NOTE:** Maximum equivalent lengths specified in the **VENT PIPE SIZING AND MAXIMUM VENT LENGTHS** section of this manual are in addition to the concentric vent.

**NOTE:** With this option a trap on the inlet air pipe is NOT required.

**FIGURE 23**  
**CONCENTRIC VENT KIT NO. RXGY-E02A (2") AND**  
**RXGY-E03A (3")**

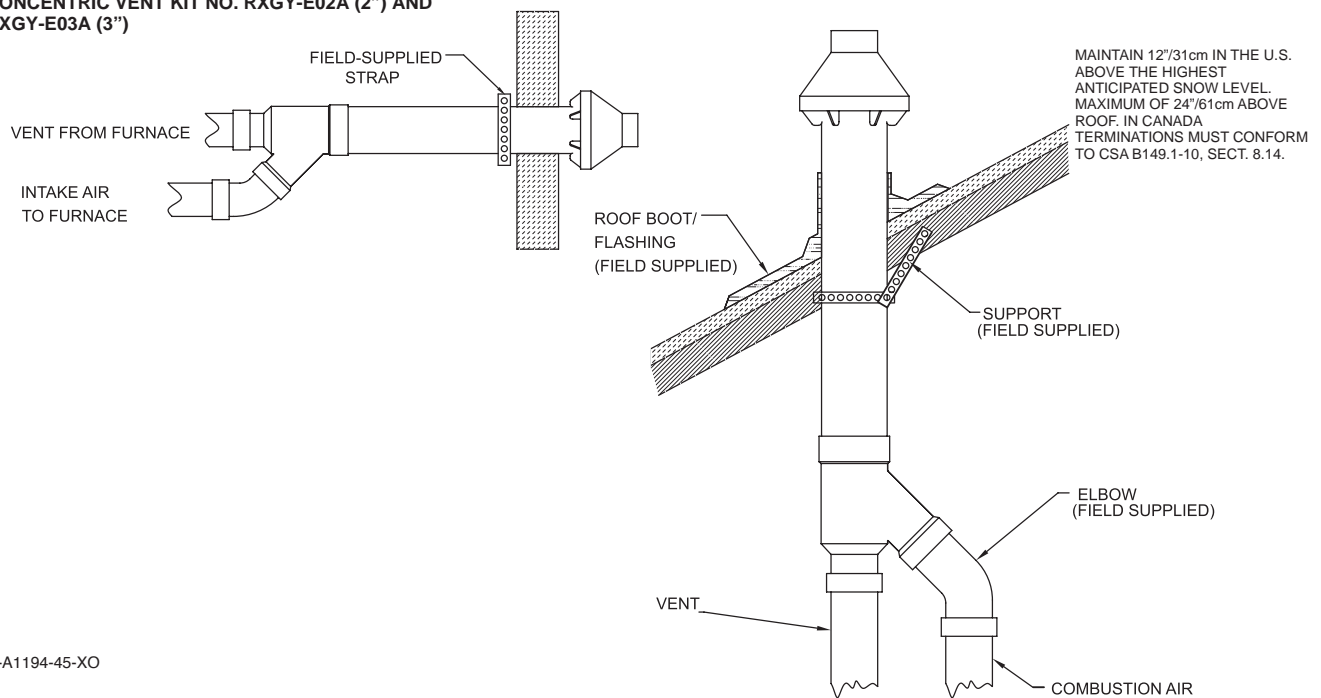

ST-A1194-45-XO

# GENERAL VENTING REQUIREMENTS AND GUIDELINES

## DIRECT VENT (cont.)

### OPTIONS 8 & 9: 2" & 3" SIDE WALL VENT TERMINATIONS (Figures 24 & 25)

**FOR 2" PIPE: RXGY-G02**

**FOR 3" PIPE: RXGY-G01**

This termination is for horizontal venting only. This termination may be installed with either a non-direct-vent or a direct-vent system. When installed as non-direct vent, only one wall penetration is necessary for the exhaust vent.

**IMPORTANT:** Do not install on the prevailing winter wind side of the structure.

**IMPORTANT:** Maintain a minimum of 12 inches (U.S.) above grade or the highest anticipated average snow level (whichever is greater) to the bottom of the vent cover or, in Canada, terminations must conform with CSA B149.1-10, Sect. 8.14, Canadian Natural Gas and Propane Installation Code.

**NOTE:** Dimensions between the inlet and outlet pipes (direct-vent only) are fixed by the sidewall termination. Other drawings in this manual which specify minimum and/or maximum distances (vertical and horizontal) between pipes do not apply to the sidewall termination kit.

**NOTE:** Multiventing – NO COMMON VENTING IS PERMITTED WITH THIS KIT.

**NOTE:** With this option a trap on the inlet combustion air pipe is NOT required.

**NOTE:** Install the vent and air intake piping into the vent plate openings. Seal all gaps between the pipes and wall. **BE SURE TO USE SILICONE SEALANT** to seal the vent pipe to the vent cap to permit field disassembly for annual inspection and cleaning. Also seal all pipe penetrations in the wall. **DO NOT INSTALL VENT KITS ONE ABOVE THE OTHER** to prevent the possibility of condensate freeze-up or recirculation.

**NOTE:** Vent should protrude a maximum of 2-¼ inches beyond the vent plate. Air intake should protrude a maximum of 1 inch beyond the vent plate.

**NOTE:** The RXGY-G02 termination can be used with 3" vent pipe. A maximum of 18" of 2" Ø pipe can be used before penetrating the wall.

Complete installation instructions are included with these kits.

**FIGURE 24**  
VENT KIT INSTALLATION OPTIONS

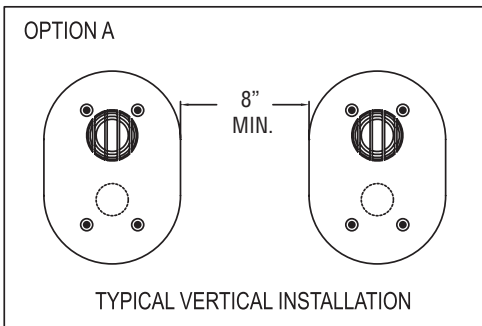

ST-A1194-46

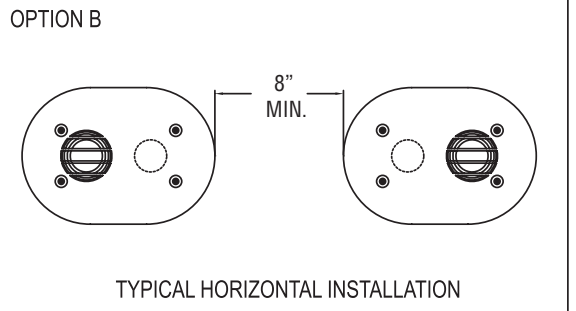

**FIGURE 25**  
TYPICAL INSTALLATION – DIRECT VENT

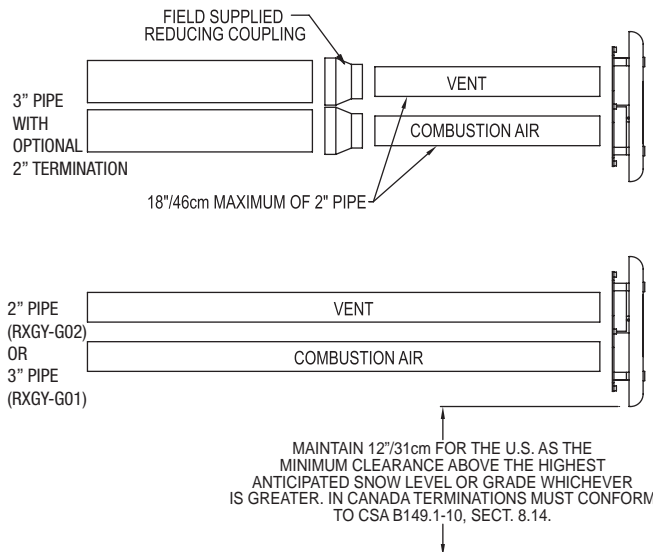

ST-A1194-46



# GENERAL VENTING REQUIREMENTS AND GUIDELINES

## DIRECT VENT TERMINATION CLEARANCES

Figure 26 shows minimum clearances that must be used for direct venting terminations.

**FIGURE 26**  
DIRECT VENT TERMINAL CLEARANCES

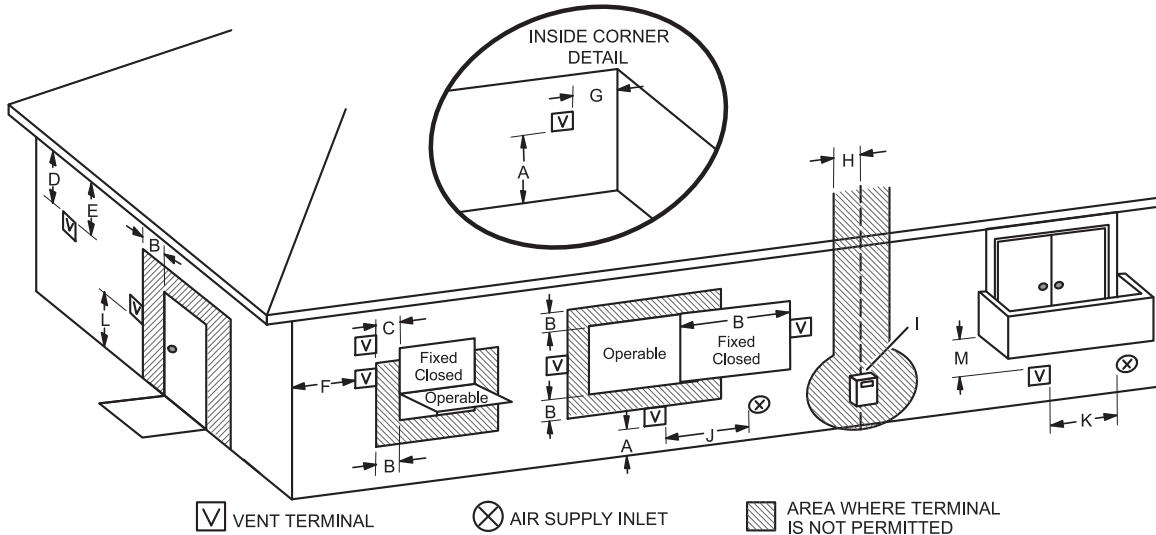

	US Installations <sup>1</sup>	Canadian Installations <sup>2</sup>
A = Clearance above grade, veranda, porch, deck or balcony	12 inches (305mm) or 12 in. 305mm) above average snow accumulation.	Must conform to CSA B149.1-10, Sect. 8.14.
B = Clearance to window or door that may be opened	6 inches (152mm) for appliances <10,000 Btuh (3kw), 12 inches (305mm) for appliances >10,000 Btuh (3kw), and <100,000 Btuh (30kw), 36 inches (.9m) for appliances > 100,000 Btuh (30kw)	6 inches (15cm) for appliances <10,000 Btuh (3kw), 12 inches (305mm) for appliances >10,000 Btuh (3kw), and <100,000 Btuh (30kw), 36 inches (.9m) for appliances > 100,000 Btuh (30kw)
C = Clearance to permanently closed window	* 12" (30cm)	* 12" (30cm)
D = Vertical clearance to ventilated soffit located above the terminal within a horizontal distance of 2 feet (0.6m) from the center line of the terminal	* Equal to or greater than soffit depth	* 3 ft. (0.9m)
E = Clearance to unventilated soffit	* Equal to or greater than soffit depth	* 2 ft. (0.6m)
F = Clearance to outside corner	* No minimum to outside corner	* No minimum to outside corner
G = Clearance to inside corner	* 3 ft. (.9m), 10 ft. (3.05 m) preferred	* 3 ft. (.9m), 10 ft. (3.05m) preferred
H = Clearance to each side of center line extended above meter / regulator assembly	3 feet (.9m) within a height 15 feet (4.5m) above the meter / regulator assembly	3 feet (.9m) within a height 15 feet (4.5m) above the meter / regulator assembly
I = Clearance to service regulator vent outlet	3 feet (.9m)*	*3 feet (.9m)
J = Clearance to non-mechanical air supply inlet to building or the combustion air inlet to any other appliance	6 inches (152mm) for appliances <10,000Btuh (3kw), 12 inches (305mm) for appliances > 10,000 Btuh (3kw) and <100,000 Btuh (30kw), 36 inches (.9m)for appliances > 100,000 Btuh (30kw)	6 inches (15cm) for appliances <10,000Btuh (3kw), 12 inches (30cm) for appliances > 10,000 Btuh (3kw) and <100,000 Btuh (30kw), 36 inches (.9m)for appliances > 100,000 Btuh (30kw)
K = Clearance to mechanical air supply inlet	3 feet (.9m) above if within 10 feet (3m) horizontally	6 feet (1.8m)
L = Clearance above paved sidewalk or paved driveway located on public property	* 7 feet (2.1m)	7 feet (2.1m)†
M = Clearance under veranda, porch, deck or balcony	*12 inches (305mm)‡	12 inches (30cm) ‡

<sup>1</sup> In accordance with the current ANSI Z223.1/NFPA 54 Natural Fuel Gas Code

<sup>2</sup> In accordance with the current CSA B149.1, Natural Gas and Propane Installation Code

† Vent shall not terminate less than 7 ft. (2.1m) above a paved sidewalk or paved driveway that is located on public property.

‡ Permitted only if veranda, porch, deck or balcony is full open on a minimum of two sides beneath the floor. We recommend avoiding this location if possible.

\*For clearances not specified in ANSI Z223.1/NFPA 54 or CSA B149.1, clearance will be in accordance with local installation codes and the requirements of the gas supplier and these installation instructions.\*

# GENERAL VENTING REQUIREMENTS AND GUIDELINES

## MULTIVENTING OF DIRECT-VENT FURNACES

**Figures 27 & 28:** NOTE: WHEN VENTING MULTIPLE FURNACES IN CLOSE PROXIMITY, EACH FURNACE MUST BE INDIVIDUALLY VENTED – NO COMMON VENTING IS PERMITTED. See **Figures 27 & 28** for positioning of the terminations. When more than two furnaces are to be vented, there must be at least 4 feet between the first two furnaces and the third and etc. **Figure 27, (Detail A)** below shows the necessary detail for the roof penetration on a standard direct-vent vertical termination.

**FIGURE 27**  
TWO FURNACE VENTING

**TWO PIPE VENTING THROUGH ROOF**

TERMINATIONS MORE THAN 24" ABOVE ROOF PENETRATION REQUIRE ADDITIONAL SUPPORT.

**NOTE:** IF 3" Ø VENTING IS USED, BOTH PIPES (INTAKE AND EXHAUST) MUST BE REDUCED TO 2" Ø BEFORE PENETRATING ROOF.

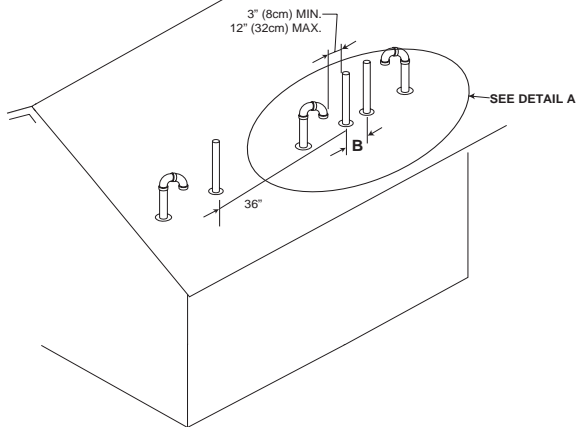

**TWO PIPE VENTING THROUGH WALL**

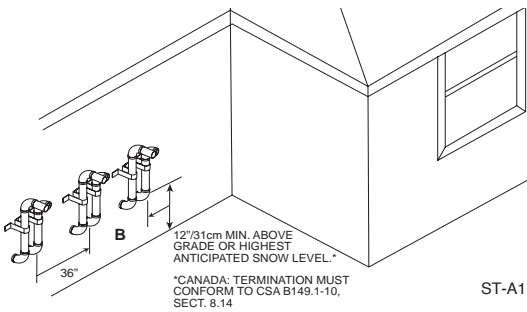

ST-A1194-21-01

**DIRECT VENT VERTICAL TERMINATION DETAIL**

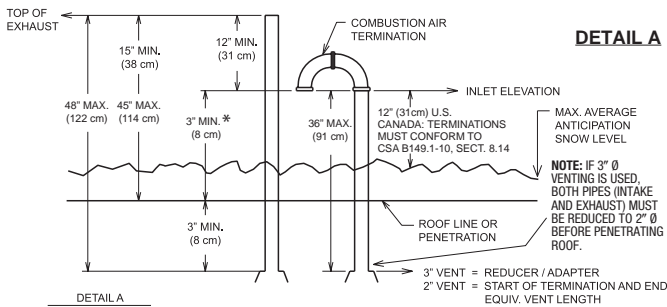

TERMINATION HEIGHT REQUIREMENTS

\*3" (8cm) minimum only if no snow accumulation is anticipated.

ST-A1194-18  
DETAIL A

**FIGURE 28**  
TWO FURNACE VENTING WITH CONCENTRIC VENTING

**CONCENTRIC VENTING THROUGH ROOF**

MINIMUM 12"/31cm IN U.S. ABOVE AVERAGE SNOW ACCUMULATION. MAXIMUM OF 24"/61cm ABOVE ROOF.\*

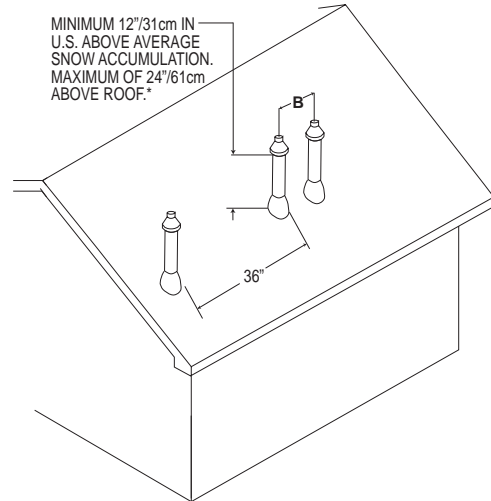

**CONCENTRIC VENTING THROUGH WALL**

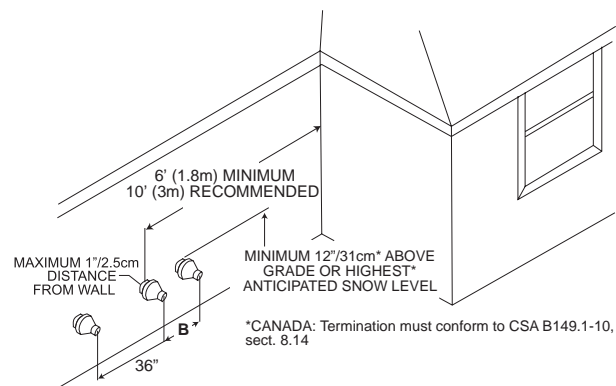

ST-A1194-22-01

**For 2 Direct Vent Furnace Installations**

- B 1. Terminations must be 9-24" apart.
- 2. Canada: 12" (300mm) for inputs 10k Btuh (3kW) up to and including 100K Btuh (30kW)  
36" (900mm) for inputs exceeding 100K Btuh (30kW)

**For 3 or More Direct Vent Furnace Installations**

Furnace terminations require 36" between each additional pair of terminations for US and Canada.

# CONDENSATE DRAIN

## CONDENSATE DRAIN & DRAIN NEUTRALIZER

### GENERAL INFORMATION

#### CAUTION

**DO NOT RUN DRAIN OUTDOORS. FREEZING OF CONDENSATE CAN CAUSE PROPERTY DAMAGE.**

**IMPORTANT:** Do not connect into a common drain line with an air conditioner evaporator coil drain located below the furnace. A blocked or restricted drain line can result in overflow of the coil pan and negate the furnace blocked drain shutoff control.

The condensate drain trap is self-priming. Upon the first heat attempt after installation or the first ignition after a long off period (e.g. summer), the trap will be dry allowing air to pull through the trap and causing the condensate to be held in the collector box by the negative pressure while the inducer is energized.

Condensate builds up in the collector box until the level reaches the electronic water level sensor. When this happens the heat attempt is ended thus shutting off the inducer after a post purge. This relieves the negative pressure pulled through the trap and the water then falls into the trap generally priming it after the first time. Note that in some circumstances this process may be repeated up to four times before the trap is fully primed – particularly in horizontal installations where there is less volume of water in the collector box below the water level sensor.

**Important:** There are two options when choosing a height for the condensate vent riser (also see Figure 29):

A. **CONDENSATE OVERFLOW** – When the top of the vent tube is below the elevation of the LOWER condensate water level sensor (aka electronic water level sensor) the furnace will continue to run even if the drain is blocked. A blocked drain will cause the condensate water to overflow the vent and spill water on the floor below it but the furnace will continue to run and heat will be provided. If the installer uses this approach, he must make sure that there is a mechanism for handling the possibility of water overflow onto the floor in the event of a blocked drain.

B. **FURNACE SHUTOFF** – When the top of the vent tube is above the elevation of the LOWER condensate water level sensor (aka electronic water level sensor), the furnace will be shut off in the event of a blocked drain and no heat will be provided.

**NOTE:** IT IS IMPORTANT ANY TIME THE FURNACE IS INSTALLED IN AN ENVIRONMENT WHERE THE TEMPERATURE CAN GET BELOW FREEZING THAT THE TRAP AND ALL CONDENSATE LINE BE PROTECTED FROM FREEZING. IF THE FURNACE IS EXPOSED TO TEMPERATURES BELOW FREEZING, THE TRAP WILL FREEZE AND THIS WILL CAUSE THE FURNACE TO SHUT DOWN AND/OR DAMAGE THE DRAIN TRAP UNLESS FREEZE PROTECTION IS INSTALLED.

If local codes require, install a condensate neutralizer cartridge in the drain line. Install cartridge in horizontal position only. Also install an overflow line if routing to a floor drain. See Figure 29.

If no floor drain is available, install a condensate pump that is resistant to acidic water. Pumps are available from your local distributor. If pump used is not resistant to acidic water, a condensate neutralizer must be used ahead of the pump. The condensate pump must have an auxiliary safety switch to prevent operation of the furnace and resulting overflow of condensate in the event of pump failure. The safety switch must be wired through the “R” circuit only (low voltage) to provide operation in either heating or cooling modes.

For Econet-enabled systems, the condensate overflow switch can be connected to the auxiliary inputs on the furnace control. See section titled “Auxiliary Inputs” in the Furnace Control section.

# CONDENSATE DRAIN

## CONDENSATE DRAIN & DRAIN NEUTRALIZER (cont.)

FIGURE 29

### CONDENSATE DRAIN LOCATING INSTRUCTIONS

NOTE:  
THIS IMAGE INTENTIONALLY DEPICTS A GENERIC VIEW OF THE DRAIN ROUTING. THE INSTALLER HAS THE OPTION TO ROUTE THE DRAIN TO THE RIGHT OR LEFT OF THE FURNACE AS NEEDED.

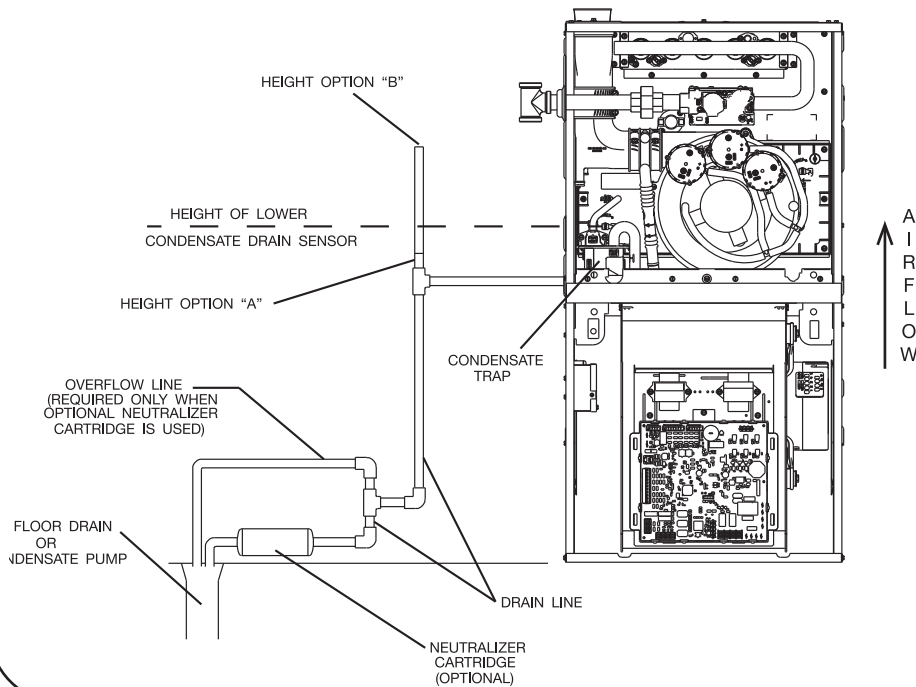

### VENT TUBE HEIGHT

VENT TUBE HEIGHT IS OPTIONAL:

**OPTION A:** INSTALL VENT TUBE HEIGHT WITH TOP OF THE TUBE BELOW THE LEVEL OF THE WATER SENSOR TO ALLOW THE FURNACE TO RUN WHEN THE DRAIN IS BLOCKED. THIS OPTION WILL SPILL WATER OUT OF THE TUBE WHEN THE DRAIN IS BLOCKED, BUT THE FURNACE WILL CONTINUE TO RUN.

**OPTION B:** INSTALL VENT TUBE HEIGHT WITH TOP OF THE TUBE ABOVE THE LEVEL OF THE LOWER CONDENSATE WATER SENSOR TO SHUT THE FURNACE DOWN WHEN THE DRAIN IS BLOCKED. THIS OPTION WILL NOT SPILL WATER FROM THE DRAIN VENT, BUT THE FURNACE WILL ALSO NOT CONTINUE TO RUN WITH A BLOCKED DRAIN.

ST-A1194-70-00

# GAS SUPPLY

## GAS SUPPLY AND PIPING

### IMPORTANT SAFETY INFORMATION

#### NATURAL GAS AND PROPANE (LIQUEFIED PETROLEUM GAS / LPG) SAFETY

#### GAS SUPPLY

##### **WARNING**

- FURNACES USING PROPANE GAS ARE DIFFERENT FROM NATURAL GAS MODELS. A NATURAL GAS HEATER WILL NOT FUNCTION SAFELY ON PROPANE AND VICE VERSA. CONVERSIONS OF HEATER GAS TYPE SHOULD ONLY BE MADE BY QUALIFIED INSTALLERS USING FACTORY SUPPLIED COMPONENTS. THE FURNACE SHOULD ONLY USE THE FUEL TYPE IN ACCORDANCE WITH LISTING ON RATING PLATE. ANY OTHER FUEL USAGE WILL RESULT IN DEATH OR SERIOUS PERSONAL INJURY FROM FIRE AND/OR EXPLOSION.
- BOTH NATURAL GAS AND PROPANE HAVE AN ODORANT ADDED TO AID IN DETECTING A GAS LEAK. SOME PEOPLE MAY NOT PHYSICALLY BE ABLE TO SMELL OR RECOGNIZE THIS ODORANT. IF YOU ARE UNSURE OR UNFAMILIAR WITH THE SMELL OF NATURAL GAS OR PROPANE, ASK YOUR LOCAL GAS SUPPLIER. OTHER CONDITIONS, SUCH AS “ODORANT FADE,” WHICH CAUSES THE ODORANT TO DIMINISH IN INTENSITY, CAN ALSO HIDE, CAMOUFLAGE, OR OTHERWISE MAKE DETECTING A GAS LEAK BY SMELL MORE DIFFICULT.
- UL OR CSA RECOGNIZED FUEL GAS DETECTORS ARE RECOMMENDED IN ALL ENCLOSED PROPANE AND NATURAL GAS APPLICATIONS WHEREIN THERE IS A POTENTIAL FOR AN EXPLOSIVE MIXTURE OF FUEL GAS TO ACCUMULATE. FUEL DETECTOR INSTALLATION SHOULD BE IN ACCORDANCE WITH THE DETECTOR MANUFACTURER’S RECOMMENDATIONS AND/OR LOCAL LAWS, RULES, REGULATIONS, OR CUSTOMS.
- BEFORE ATTEMPTING TO LIGHT THE FURNACE, MAKE SURE TO LOOK AND SMELL FOR GAS LEAKS. USE A SOAPY SOLUTION TO CHECK ALL GAS FITTINGS AND CONNECTIONS.

BUBBLING AT A CONNECTION INDICATES A LEAK THAT MUST BE CORRECTED. WHEN SMELLING TO DETECT A GAS LEAK, BE SURE TO ALSO SNIFF NEAR THE FLOOR. PROPANE GAS IS HEAVIER THAN AIR AND TENDS TO COLLECT AT LOWER LEVELS MAKING IT MORE DIFFICULT TO SMELL AT NOSE LEVEL. NATURAL GAS IS LIGHTER THAN

*(Continued on next column)*

AIR AND WILL RISE, POSSIBLY ACCUMULATING IN HIGHER PORTIONS OF THE STRUCTURE.

- **IF A GAS LEAK IS PRESENT OR SUSPECTED:**
  - **DO NOT** ATTEMPT TO FIND THE CAUSE YOURSELF.
  - **NEVER** USE AN OPEN FLAME TO TEST FOR GAS LEAKS. THE GAS CAN IGNITE RESULTING IN DEATH, PERSONAL INJURY, OR PROPERTY DAMAGE.
  - **DO NOT** TRY TO LIGHT ANY APPLIANCE.
  - **DO NOT** TOUCH ANY ELECTRICAL SWITCH.
  - **DO NOT** USE ANY PHONE IN YOUR BUILDING.
  - LEAVE THE BUILDING IMMEDIATELY AND CALL THE GAS SUPPLIER FROM A NEIGHBOR’S PHONE. FOLLOW THE GAS SUPPLIER’S INSTRUCTIONS.
  - IF YOU CANNOT REACH YOUR GAS SUPPLIER, CALL THE FIRE DEPARTMENT.
  - DO NOT RETURN TO THE BUILDING UNTIL AUTHORIZED BY THE GAS SUPPLIER OR FIRE DEPARTMENT.
- SHOULD OVERHEATING OCCUR OR THE GAS SUPPLY FAIL TO SHUT OFF, TURN OFF THE MANUAL GAS CONTROL VALVE TO THE FURNACE.
- **CONSULT WITH THE LOCAL BUILDING DEPARTMENT AND FUEL GAS SUPPLIER BEFORE INSTALLING THE HEATER:**
  - THE INSTALLATION AND PURGING OF GAS PIPING MUST CONFORM TO LOCAL CODES, UTILITY COMPANY REQUIREMENTS, AND THE LATEST EDITION OF NATIONAL FUEL GAS CODE (NFGC) - ANSI Z223.1/NFPA 54, OR CSA B149.1, NATURAL GAS AND PROPANE INSTALLATION CODE.
  - LP FURNACES SHOULD NOT BE INSTALLED BELOW GRADE (IN A BASEMENT FOR EXAMPLE) IF SUCH INSTALLATION IS PROHIBITED BY FEDERAL, STATE, PROVINCIAL, AND/OR LOCAL LAWS, RULES, REGULATIONS, OR CUSTOMS.
  - INSTALLATION OF A GAS PRESSURE REGULATOR MAY BE REQUIRED IN THE GAS SUPPLY LINE. THE REGULATOR SHOULD NOT EXCEED THE MAXIMUM SUPPLY PRESSURE LISTED ON THE FURNACE RATING PLATE. DO NOT USE AN INDUSTRIAL-TYPE GAS REGULATOR.
  - FOLLOW ALL LOCAL CODES AND SECTION 8.3 OF NFGC WITH REGARD TO PURGING OF GAS PIPING TO ENSURE THAT THE AIR AND/OR FUEL GAS IN THE GAS PIPING IS PROPERLY VENTED TO A LOCATION WHERE AN EXPLOSIVE MIXTURE CANNOT ACCUMULATE.

## GAS PIPING

### ⚠ WARNING

**THIS FURNACE IS EQUIPPED AT THE FACTORY FOR USE ON NATURAL GAS ONLY. CONVERSION TO LP GAS REQUIRES A SPECIAL KIT IS AVAILABLE AT THE DISTRIBUTOR. FAILURE TO USE THE PROPER CONVERSION KIT CAN CAUSE FIRE, CARBON MONOXIDE POISONING, EXPLOSION, PROPERTY DAMAGE, PERSONAL INJURY OR DEATH. SEE THE CONVERSION KIT INDEX SUPPLIED WITH THE FURNACE. THIS INDEX IDENTIFIES THE PROPER LP GAS CONVERSION KIT REQUIRED FOR EACH PARTICULAR FURNACE.**

**IMPORTANT:** Any additions, changes or conversions required for the furnace to satisfactorily meet the application should be made by a qualified installer, service agency or the gas supplier, using factory-specified or approved parts.

**IMPORTANT:** Connect this furnace only to gas supplied by a commercial utility or commercial fuel provider.

**IMPORTANT:** U.L. or CSA recognized fuel gas and carbon monoxide (CO) detector(s) are recommended in all applications, and their installation should be in accordance with the manufacturer's recommendations and/or local laws, rules, regulations or customs.

Install the gas piping according to all local codes and regulations of the utility company.

If possible, run a separate gas supply line directly from the meter to the furnace. Conventional and alternate gas installations are detailed in Figure 30. Alternate gas from right of cabinet will require additional fittings. Two street elbows are recommended to route gas line behind the valve and align the knockout in the furnace casing. **NOTE: \*FOR Canadian installations only** corrugated stainless steel tubing (CSST) can be used for alternate gas routing inside the cabinet. A connection from CSST to solid black iron pipe must be made before exiting the cabinet. Ensure pipe passes through the grommet and the grommet seats properly in the cabinet side for proper furnace operation. Consult the local gas company for the location of the manual main shut-off valve. **The gas line and manual gas stop must be adequate in size to prevent undue pressure drop and never smaller than the pipe size to the gas valve on the furnace.** Refer to Table 11 for natural gas (Table 12 for LP gas) for the recommended gas pipe size. See Figure 30 for typical gas pipe connections.

**Install a ground joint union within 3 feet of the cabinet to easily remove the gas valve assembly. Local codes may dictate the location of the ground joint union. Install a manual shut-off valve in the gas line outside of the furnace casing and upstream of the ground joint union.** The manual shut-off valve should be readily accessible to turn the gas supply on or off. Install a drip leg in the gas supply line as close to the furnace as possible. Always use a pipe compound resistant to the action of liquefied petroleum gases on all threaded connections.

**FIGURE 30**  
GAS PIPING INSTALLATION

### UPFLOW

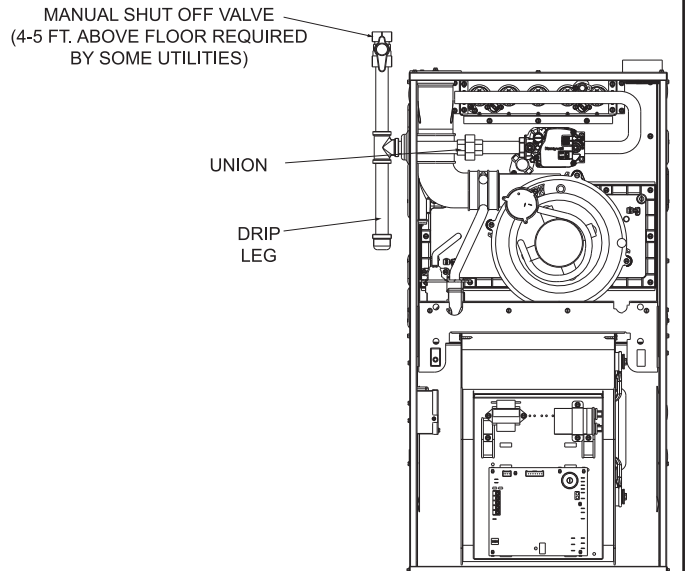

### CONVENTIONAL

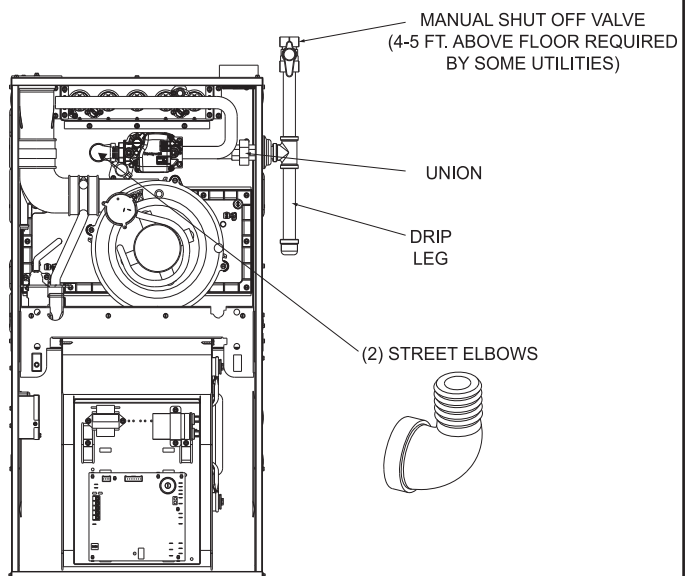

### ALTERNATE

ST-A1205-07-02

# GAS SUPPLY

## GAS PRESSURE

**IMPORTANT:** When making gas pipe connections, use a back-up wrench to prevent any twisting of the main gas valve and manifold. Do not overtighten gas valve on pipe.

Any strains on the gas valve can change the position of the gas orifices in the burners. This can cause erratic furnace operation.

**IMPORTANT:** Do not run a flexible gas connector inside the furnace. The gas pipe gasket in the cabinet does not seal around a flexible gas line.

If local codes allow the use of a flexible gas appliance connector, always use a new listed connector. Do not use a connector which has previously serviced another gas appliance. Massachusetts law requires that all flexible connectors be less than 36".

**It is important to have all openings in the cabinet burner compartment sealed for proper furnace operation.**

**IMPORTANT:** ENSURE that the furnace gas valve is not to be subjected to high gas line supply pressures.

DISCONNECT the furnace and its individual manual gas stop from the gas supply piping during **any pressure testing that exceeds 1/2 PSIG. (3.48 kPa).**

**Natural gas supply pressure must be 5" to 10.5" w.c. LP gas supply pressure must be 11" to 13" w.c. This pressure must be maintained with all other gas-fired appliances in operation.**

The minimum gas supply pressure to the gas valve for proper furnace input adjustments is 5" w.c. for natural gas, however 6" to 7" is recommended. The minimum gas supply pressure is 11" w.c. for LP gas.

### CAUTION

**ELEVATIONS ABOVE 2000 FT. REQUIRE THAT THE FURNACE INPUT RATING BE ADJUSTED AND THAT THE SIZE OF THE BURNER ORIFICES BE RECALCULATED BASED ON ELEVATION AND GAS HEATING VALUE. THE BURNER ORIFICES MAY (OR MAY NOT) NEED TO BE CHANGED. SEE THE SECTION TITLED "HIGH ALTITUDE INSTALLATIONS" OF THIS BOOK FOR INSTRUCTIONS.**

FIGURE 31

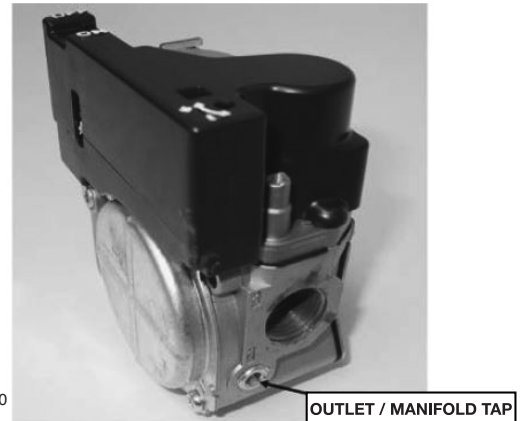

ST-A1194-88-00

FIGURE 32

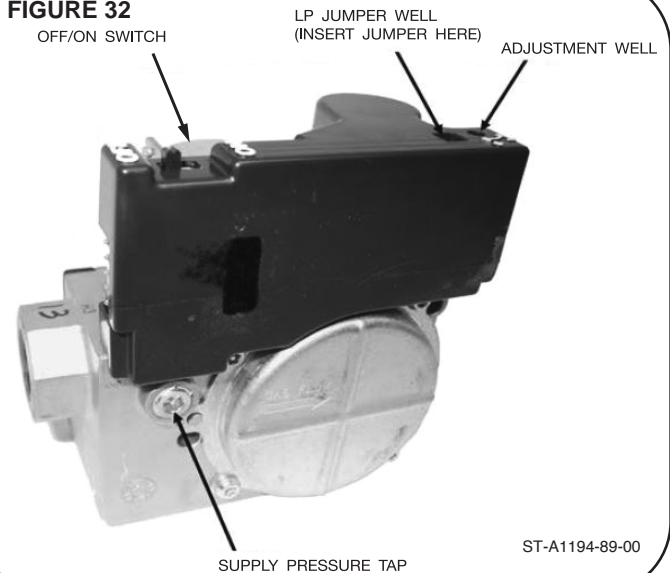

**TABLE 11**  
NATURAL GAS PIPE CAPACITY TABLE (CU. FT./HR.)

Capacity of gas pipe of different diameters and lengths in cu. ft. per hr. with pressure drop of 0.3 in. and specific gravity of 0.60 (natural gas).

Nominal Iron Pipe Size, Inches	Length of Pipe, Feet							
	10	20	30	40	50	60	70	80
1/2	132	92	73	63	56	50	46	43
3/4	278	190	152	130	115	105	96	90
1	520	350	285	245	215	195	180	170
1-1/4	1,050	730	590	500	440	400	370	350
1-1/2	1,600	1,100	890	760	670	610	560	530

After the length of pipe has been determined, select the pipe size which will provide the minimum cubic feet per hour required for the gas input rating of the furnace. By formula:

$$\text{Cu. Ft. Per Hr. Required} = \frac{\text{Gas Input of Furnace (BTU/HR)}}{\text{Heating Value of Gas (BTU/FT}^3\text{)}}$$

The gas input of the furnace is marked on the furnace rating plate. The heating value of the gas (BTU/FT<sup>3</sup>) may be determined by consulting the local natural gas utility or the LP gas supplier.

# LP CONVERSION

## **▲ WARNING**

**NEVER PURGE A GAS LINE INTO THE COMBUSTION CHAMBER. NEVER USE MATCHES, FLAME OR ANY IGNITION SOURCE FOR CHECKING LEAKAGE. FAILURE TO ADHERE TO THIS WARNING CAN CAUSE A FIRE OR EXPLOSION RESULTING IN PROPERTY DAMAGE, PERSONAL INJURY OR DEATH.**

**TO CHECK FOR GAS LEAKAGE, USE AN APPROVED CHLORIDE-FREE SOAP AND WATER SOLUTION, OR OTHER APPROVED METHOD.**

## **GAS VALVE**

This furnace has a 24-volt gas valve. It has ports for measuring supply and manifold gas pressure. The valve body contains a pressure regulator to maintain proper manifold gas pressure.

A control switch is on the valve body. It can be set to only the “ON” or “OFF” positions. The gas valve is a slow-opening valve. See Figure 32.

When energized, it takes 2 to 3 seconds to fully open.

## **▲ WARNING**

- 1. LP TANKS FROM LOCAL LP SUPPLIER MUST NOT BE USED TO STORE ANYTHING (SUCH AS FERTILIZER) EXCEPT LP GAS. THIS INCLUDES ALL DELIVERY VESSELS (LP TRUCKS). IF MATERIAL OTHER THAN LP GAS IS USED IN THE SAME VESSELS/TANK AS THE LP GAS, THE LP GAS CAN BECOME CONTAMINATED AND DAMAGE THE FURNACE. THIS WILL VOID THE MANUFACTURER’S WARRANTY. CONTACT THE SUPPLIER TO MAKE SURE FERTILIZER IS NOT USED IN THE SAME TANKS USED TO STORE AND DELIVER LP GAS.**

- 2. NOTE:** Order the correct LP conversion kit from the furnace manufacturer. Furnace conversion to LP gas must be performed by a qualified installer, service agency or the gas supplier.
- 3.** All 34” 90+ Modulating Gas Furnaces installed at high elevations above 5,000 ft. require the installation of a high altitude kit that includes a new model data card for proper operation.

**NOTE:** High altitude operation is limited to a maximum altitude of 8,000 ft.

All gas piping must comply with the latest NFPA 54 National Fuel Gas Code and all state and local codes. All electrical wiring must comply with the latest NFPA 70, National Electrical Code and all state and local codes.

Be sure to check the fuel code of your furnace. The fuel code is adjacent to the serial number. See the LP conversion kit index that came with your furnace to determine the correct LP conversion kit.

- 4.** All altitudes use a 1.10mm orifice. The unique 2% derate requirement per 1000 ft. allows the lower barometric pressure to meet this requirement.

**TABLE 12**  
**LP GAS PIPE CAPACITY TABLE (CU. FT./HR.)**

Maximum capacity of pipe in thousands of BTU per hour of undiluted liquefied petroleum gases (at 11 inches water column inlet pressure).  
(Based on a Pressure Drop of 0.5 Inch Water Column)

Nominal Iron Pipe Size, Inches	Length of Pipe, Feet											
	10	20	30	40	50	60	70	80	90	100	125	150
½	275	189	152	129	114	103	96	89	83	78	69	63
¾	567	393	315	267	237	217	196	182	173	162	146	132
1	1,071	732	590	504	448	409	378	346	322	307	275	252
1-¼	2,205	1,496	1,212	1,039	913	834	771	724	677	630	567	511
1-½	3,307	2,299	1,858	1,559	1,417	1,275	1,181	1,086	1,023	976	866	787
2	6,221	4,331	3,465	2,992	2,646	2,394	2,205	2,047	1,921	1,811	1,606	1,496

Example (LP): Input BTU requirement of unit, 120,000  
Equivalent length of pipe, 60 ft. = ¾” IPS required.



# LP CONVERSION

## ▲ WARNING

**TURN OFF ELECTRICAL POWER AND MAIN GAS SUPPLY BEFORE BEGINNING MODIFICATION. FAILURE TO DO SO CAN RESULT IN ELECTRICAL SHOCK OR EXPLOSION CAUSING PROPERTY DAMAGE, PERSONAL INJURY OR DEATH.**

## KIT INSTALLATION

1. Turn off power to unit and disconnect the gas line at the union ahead of the combination gas valve.
2. Remove the burner compartment access door.
3. Disconnect the wires from the gas valve and remove the screws that attach the manifold, and then remove from assembly.
4. Follow detailed instructions on "LP Conversion Kit" to convert the gas valve for LP (Figure is included). Convert the gas valve from natural gas to LP by removing the "NAT" sticker and applying the supplied jumper on the receptacle located beneath the label. Make sure that both prongs of receptacle engage the jumper.
5. Remove the burner orifices from the manifold and replace with the supplied LP orifices.
6. **NOTE:** To convert the stepper-controlled modulating gas valve, a jumper is required to connect the two pins inside the jumper well. It is possible to install the jumper such that the pins are not connected. This is incorrect. The jumper must connect the pins together inside the jumper well. This can be confirmed by visual inspection and by verifying proper manifold pressure at high fire (100%) after the jumper is installed. Manifold pressure should always be checked when converting the furnace for LP operation. Figures 33 and 34 below show the correct way and the incorrect way to install the jumper. The jumper well is located next to the adjustment well (with "+" and "-" text and two-headed arrow) and will be covered by a sticker or label. To convert to LP the label over the jumper well will need to be removed.

**FIGURE 33**  
LP JUMPER INSTALLED ON SERVO MODULATING GAS VALVE WITH PINS PROPERLY CONNECTED. THIS IS CORRECT. MAKE SURE THAT THE JUMPER CONNECTS THE TWO PINS TOGETHER AND VERIFY MANIFOLD GAS PRESSURE AT HIGH FIRE TO MAKE SURE THAT THE VALVE IS PROPERLY CONVERTED FOR LP GAS.

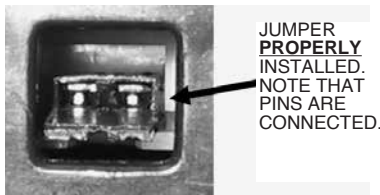

**FIGURE 34**

LP JUMPER INSTALLED ON SERVO MODULATING GAS VALVE WITH PINS NOT CONNECTED. THIS IS INCORRECT. MAKE SURE THAT THE JUMPER CONNECTS THE TWO PINS TOGETHER AND VERIFY MANIFOLD GAS PRESSURE AT HIGH FIRE TO MAKE SURE THE VALVE IS PROPERLY CONVERTED FOR LP GAS.

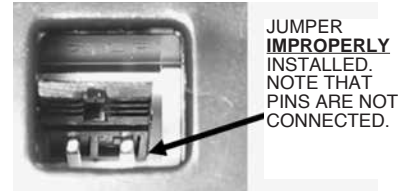

**DO NOT REMOVE OR DEFACE ORIGINAL RATING PLATE.**

For US and Canada L.P. Gas Orifice Drill Size  
(2% Per 1000ft. De-Rate)  
90+ Burner input (per burner)  
14,000 @ sea level

Altitude	Input per burner avg.	Orifice size
0 to 2000ft	14000	1.10mm
2001 to 3000ft	13440	
3001 to 4000ft	13160	
4001 to 5000ft	12880	
5001 to 6000ft	12600	
6001 to 7000ft	12320	
7001 to 8000ft	12040	

**FIGURE 35**

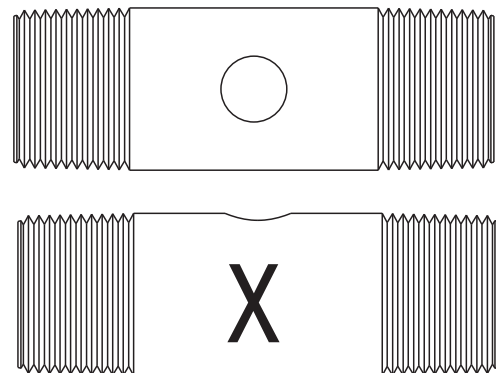

ST-A1195-84

# LP CONVERSION

**NOTE:** 1.10 mm orifices provided in kit are used in all altitudes. These orifices comply with the 2% de-rate requirements due to the natural de-rate related to lower barometric pressure.

**NOTE:** Use a pipe compound resistant to the action of the liquefied petroleum gases at all threaded pipe connections.

7. Reinstall the manifold assembly by reversing the removal process.
8. Plug the wires into the gas valve.
9. Install the tapped gas nipple supplied with the kit into the inlet of the gas valve. Be sure to apply pipe dope or Teflon tape. After tightening the gas nipple, the tapped hole in the nipple should be in the horizontal position. See **Figure 35**.
10. Install the Inlet Pressure Switch into the tapped hole. Be sure to apply pipe dope or Teflon tape. After tightening, the terminals on the Inlet Pressure Switch should be facing down towards the blower shelf. See **Figure 36**.
11. Remove the connection in the white wire going to the gas valve. Plug the ¼" female terminal from the gas valve onto the terminal on the Inlet Pressure Switch. Using the supplied jumper wire, connect the remaining ¼" male terminal on the white wire to the Inlet Pressure Switch. See **Figure 37**.
12. Reconnect the supply gas line to the furnace.
13. Turn on gas supply and electrical supply.
14. Check unit thoroughly for gas leaks – with soap and water – not with a flame.
15. Follow lighting instructions to put furnace into operation.
16. Operate thermostat to check unit operation for ignition and extinction characteristics.
17. **Manifold gas pressure must be adjusted to 10" W.C. after valve conversion to LP gas with furnace in operation and proper gas supply pressure (see rating plate). The gas supply line pressure should be between 11" and 14" W.C. at the appliance.**
18. **NOTE:** The igniter wire must not be routed any closer than 1" from the gas valve. Otherwise, noise from the spark igniter wire could reset the valve during ignition trial resulting in loss of heat.

## COMPLETING CONVERSION

1. Using a ballpoint indelible pen, record the following information on label 92-18153-05 provided in this kit.
  - a. Date of conversion.
  - b. Installer's name, address and telephone number.
  - c. Burner orifice size.
2. Place completed conversion label next to the rating plate.
3. Install the burner compartment access door.

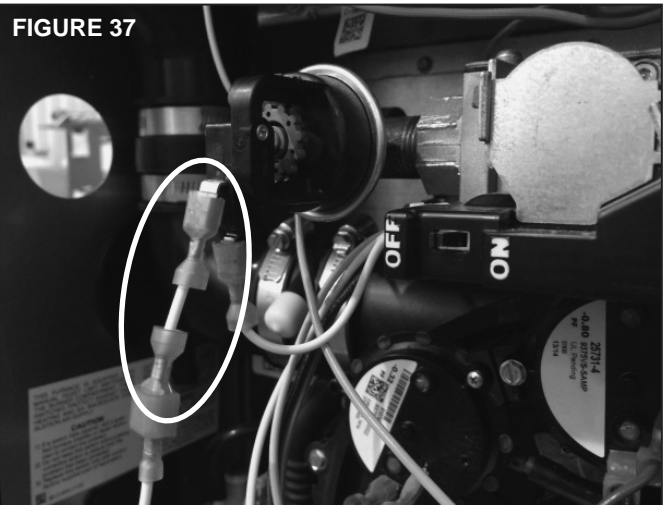
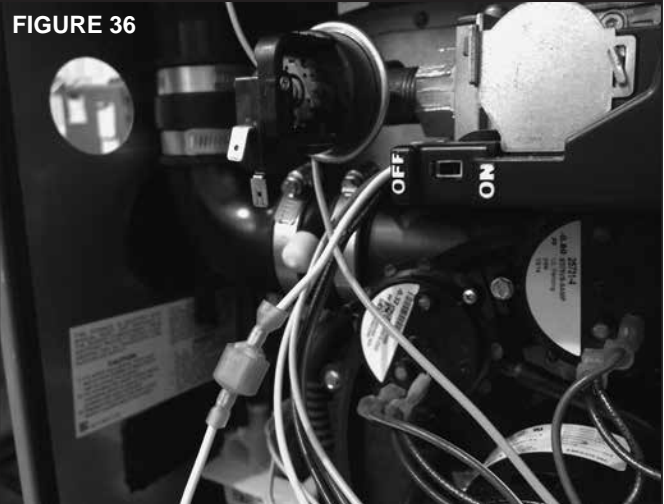

**FIGURE 38**  
TYPICAL LP KIT CONTENTS

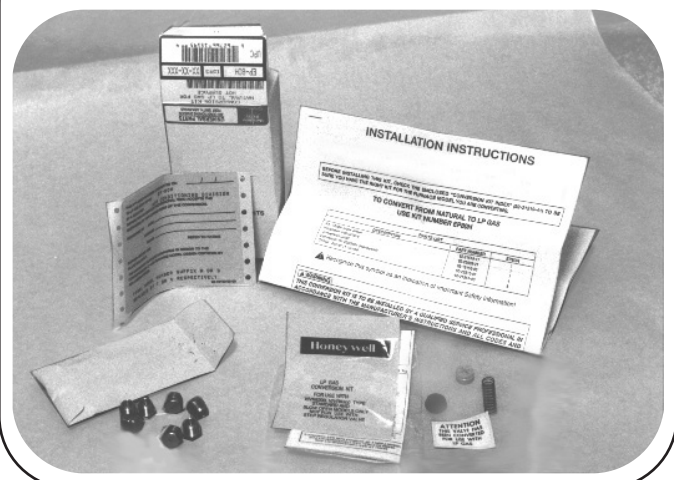

# FURNACE ADJUSTMENTS

The following pages will cover in detail how to select the proper orifice, adjust the manifold pressures (at min and max firing rates), verify the rate and set the proper temperature rise. It is very important to ensure the unit is operating within the design parameters to deliver the proper amount of heat when considering local gas heating values, altitudes of installation and manifold pressures.

The 98% Modulating products require a 2% reduction in rate (input capacity in BTU's) per each 1000 ft of elevation above sea level when installed at elevations of 2,000 ft or more. For example; a -98V furnace installed at 5,000 ft above sea level would need to have the input rate reduced to 10% less than the input BTU's listed on the nameplate.

The process of properly adjusting the furnace requires five steps:

1. Orifice Selection/Altitude Adjustment
2. Adjust The Gas Pressures (Inlet and Outlet, high and low fire)
3. Verify the Input Rate
4. Adjust the Gas Heat Temperature Rise
5. Temperature Rise Verification

These steps may need to be repeated (in the same order) to achieve the proper final adjustments required. Below is the suggested procedure to select, adjust and verify furnace operation.

## STEP 1: ORIFICE SELECTION/ ALTITUDE ADJUSTMENT

The furnace is supplied with # 51 orifices from the factory that will deliver nameplate input with natural gas with a heating value of 1100 BTU's/ft<sup>3</sup> at elevations from 0-2,000

ft. All other elevations and heating values will require changing orifices and possibly input rate.

- A. Gas requirements: LP or Natural?

The furnace is supplied configured for Natural Gas. If installation will require LP gas, then an LP conversion kit is required (See Section of this manual titled **LP Conversion** for more details).

- B. Obtain the average annual sea-level corrected heating value (for orifice calculations) and average annual altitude-adjusted heating value (for rate calculation) from your local gas supplier.

### High Altitude Input Correction and Conversions

- C. If the elevation of your installation is below 2,000 ft, skip this step. If the elevation of your installation is 2,000 ft or more above sea level, correct your input rate based on the altitude. The formula for determining the new input rate based on altitude is as follows:

$$\text{New Input} = \text{Nameplate Input} \times (1 - ((\text{Elevation in Ft}/1000\text{Ft}) \times 0.02))$$

### Select a High Altitude Kit

If the furnace is installed at an elevation of 5,000 ft. to 8000 ft. above sea-level, a high-altitude conversion must be made to the furnace. Kits can be ordered from the distributor. Use the table below to select your kit. Instructions for the conversion are included with the kit.

- D. Select Orifice

Use Table 14 to select the proper natural gas orifice based on the local heating rate and the elevation (when above 2,000 ft). Note: LP conversion kit contains 1.10mm orifices that are correct for all altitudes up to 8000 ft.

**TABLE 13**  
HIGH ALTITUDE KITS

MODEL INPUT	NAMEPLATE INPUT (BTU)	KIT NO.	Min. Alt. kit required	Max. Alt. kit applies	Model Data Card	Data Card Conversion label
60k	56K	RXGY-F53	5000 ft elevation	8000 ft elevation	47-105682-11	92-105683-01
70k	70K	RXGY-F54	5000 ft elevation	8000 ft elevation	47-105682-12	92-105682-02
85k	84K	RXGY-F55	5000 ft elevation	8000 ft elevation	47-105682-13	92-105683-03
100k	98K	RXGY-F56	5000 ft elevation	8000 ft elevation	47-105682-14	92-105683-04
115k	112K	RXGY-F57	5000 ft elevation	8000 ft elevation	47-105682-15	92-105683-05

Note: Above 5,000 ft., the last 2 elbows on an alternate horizontal termination which are on the exterior of the building will be counted in the maximum vent length and maximum number of elbows permitted.

# FURNACE ADJUSTMENTS

## LP GAS ORIFICE SELECTION

For LP Orifice selection, refer to the “LP Conversion” section of this manual.

### E. Order Orifices:

If a change in orifice size is required, they can be ordered from the local distributor. Orifice sizes are selected by adding the 2-digit drill size required in the orifice part number. Drill sizes available are 39 through 64. Metric sizes are available in 1.10mm (-90):

To order an orifice, use this format: Part number = 62-22175-(drill size)

Example 1:

#60 drill size orifice required  
Select Part # 62-22175-60

Example 2:

1.10 mm drill size orifice required  
Select Part # 62-22175-90

## STEP 2: ADJUSTING THE GAS PRESSURES

*The maximum gas supply pressure to the furnace must not exceed 10.5” w.c. natural gas, or 13” w.c. LP gas.* The minimum supply gas pressure to the gas valve should be 5” w.c. natural gas or 11” w.c. LP gas. A

properly calibrated manometer is required for accurate gas pressure measurements.

If the supply gas line pressure is above these ranges, install an in-line gas regulator to the furnace for natural gas units. With LP gas, have the LP supplier reduce the line pressure at the regulator.

If supply gas line pressure is below these ranges, either remove any restrictions in the gas supply piping or enlarge the gas pipe. See Tables 11 and 12 in Gas Supply section of this manual. With LP gas, have the LP supplier adjust the line pressure at the regulator.

### ▲ CAUTION

**ELEVATIONS ABOVE 2000 FT. REQUIRE THAT THE FURNACE INPUT RATING BE ADJUSTED AND THAT THE SIZE OF THE BURNER ORIFICES BE RECALCULATED BASED ON ELEVATION AND GAS HEATING VALUE. THE BURNER ORIFICES MAY (OR MAY NOT) NEED TO BE CHANGED.**

## SUPPLY GAS PRESSURE MEASUREMENT

1. With gas shut off to the furnace at the manual gas valve outside the unit, remove the line pressure tap plug on the gas valve. See Figure 40.

**TABLE 14**  
NATURAL GAS ORIFICE SELECTION BASED ON HEATING VALUE AND ELEVATION (FOR U.S. & CANADA.)

Grey Cells Indicate Factory Orifice Size	Sea Level Heating Value	ELEVATION						
		Sea Level to 2,000'	2,001' to 3,000'	3,001' to 4,000'	4,001' to 5,000'	5,001' to 6,000'	6,001' to 7,000'	7,001' to 8,000'
1,000- 1,100	1100	51	51	51	50	50	50	50
	1050	50	50	50	50	50	50	50
	1000	50	50	50	49	49	49	49
900-999	999	50	50	50	49	49	49	49
	950	49	49	49	49	49	49	49
	900	49	48	48	48	48	48	48
800-899	899	49	48	48	48	48	48	48
	850	48	48	48	47	47	47	47
	800	47	47	47	46	46	46	46
700-799	799	47	47	47	46	46	46	46
	750	46	46	46	46	46	46	45
	700	44	44	44	44	44	48	49
Rate per orifice (BTU's/HR) =		14,000	13,440	13,160	12,880	12,600	12,320	12,040

\*Chart is based on Natural Gas with a specific gravity of 0.60

\*\*Be sure to use sea level heating value. When requesting the heating value from a local utility, it must be converted to sea level equivalent in order to use this table.

# FURNACE ADJUSTMENTS

2. Connect a manometer to the pressure tap.
3. Turn on the gas supply and operate the furnace at 100% and all other gas-fired units on the same gas line as the furnace.
4. Note or adjust the supply-line pressure to give:
  - A. 5" - 10.5" w.c. for natural gas.
  - B. 11" - 13" w.c. for LP gas.
 If your gas supply does not fall within these ranges, contact your gas supplier to correct.
5. Shut off the gas at the manual gas valve and remove the manometer.
6. Replace the supply-line pressure tap plug before turning on the gas.
7. Check unit for leaks using an approved leak detector. Do **NOT** use a flame of any kind.

FIGURE 39

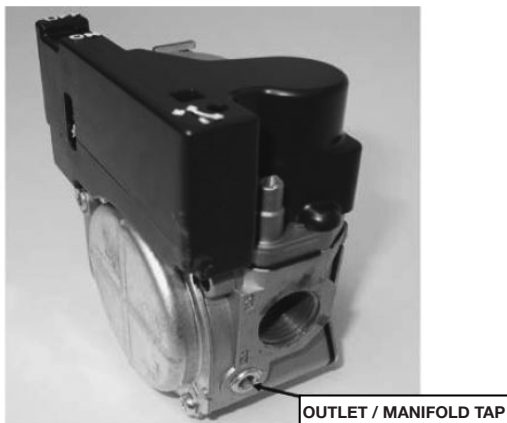

ST-A1194-88-00

OUTLET / MANIFOLD TAP

FIGURE 40

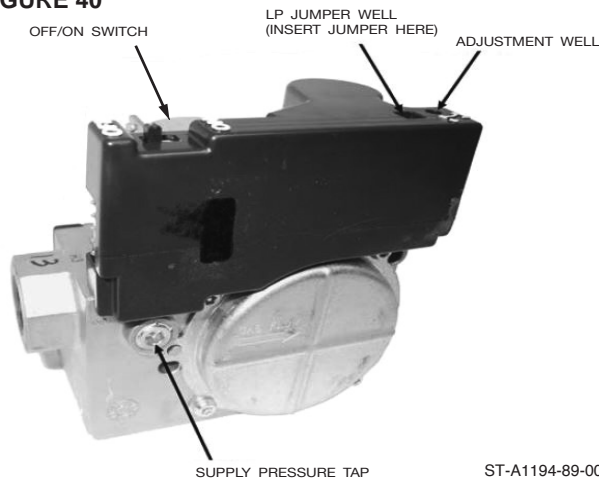

SUPPLY PRESSURE TAP

ST-A1194-89-00

FIGURE 41  
SERVO CONTROLLED GAS VALVE PRESSURE ADJUSTMENT

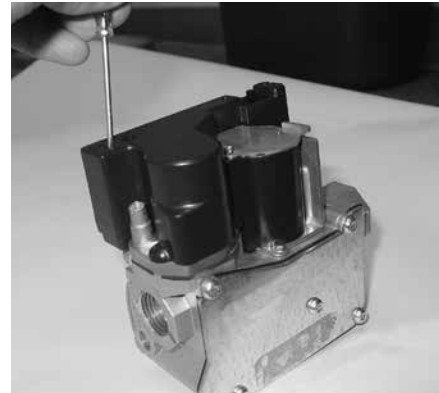

**NOTE:** The adjustment wheel will not stop rotating when it hits the maximum or minimum position. Instead, it will continue to rotate to the opposite adjustment. Use the letters on the wheel as a guide.

## OUTLET/MANIFOLD GAS PRESSURE MEASUREMENT/ADJUSTMENT

Rate adjustment is a combination of selecting the correct orifices based on heating value and altitude

The outlet/manifold pressure on this modulation furnace is capable of being adjusted at the maximum firing rate and at the minimum firing rate using the same adjustment wheel shown in Figure 41. **Note: Do not attempt to adjust the outlet/manifold pressure at intermediate inputs.**

## ADJUST MANIFOLD PRESSURE AT MAXIMUM FIRING RATE

**NOTE: HIGH FIRE MUST BE ADJUSTED BEFORE LOW FIRE**

1. Disconnect electrical power to the furnace.
2. Remove all thermostat connections and jumper R to W1.
3. Turn gas manual shut-off valve located outside the furnace to the CLOSED position.
4. **IMPORTANT:** Be sure that the gas manual shut-off valve located outside the furnace has been in the CLOSED position for at least five minutes. Remove the outlet/manifold pressure tap plug in the gas valve. See Figure 39.
5. Install field supplied pressure tap to the outlet/manifold tap. Connect the positive pressure hose from a manometer to the pressure tap.
6. Set dip switch SW10 to the "OFF" position and dip-switch SW11 to the "ON" position (this will force the furnace to operate at the maximum firing rate (100% only).
7. Replace the blower compartment door.
8. Turn gas manual shut-off valve located outside the furnace to the OPEN position.
9. Connect furnace electrical power supply.

# FURNACE ADJUSTMENTS

10. After ignition, allow furnace to operate and complete the pressure switch calibration before checking maximum firing rate outlet/manifold pressure.

**Note:** The manifold gas pressure to be:  
3.5" w.c. ( $\pm 3$ ) for natural gas.  
10.0" w.c. ( $\pm 5$ ) for LP gas.

11. To adjust the outlet/manifold pressure, insert a small slotted screwdriver into the opening at the top of the valve. See Figure 41.

The adjustment wheel is shipped from the factory in the nominal position (noted as position A on the Wheel). The wheel can be adjusted four full revolutions (or 64 clicks) clockwise to increase manifold pressure or four revolutions (or 64 clicks) counter-clockwise to decrease the manifold pressure. Each click is a very minimal adjustment and several clicks may be required to adjust the manifold pressure to the necessary 3.5"wc (natural gas) or 10.0"wc (LP) for high fire. The installer must wait 3 seconds following a click before progressing to the next click. Verify the new manifold pressure following each adjustment. Adjusting the valve too quickly will cause the valve to stop responding. If this happens turn the adjustment wheel back to where the wheel stopped responding and begin adjusting again. For example, if the adjustment resulted in 3 rapid clicks, turn the adjustment wheel back 3 clicks. You may also disconnect electrical power to the furnace for 30 seconds then connect furnace electrical power to regain adjustment.

Use the marking on the wheel as a guide. The adjustment wheel will not stop rotating when the valve's outlet pressure reaches its maximum or minimum value. Instead, the wheel can be rotated further but no further adjustment to the outlet pressure will be made.

Once the maximum adjustment (high or low) is reached, the wheel can be turned in the opposite direction and this will cause the pressure to also move in the opposite direction. The first click in the opposite direction will cause a pressure change in the opposite direction even if the maximum adjustment in the original direction has been exceeded by several clicks.

If power to the furnace (and therefore the gas valve) has been interrupted and the adjustment wheel turned while power is off, the outlet pressure of the valve will not be adjusted and will remain the same and will be re-assigned to the new wheel selection.

12. Repeat steps 10 and 11 if necessary.
13. Once high fire manifold pressure has been adjusted, slide the gas valve ON/OFF switch to the OFF position. Allow the indoor blower to complete off delay.
14. Disconnect electrical power to furnace. Remove blower door.
15. Slide the gas valve ON/OFF switch to the ON position.

## ADJUST MANIFOLD PRESSURE AT MINIMUM FIRING RATE

1. Set dip switch SW10 to the "ON" position and dip-switch SW11 to the "OFF" position (this will force the furnace to operate at the minimum firing rate (40%) only).
2. Replace the blower compartment door.
3. Connect furnace electrical power supply.
4. After ignition, allow furnace to operate and complete the pressure switch calibration before checking minimum firing rate outlet/manifold pressure.

**Note:** The manifold gas pressure to be:

A. 0.56" w.c. ( $\pm 1$ ) for natural gas.

B. 1.60" w.c. ( $\pm 2$ ) for LP gas.

5. To adjust the outlet/manifold pressure, insert a small slotted screwdriver into the opening at the top of the valve (see Figure 41.)

The adjustment wheel is shipped from the factory in the nominal position (noted as position A on the Wheel). The wheel can be adjusted four full revolutions (or 64 clicks) clockwise to increase manifold pressure or four revolutions (or 64 clicks) counter-clockwise to decrease the manifold pressure. Each click is a very minimal adjustment and several clicks may be required to adjust the manifold pressure to the necessary 0.56"wc (natural gas) or 1.60"wc (LP) for low fire. Recommend using a digital manometer capable of reading to 3 decimal places. Each click adjustment at minimum firing rate can result in manifold pressure change of .100". The installer must wait 3 seconds following a click before progressing to the next click. Verify the new manifold pressure following each adjustment. Adjusting the valve too quickly will cause the valve to stop responding. If this happens turn the adjustment wheel back to where the wheel stopped responding and begin adjusting again. For example, if the adjustment resulted in 3 rapid clicks, turn the adjustment wheel back 3 clicks. You may also disconnect electrical power to the furnace for 30 seconds then connect furnace electrical power to regain adjustment.

Use the marking on the wheel as a guide. The adjustment wheel will not stop rotating when the valve's outlet pressure reaches its maximum or minimum value. Instead, the wheel can be rotated further but no further adjustment to the outlet pressure will be made.

Once the maximum adjustment (high or low) is reached, the wheel can be turned in the opposite direction and this will cause the pressure to also move in the opposite direction. The first click in the opposite direction will cause a pressure change in the opposite direction even if the maximum adjustment in the original direction has been exceeded by several clicks.

If power to the furnace (and therefore the gas valve) has been interrupted and the adjustment wheel turned

# FURNACE ADJUSTMENTS

while power is off, the outlet pressure of the valve will not be adjusted and will remain the same and will be re-assigned to the new wheel selection.

6. Repeat steps 4 and 5 if necessary.
7. Once low fire manifold pressure has been adjusted, slide the gas valve ON/OFF switch to the OFF position. Allow the indoor blower to complete off delay.
8. Disconnect electrical power to furnace. Remove blower door.
9. Remove jumper across R and W1 to remove heat call.
10. Re-connect thermostat wires. There should be no call for heat present at the thermostat.
11. Turn gas manual shut-off valve located outside the furnace to the CLOSED position.
12. Remove manifold pressure tap. Replace and tighten manifold tap plug.
13. Slide gas valve ON/OFF switch to the ON position.
14. Turn gas manual shut-off valve to the OPEN position. Check for gas leaks using an approved leak detector. Do NOT use a flame of any kind to check for leaks. Repair any leaks before continuing with furnace adjustments.

## STEP 3: VERIFY THE INPUT RATE

Once the orifices have been selected and the manifold pressure set, the input rate of the furnace can be determined by clocking the amount of time it takes for your meter to make one revolution. Table 15 specifies the number of cubic feet per hour based on the number of seconds measured for one revolution of the meter (meters listed are; (a) one cubic meter per revolution and (b) ten cubic meters per revolution).

Once you have determined the number of cubic feet per revolution, the input rate of the furnace can then be determined using the following formula:

$$\text{Input Rate} = ((\text{Gas Rate (ft}^3/\text{Hour)}) \times (\text{Altitude-Adjusted Gas Heating Value (BTU's/ft}^3)))$$

Note the units which cancel:

$$\text{Input Rate} = (\text{Gas Rate (ft}^3/\text{Hour)}) \times (\text{Altitude-Adjusted Gas Heating Value (BTU's/ft}^3))$$

### Example:

The following information is determined:

1. Altitude-Adjusted Gas Heating Value = 975 BTU/ft<sup>3</sup> (given from gas supplier).
2. Meter used is 1 revolution per ft<sup>3</sup>.
3. Time per revolution at high fire = 36 seconds (this is measured by the installer).
4. The formula for Gas Rate is as follows:

$$\text{Gas Rate (ft}^3/\text{hr) with 1ft}^3/\text{Rev Meter} = (3600)/(\text{Revolution Time (in seconds)})$$

$$\text{Gas Rate (ft}^3/\text{hr) with 1ft}^3/\text{Rev Meter} = (3600)/(36 \text{ Seconds})$$

$$\text{Gas Rate} = 100 \text{ ft}^3/\text{Hour}$$

(Note this value could have also been taken directly from Table 15).

$$\text{Input Rate} = ((\text{Gas Rate (ft}^3/\text{Hour)}) \times (\text{Altitude-Adjusted Gas Heating Value (BTU's/ft}^3)))$$

Fill in the values:

$$\text{Input Rate} = ((100\text{ft}^3/\text{Hour}) \times (975 \text{ BTU's/ft}^3))$$

$$\text{Input Rate} = 97,500 \text{ BTU's/Hour}$$

If the rate calculated does not match the furnace input on the rating label (below 2,000 ft) or the elevation-corrected rate calculated in item of above (**Selecting the Orifices**) (at or above 2,000 ft in elevation) within +/-5%, the next larger orifice (if rate is too low) or the next smaller orifice (if the rate is too high) must be installed and the process repeated from (Adjusting the Gas Pressures).

**Repeat steps 2 and 3 until the proper rate is achieved with the manifold pressure within the tolerances specified herein.** When both of these adjustments are correct, proceed to [Step 4, Adjusting Gas Heat Temperature Rise](#).

To determine the gas flow rate, calculate the cubic ft per hour use the following formulas or use the following table:

$$\text{Gas Rate (ft}^3/\text{hr) w 1ft}^3/\text{Rev Meter} = (3600)/(\text{Revolution Time (in seconds)})$$

$$\text{Gas Rate (ft}^3/\text{hr) w 2ft}^3/\text{Rev Meter} = (7200)/(\text{Revolution Time (in seconds)})$$

$$\text{Gas Rate (ft}^3/\text{hr) w 5ft}^3/\text{Rev Meter} = (18000)/(\text{Revolution Time (in seconds)})$$

# FURNACE ADJUSTMENTS

**TABLE 15**  
GAS RATE (FT<sup>3</sup>/HOUR)

Seconds Per Revolution	Meter			Seconds Per Revolution	Meter		
	1 ft <sup>3</sup> /Rev	2 ft <sup>3</sup> /Rev	5 ft <sup>3</sup> /Rev		1 ft <sup>3</sup> /Rev	2 ft <sup>3</sup> /Rev	5 ft <sup>3</sup> /Rev
24	150	300	750	73	49	99	247
25	144	288	720	74	49	97	243
26	138	277	692	75	48	96	240
27	133	267	667	76	47	95	237
28	129	257	643	77	47	94	234
29	124	248	621	78	46	92	231
30	120	240	600	79	46	91	228
31	116	232	581	80	45	90	225
32	113	225	563	81	44	89	222
33	109	218	545	82	44	88	220
34	106	212	529	83	43	87	217
35	103	206	514	84	43	86	214
36	100	200	500	85	42	85	212
37	97	195	486	86	42	84	209
38	95	189	474	87	41	83	207
39	92	185	462	88	41	82	205
40	90	180	450	89	40	81	202
41	88	176	439	90	40	80	200
42	86	171	429	91	40	79	198
43	84	167	419	92	39	78	196
44	82	164	409	93	39	77	194
45	80	160	400	94	38	77	191
46	78	157	391	95	38	76	189
47	77	153	383	96	38	75	188
48	75	150	375	97	37	74	186
49	73	147	367	98	37	73	184
50	72	144	360	99	36	73	182
51	71	141	353	100	36	72	180
52	69	138	346	101	36	71	178
53	68	136	340	102	35	71	176
54	67	133	333	103	35	70	175
55	65	131	327	104	35	69	173
56	64	129	321	105	34	69	171
57	63	126	316	106	34	68	170
58	62	124	310	107	34	67	168
59	61	122	305	108	33	67	167
60	60	120	300	109	33	66	165
61	59	118	295	110	33	65	164
62	58	116	290	111	32	65	162
63	57	114	286	112	32	64	161
64	56	113	281	113	32	64	159
65	55	111	277	114	32	63	158
66	55	109	273	115	31	63	157
67	54	107	269	116	31	62	155
68	53	106	265	117	31	62	154
69	52	104	261	118	31	61	153
70	51	103	257	119	30	61	151
71	51	101	254	120	30	60	150
72	50	100	250	121	30	60	149

## STEP 4: ADJUST GAS HEAT TEMPERATURE RISE

### COMFORT/EFFICIENCY SELECT:

One dipswitch SW18 is provided to allow for selection between Comfort and Efficiency mode as follows:

SW18 = OFF = Efficiency Mode, Target Temp Rise = mid-rise as specified on Nameplate Label.

SW18 = ON = Comfort Mode, Target Temp Rise = +4°F above Nameplate mid-rise.

Further, for communicating systems, the above selection (made with dipswitch SW18 in legacy mode) can be made via the Econet control center.

### GAS HEAT RISE AIRFLOW ADJUSTMENTS:

Four dipswitches are provided to adjust the low and high heating temperature rise by changing the airflow.

The switches are 13, 14, 15 and 16 and are labelled in pair "LOW ADJ" and "HI ADJ" on the IFC. Refer to the section titled "Integrated Furnace Control" for more information.

### CAUTION

IT IS IMPORTANT THAT EACH DUCT SYSTEM BE SIZED AND INSTALLED FOR THE SPECIFIC APPLICATION BY PROPERLY APPLYING THE APPROPRIATE INDUSTRY-ACCEPTED STANDARD. IF LESS THAN MINIMUM STANDARDS ARE APPLIED, THE EQUIPMENT USER COULD EXPECT TO EXPERIENCE HIGHER UTILITY BILLS, MAJOR COMPONENT FAILURE, VARYING DEGREES OF AIR NOISE OR OTHER UNSATISFACTORY ISSUES, OVER WHICH THE MANUFACTURER HAS NO CONTROL.

## STEP 5: TEMPERATURE RISE VERIFICATION AIRFLOW

The importance of proper airflow over the heat exchanger cannot be over-emphasized.

**NOTE:** Where the maximum airflow is expected to be over 1800 CFM, **BOTH** sides or the bottom must be used for return air.

### TEMPERATURE RISE CHECK:

To determine if the airflow is correct, make a temperature rise check.

1. Insert a thermometer in the supply air duct as close to the furnace as possible yet out of a direct line-of-site from the heat exchanger. See Figure 42.
2. Insert a thermometer in the return air duct as close to the furnace as possible.



# FURNACE ADJUSTMENTS

- Operate the furnace for a minimum of 15 minutes in the gas heat mode at the 100% (max) rate.
- When the thermometer in the supply air duct stops rising (approximately 5 minutes), subtract the return air temperature from the supply air temperature. The difference is the temperature rise.
- Compare the measured temperature rise to the approved temperature rise range listed on the furnace nameplate. See Figure 43.
- If the measured temperature rise is below the nameplate range, the gas input rate may need to be adjusted or the airflow may be too high. If the gas input is correct, select the next lowest speed tap for the heating function. If the measured temperature rise is above the nameplate range, the gas input rate may need to be adjusted or the duct system may be too restrictive due to undersized ducts. An undersized return duct is a common cause of an overly restrictive duct system.
- Repeat this procedure for low-fire (40% rate).

## ▲ WARNING

**THE MEASURED TEMPERATURE RISE MUST BE WITHIN THE TEMPERATURE RISE RANGE SPECIFIED ON THE RATING PLATE. OPERATING THE UNIT WITH A RISE OUTSIDE THE STATED RANGE COULD CAUSE DAMAGE TO THE HEAT EXCHANGER OR INTERMITTENT OPERATION.**

**THIS COULD CAUSE INJURY OR DEATH AND WILL VOID THE MANUFACTURER'S WARRANTY FOR THIS PRODUCT.**

**FIGURE 42**  
TEMPERATURE RISE MEASUREMENT

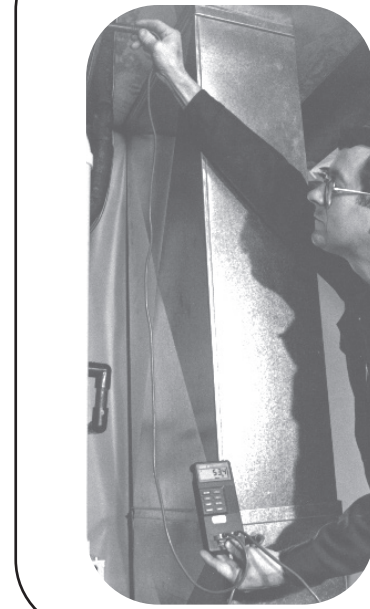

**FIGURE 43**  
TYPICAL FURNACE NAME PLATE

RHEEM SALES COMPANY, INC. FORT SMITH, ARKANSAS		CANADIAN ENERGY PERFORMANCE VERIFIED RENDIMENT ENERGETIQUE VERIFIE
		
MODEL NO./NUMERO DE MODELE: R98VA07M317USA SERIAL NO./ NUMERO DE SERIE: W0000100001		MFG. DATE <u>SEE DATE NOTE</u>
CATEGORY IV FORCED AIR FURNACE WHEN USING INDOOR AIR FOR COMBUSTION CONTROL SYSTEM JC CATEGORY IV TYP FSP DIRECT VENT FORCED AIR FURNACE WHEN USING OUTDOOR AIR FOR COMBUSTION. FOR INDOOR INSTALLATION ONLY, IN A BUILDING CONSTRUCTED ON-SITE. CATEGORIE IV GENERATEUR D'AIR CHAUD A AIR FORCEE LORSQUE DE L'AIR INTERIEUR EST EMPLOYE POUR LA COMBUSTION. CATEGORIE IV TYPE FSP EVACUATION DIRECTE GENERATEUR D'AIR CHAUD A AIR FORCEE LORSQUE DE L'AIR EXTERIEUR EST EMPLOYE POUR LA COMBUSTION. POUR INSTALLATION A L'INTERIEUR SEULEMENT, DANS UN BATIMENT CONSTRUIT SUR LE SITE.		
ELECTRIC 115 V. 60 HZ. 1 PH. MIN. CIRCUIT AMPACITY _____ AMPS. IB MOTOR FLA _____ ID MOTOR FLA _____ ELECTRIQUE 115V. 60 HZ 1 PH. COURANT MINIMAL ADMISSIBLE DE CIRCUIT _____ A. INTENSITE MAXIMAL DE _____ MOTEUR DE SOUFFLANTE INTERIEURE ET _____ MOTEUR DE TIRANGE INDIUT. MAXIMUM OVERCURRENT PROTECTION DEVICE _____ AMPERES. DISPOSITIF DE PROTECTION CONTRE UNE SURINTENSITE DE _____ A AU MAXIMUM. NOx EMISSION LIMIT (NANOGRAMS/JOULE) _____ LIMITE D'EMISSION D'OXYDES D'AZOTE (NOx) EN NANORAMMES PAR JOULE _____		
HOURLY INPUT RATING DEBIT CALORIFIQUE MAXIMUM Btu/hr (Kw) _____ 75,000 (21.96)	HOURLY INPUT RATING DEBIT CALORIFIQUE MINIMUM Btu/hr (Kw) _____	FACTORY EQUIPPED FOR AGENCE A L'USINE POUR FOR GAS / GAZ NATURAL / NATUREL
IN THE U.S. AND CANADA, AT ELEVATIONS ABOVE 2,000 FT. (610M), DERATE THE INPUT 2% PER 1,000 FT. (305M) ABOVE SEA LEVEL. REFER TO INSTALLATION INSTRUCTIONS FOR PROPER ALTITUDE ADJUSTMENT. AUX ETATS-UNIS ET AU CANADA, A DES ALTITUDES SUPERIEURES A 610M(2,000PI), IL FAUT APPLIQUER UNE PUERTE DE 2% PAR TRANCHE DE 305M(1,000PI) AU-DESSUS DU NIVEAU DE LA MER. SE REPORTER AUX INSTRUCTIONS DE MONTAGE POUR PROCEDER AUX REGLAGES DUS A L'ALTITUDE.		
ORIFICE / INJECTEUR 51 DMS LIMIT SETTING / LIMITE COUPE-CIRCUIT 120° (49°) °F(°C) AUXILIARY LIMIT SETTING/ LIMITE COUPE-CIRCUIT COUPE-CIRCUIT AUXILIAIRE °F(°C)		NATURAL GAS/ LP GAS OR PROP/ GAZ NATUREL / GAZ DE PETROLE LIQUEFIE OU PROP. IN. W.C.(kPa)/ IN. W.C.(kPa)/ PO. C.E. (kPa) PO. C.E. (kPa)
MAXIMUM PERMISSIBLE GAS SUPPLY PRESSURE TO FURNACE PRESSION MAXIMUM D'ALIMENTATION EN GAZ A CHAUDIERE MINIMUM GAS SUPPLY PRESSURE FOR PURPOSES OF INPUT ADJUSTMENT PRESSION MINIMUM D'ALIMENTATION EN GAZ POUR LE REGLAGE DE PUISSANCE D'ENTREE MANIFOLD PRESSURE /PRESSION A LA TUBULURE AIR TEMPERATURE RISE/ AUGMENTATIONDE LA TEMPERATUREDE L'AIR 40°(22°) - 70°(39°)°F (°C)		5.0 (1.24) 11.0 (2.73) 5.0 (1.24) 11.0 (2.73) 3.5 (0.87) 10.0 (2.49)
MAXIMUM EXTERNAL STATIC PRESSURE PRESSION STATIQUE EXTERIEURE MAXIMAL INCHES W.C. (kPa)-PO. C.E. (kPa) 1.00 (038) 1.00 (249)		91-22176-11
ASSEMBLED IN MEXICO		ST-A1194-99-00

# ELECTRICAL WIRING

## ELECTRICAL WIRING

### **⚠ WARNING**

TURN OFF ELECTRIC POWER AT FUSE BOX OR SERVICE PANEL BEFORE MAKING ANY ELECTRICAL CONNECTIONS. FAILURE TO DO SO CAN CAUSE ELECTRICAL SHOCK RESULTING IN PERSONAL INJURY OR DEATH.

### **⚠ WARNING**

THE CABINET MUST HAVE AN UNINTERRUPTED GROUND ACCORDING TO THE LATEST EDITION OF THE NATIONAL ELECTRICAL CODE, ANSI/NFPA70- OR IN CANADA, THE CANADIAN ELECTRICAL CODE, CSA-C221 OR LOCAL CODES THAT APPLY. DO NOT USE GAS PIPING AS AN ELECTRICAL GROUND. A GROUND SCREW IS PROVIDED IN THE JUNCTION BOX. FAILURE TO DO SO CAN CAUSE ELECTRICAL SHOCK RESULTING IN PERSONAL INJURY OR DEATH.

### **⚠ WARNING**

THIS FURNACE IS EQUIPPED WITH A BLOWER DOOR SAFETY SWITCH. DO NOT DISABLE THIS SWITCH. FAILURE TO FOLLOW THIS WARNING CAN RESULT IN ELECTRICAL SHOCK, PERSONAL INJURY OR DEATH.

**IMPORTANT:** The furnace must be installed so that the electrical components are protected from water (condensate).

Before proceeding with the electrical connections, be certain that the voltage, frequency and phase corresponds to that specified on the furnace rating plate. For single furnace application, see rating plate for maximum over-current protection.

Use a separate fused branch electrical circuit containing a properly sized fuse or circuit breaker. Run this circuit directly from the main switch box to an electrical disconnect that is readily accessible and located near the furnace (as required by code). Connect from the electrical disconnect to the junction box on the left side of the furnace, inside the blower compartment. For the proper connection, refer to the appropriate wiring diagram located on the inside cover of the furnace control box and in these instructions.

ANSI/NFPA70 or, in Canada, The Canadian Electrical Code and local codes having jurisdiction.

These may be obtained from:

National Fire Protection Association, Inc.  
Batterymarch Park  
Quincy, MA 02269

CSA - International  
5060 Spectrum Way  
Mississauga, Ontario  
Canada L4W 5N6  
online: www.csa.ca

**FIGURE 44**  
DOOR SWITCH REMOVAL INSTRUCTIONS

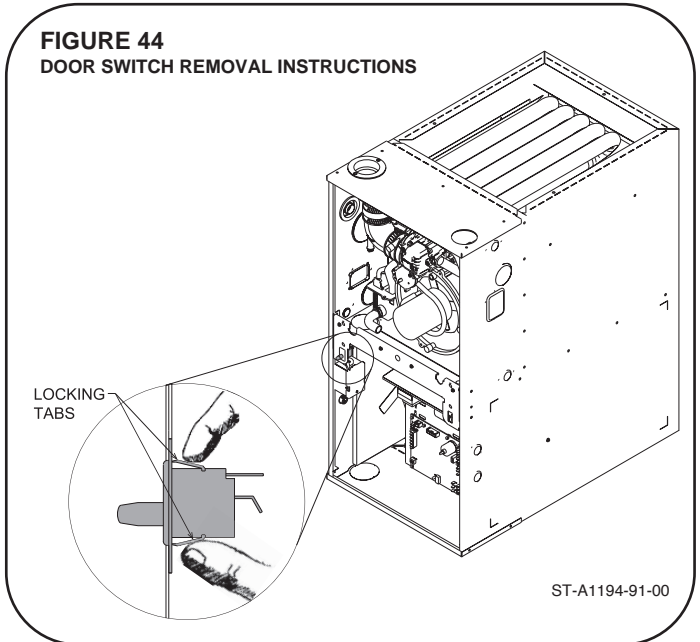

## REVERSING THE ELECTRICAL CONNECTION (JUNCTION BOX)

**NOTE:** The electrical junction box may be moved to the right side if necessary. A knockout is provided. Seal the opposite hole with plug provided.

**NOTE:** L1 (hot) and L2 (neutral) polarity must be observed when making field connections to the furnace. The ignition control may not sense flame if L1 and L2 are reversed. Make all electrical connections in accordance with the latest edition of the National Electrical Codes.

If the line voltage electrical needs to be moved to the opposite side of the furnace, the following steps should be taken:

1. The furnace must NOT be electrically connected to line voltage prior to reversing the electrical connection.
2. Disconnect the wires from the door switch. When un-mating wire terminal from 1/4" spade terminal, grasp the terminal from the housing with fingers and pull straight against 1/4" spade terminal without prying. See Figure 44. Take caution not to disconnect the terminal by pulling on the wire itself to prevent contact deformation or damage. Deformation of contact may cause defective contact.

# ELECTRICAL WIRING

## REVERSING ELECTRICAL CONNECTION & THERMOSTAT

3. Remove the junction box from the furnace cabinet wall by removing the two screws that hold it to the cabinet. Leave the wires connected to the junction box.
4. Remove 7/8" plug from hole opposite j-box location. Drill 2 @ 3/16" Ø holes in the jacket. **NOTE:** Dimples/marks are provided in the sheet metal for correct drilling location.
5. Move the junction box to the opposite side of the cabinet. Install using the two screws removed in step 3 above. Note that all screws penetrating the junction box must be blunt – no sharp tipped screws can be used.
6. Replace the plug from the opposite of the furnace (the new j-box location) to the old j-box location and install qty=2 1/4" plugs from parts bag in empty screw holes in old location of j-box into the mounting screw holes in the old junction box location.
7. Using the thumb and forefinger, squeeze the retaining arms on the door switch and gently rock the retaining arms until one comes loose. The second retaining arm can then be removed easily from the opening. See Figure 44.
8. Install the door switch in the same opening on the opposite of the furnace and reconnect the electrical connectors (removed in Step 2) to the door switch. To mate wire terminal to 1/4" spade terminal, grasp the terminal from the housing with fingers and push straight against 1/4" spade terminal. This low insertion force flag terminal will deliver an audible click when engaged. Failure to engage will cause defective contact.

**NOTE:** Do not use 24 volt control wiring smaller than No. 18 AWG.

Install the room thermostat in accordance with the instruction sheet packed in the box with the thermostat. Run the thermostat lead wires inside the blower compartment and connect to low voltage terminals as shown on the wiring diagram. Never install the thermostat on an outside wall or where it will be influenced by drafts, concealed hot or cold water pipes or ducts, lighting fixtures, radiation from fireplace, sun rays, lamps, televisions, radios or air streams from registers.

**FIGURE 45**  
ISOLATION RELAY

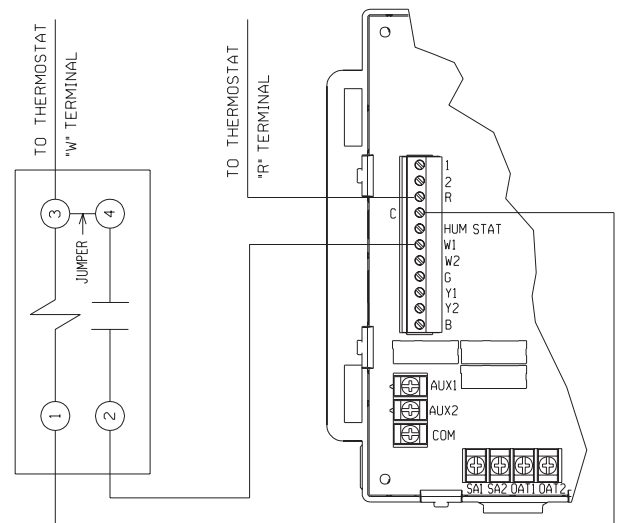

ST-A1194-75-00

## THERMOSTAT

The room thermostat must be compatible with the furnace. See manufacturer's thermostat spec sheet for compatibility concerns. Generally, all thermostats that are not of the "current robbing" ("current robbing" thermostats require the addition of an isolation relay. See Figure 45) types are compatible with the integrated furnace control. The low voltage wiring should be sized as shown.

# ACCESSORIES

## FIELD INSTALLED OPTION ACCESSORIES

### ELECTRONIC AIR CLEANER

Line voltage power can be supplied from the terminal labeled “EAC” and a line voltage neutral terminal on the control board. This will power the electronic air cleaner whenever the circulating air blower is in operation.

**NOTE:** The electronic air cleaner output will not be energized when the ECM blower motor target CFM is below the following thresholds:

- 60k = 500 CFM
- 70k = 500 CFM
- 85k = 600 CFM
- 100k = 600 CFM
- 115k = 600 CFM

Under some circumstances, such as low-speed continuous fan, the target blower CFM may be below the above threshold. In these cases the electronic air cleaner output will NOT be energized.

**NOTE:** Maximum current is 1.0 amps for the electronic air cleaner output.

### HUMIDIFIER

Humidifier output is a set of dry contacts. The logic controlling these contacts and the necessary wire diagrams for installing a humidifier are detailed in the section of this manual titled *Humidification/Dehumidification*.

### FILTERS (See Figure 46)

Keep filters clean at all times. **A filter is not provided with the furnace, but one must be field-supplied and installed.**

It is recommended to replace the furnace filter periodically to maintain optimum furnace performance.

### TWINNING

Twinning of these furnaces is NOT permitted!

### AIR TEMPERATURE SENSORS

Outdoor Air Temperature Kit RXGJ-J02

Supply Air Temperature Sensor 47-24225-01

Refer to supply/outdoor air temperature section of integrated furnace control for more detailed information.

## FIELD INSTALLED OPTION ACCESSORIES (cont.)

**FIGURE 46**  
FILTER LOCATIONS

### UPFLOW/HORIZONTAL

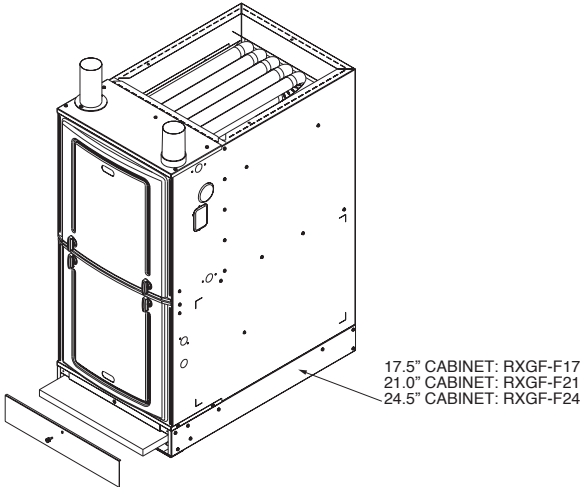

ST-A1194-10

### SIDE RETURN

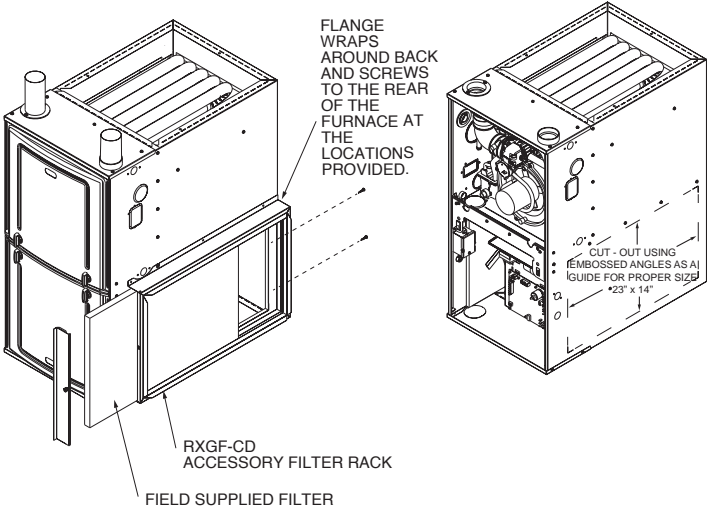

ST-A1194-11

# CALIBRATION SEQUENCE OF OPERATIONS

## WARNING

SHOULD OVERHEATING OCCUR OR THE GAS SUPPLY FAIL TO SHUT OFF, CLOSE THE MANUAL GAS VALVE FOR THE APPLIANCE BEFORE SHUTTING OFF THE ELECTRICAL SUPPLY. FAILURE TO DO SO CAN CAUSE AN EXPLOSION OR FIRE RESULTING IN PROPERTY DAMAGE, PERSONAL INJURY OR DEATH.

## WHAT'S UNIQUE ABOUT MPL MODEL 9375 PRESSURE SWITCHES

MPL Model 9375 pressure switches have calibrated Make points (contacts close) versus calibrated Break points (contacts open) experienced with most pressure switches used in a Rheem furnace. The 98% modulating furnace will calibrate inducer RPM's based on the Make point of the low, mid and high fire pressure switches.

## CALIBRATION SEQUENCE OF OPERATION

### HONEYWELL CONTROLS Integrated Controls with Direct Spark Ignition

A typical calibration sequence is performed prior to the pre-purge under the following conditions:

1. The first gas heat call after cycling of main power (line voltage).
2. Once every 1000 heat calls.

#### Notes:

1. During calibration, the IFC (Integrated Furnace Control) determines the minimum inducer RPM necessary to keep respective pressure switches closed. The feature enhances the high energy efficiency experienced with this model.
2. Burner compartment door must be ON furnace before calibration sequence begins.
3. The IFC will finish the cold and warm calibration even if gas heat call is removed during the calibration process.
4. During the initial or start-up call for heat, if the condensate trap has not been primed, a **water sensed** fault (59) may occur during warm calibration. The gas valve circuit will be de-energized and the calibration sequence will begin anew.

#### Calibration Cycle

The seven-segment display "CL" (for Calibration) at the start of the cold calibration and through the warm calibration sequence. Normal calibration sequence will take approximately 9.5 minutes to complete.

#### Cold Calibration- Low Pressure Switch

The IFC will energize the inducer at a low starting RPM and increase the inducer speed until the low pressure switch closes. At this point, the IFC notes the inducer RPM when the low pressure switch closes and adds this value to a predetermined value and saves the result in memory.

#### Cold Calibration- Mid-Pressure Switch

The furnace IFC will continue increasing the inducer RPM until the mid. pressure switch closes. At this point, the IFC notes the inducer RPM when the mid. pressure switch closes and adds this value to a predetermined value and saves the result in memory.

#### Cold Calibration- High Pressure Switch

The furnace IFC will continue increasing the inducer RPM until the high pressure switch closes. At this point, the IFC notes the inducer RPM when the high pressure switch closes and adds this value to a predetermined value and saves the result in memory.

Immediately following cold calibration the furnace IFC begins a 30 second pre-purge period and up to a 7 second Trial for Ignition (spark ignitor is energized). Following burner ignition the furnace will begin a 2 minute warm-up period. Following the warm-up period, the IFC will determine the necessary inducer RPM corresponding to the open and closed points of the high, mid and low fire pressure switches.

#### Warm Calibration- High Fire Pressure Switch

Inducer RPM will decrease steadily until the high fire pressure switch opens. The inducer RPM is then increased steadily until the high fire pressure switch closes. At this point the IFC notes the inducer RPM when the high fire pressure switch closes and adds this value to a predetermined value and saves the result in memory. This value is used as the target RPM for 70% to 100% firing rates.

#### Warm Calibration- Mid-fire Pressure Switch

Gas valve output is reduced to 65%. The inducer RPM is decreased steadily until the mid-fire pressure switch opens. The inducer RPM is then increased steadily until the mid-fire pressure switch closes. At this point the IFC notes the inducer RPM when the mid-fire pressure switch closes and adds this value to a predetermined value and saves the result in memory. This value is used as the target RPM for 50% to 65% firing rates.

#### Warm Calibration- Low Fire Pressure Switch

Gas valve output is reduced to 40%. The inducer RPM is decreased steadily until the low fire pressure switch opens. The inducer RPM is then increased steadily until the low fire pressure switch closes. At this point the IFC notes the inducer RPM when the low fire pressure switch closes and adds this value to a predetermined value and saves the result in memory. This value is used as the target RPM for 40% firing rates.

Calibration complete. Furnace will respond to thermostat demand.

# START-UP AND SEQUENCE OF OPERATIONS

**Note:** If the calibration attempt fails or fault codes are present, see **Table 18, 98% modulating furnace Fault Codes with Description and Solutions.**

## **Burner Ignition**

Upon proving flame from successful ignition, the IFC continues in the following way:

1. If calibration cycle is active:  
The IFC proceeds to the Warm Calibration following the 2 minute warm-up period.
2. If Calibration Cycle is not active:  
Warm-up period will be active for 2 minutes.

The firing rate should be set to 100 % for the first 22 seconds of the Warm-up period and then the IFC will accept the thermostat demand.

## **Blower On Delay**

The IFC waits 22 seconds after the start of the ignition trial to energize the main blower during heat mode (call for heat).

During the 2 minute warm-up period, the furnace control uses the inducer RPM's determined during the cold calibration sequence for the low, mid and high pressure switches. When the Warm-up period ends, the furnace control will use the inducer RPM's determined during the warm calibration sequence and the IFC proceeds to the Steady State Heating mode.

## **Steady State Heat**

Heating blower CFM values will be a function of the current firing rate and the selection of comfort or efficiency heating modes (dipswitch SW-18 or, for communicating systems, selected in the Econet Control Center) and the arrangement of the low and high heating airflow adjustments using dipswitches SW13, SW14, SW15 and SW16 (for communicating systems, the adjustment is made at the Econet control center).

## **Inducer Post-Purge**

Inducer will continue to run for 28 seconds at mid-fire RPM after the gas valve is de-energized.

## **Blower Off Delay**

The blower off delay is to always begin after the gas valve is de-energized or when detected error conditions that have been cleared require blower to be energized and then de-energized. It is user-selectable per dipswitch SW17 or, for communicating systems, the value selected at the Econet control center. The blower off delay will take place at the same CFM demand that the blower was at the time of the gas valve de-energizing or at CFM matching 100% firing rate if the blower was off.

If a compressor call becomes present during the heat blower "off" delay, the IFC will immediately switch the blower output to the greater of the cool call and heat call CFM until the end of the blower "off" delay. At the end of the blower off delay, the blower CFM shall be set to the cool or HP CFM.

## **Blower Off Delay**

The blower off delay is to always begin after the gas valve is de-energized or when detected error conditions that have been cleared require blower to be energized and then de-energized. It is user-selectable per dipswitch SW17 or, for communicating systems, the value selected at the Econet control center. The blower off delay will take place at the same CFM demand that the blower was at the time of the gas valve de-energizing or at CFM matching 100% firing rate if the blower was off.

If a compressor call becomes present during the heat blower "off" delay, the IFC will immediately switch the blower output to the greater of the cool call and heat call CFM until the end of the blower "off" delay. At the end of the blower off delay, the blower CFM shall be set to the cool or HP CFM.

1. **P1 (8-Pin), P2 (6-Pin) and P7 (5-Pin)**

**Low-Voltage Internal Wiring Connections** – Connect main twist-lockwire harness to these connections. Pre-wired from the factory.

2. **RJ-14 CONNECTOR (J1)**

This connector is used to program the furnace control at the factory. It may also be connected in the field to certain Econet devices. It should never be connected to a telephone line or a telephone. Doing so could damage the furnace control or the telephone (or telephone lines) or both.

## **WARNING**

**DO NOT CONNECT A TELEPHONE OR PHONE LINE TO THE CONNECTOR (JACK) AT POSITION J-1. DOING SO COULD CAUSE IRREPARABLE DAMAGE TO EITHER THE FURNACE CONTROL (I.F.C.) OR THE TELEPHONE (OR TELEPHONE LINE) OR BOTH.**

3. **SPARK IGNITION TRANSFORMER (T1)**

The spark ignition transformer resides on the furnace control. The transformer provides spark energy at approximately 60 hz frequency and a minimum of 12KV.

4. **BIAS / TERMINATION (S4)**

**For current installations, all three of the dip-switches in bank SW4 must be in the "OFF" position. If not, the system may not be able to communicate.**

5. **COMMUNICATIONS LED'S (CR36 & CR38)**

Two LED's are provided to indicate the status of communications. A red LED (labeled TX) is provided for transmit and a green LED (labeled RX) is provided for receive. These LED's will be lit in an undefined pattern when other communicating components are attached and communicating with the furnace control.

# INTEGRATED FURNACE CONTROL

**FIGURE 47**  
FURNACE CONTROL BOARD OR IFC (INTEGRATED FURNACE CONTROL)

**Integrated Furnace Control**

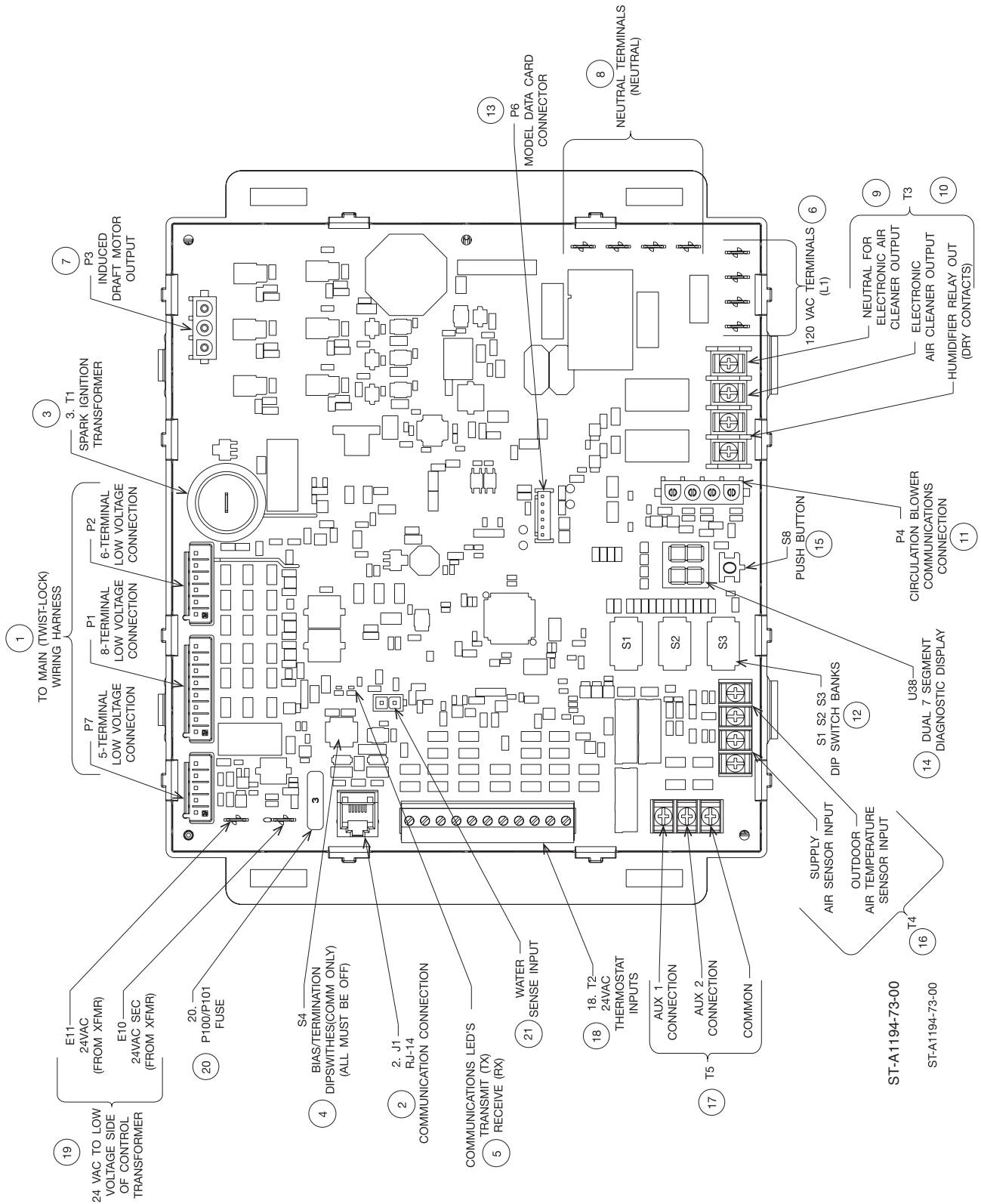



# START-UP AND SEQUENCE OF OPERATIONS

## 6. LINE VOLTAGE CONNECTIONS (120VAC, L1)

Four ¼" spade terminals are provided for internal connections and accessories.

## 7. INDUCED DRAFT MOTOR (INDUCER) OUTPUT(P3)

This three-pin Mate-n-Lok style connector provides power to the inducer.

## 8. NEUTRAL TERMINALS (NEUTRAL)

Four ¼" spade terminals are provided for internal connections and accessories.

## 9. ELECTRONIC AIR CLEANER (EAC.) OUTPUT (T3)

This output is used to energize an electronic air cleaner. The output will provide up to 1.0 amp at 115 VAC. This output is energized any time the blower motor is above the airflow CFM values specified below. Airflow below these values is not considered to be enough for a typical electronic air cleaner to perform properly.

For ½ HP motors - Electronic air cleaner is energized any time the blower is above 500 CFM

For ¾ HP motors - Electronic air cleaner is energized any time the blower is above 600 CFM

Some lower fan speeds may not deliver enough airflow to operate an electronic air cleaner. The IFC determines the minimum airflow necessary to operate an electronic air cleaner and will not turn on the electronic air cleaner unless the airflow is high enough for the EAC.

## 10. HUMIDIFICATION (T3) AND DEHUMIDIFICATION

**HUMIDIFIER** – The humidifier contacts (labeled "HUM" (2)) are "dry" contacts on the I.F.C. This means that the terminals are connected directly to the contacts of a board-mounted relay. The coil of the relay is controlled by the microprocessor of the IFC. The coil is engaged any time the heat speed blower is engaged and (1) 24VAC is present on the thermostat terminal of the IFC labeled "HUM STAT" or (2) a communicating thermostat with humidification and dehumidification capability is installed with call for humidification present. (See Figure 47 for location of humidification/dehumidification inputs on furnace control.)

An optional 24VAC humidistat can be installed as shown in Figures 49 thru 52. With the optional humidistat, two separate conditions must be met before humidification can begin.

**FIGURE 48**  
ELECTRONIC AIR CLEANER AND HUMIDIFIER TERMINALS

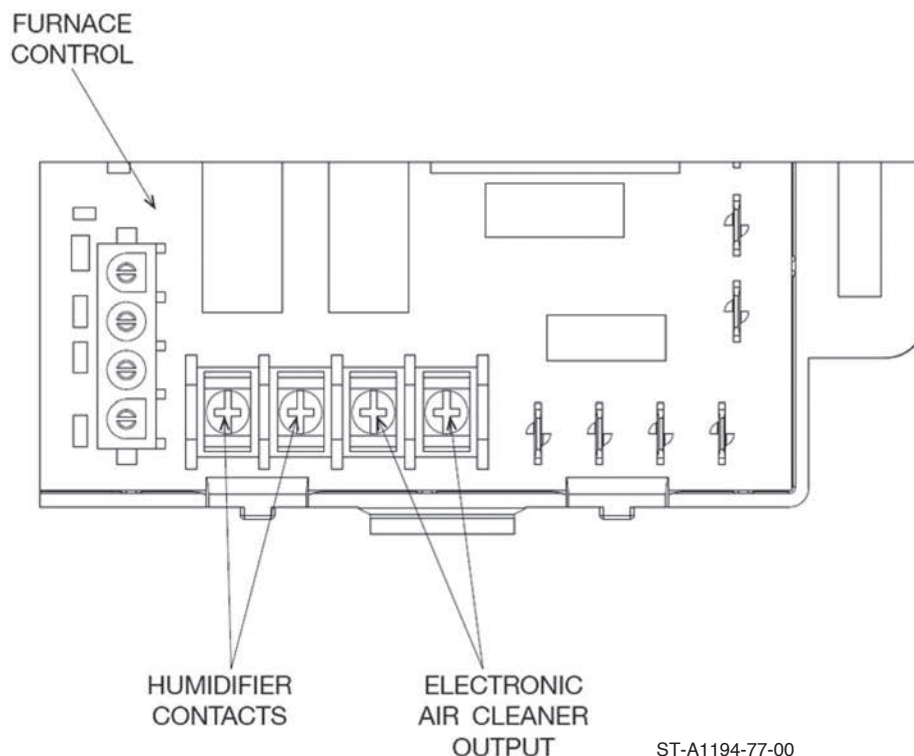

ST-A1194-77-00

# START-UP AND SEQUENCE OF OPERATIONS

- 1.) There must be a call for heat and the blower must be engaged and
- 2.) The humidistat must determine that there is a need for humidification.

Note: Dipswitch S2-8 (labeled “ODD”) enables (“ON”) or disables (“OFF”) de-humidification operation.

However, it has no effect on humidification operation. If this switch is set to the “ON” position and no humidistat is installed, the cooling airflow will be reduced by approximately 15% giving less than optimal performance and possibly causing problems. It is not recommended to leave this switch in the “ON” position without a humidistat installed. Control of dehumidification in cooling and/or humidification in heating can be done with a variety of methods depending on whether there is a communicating thermostat or a humidistat available and depending on the type of operation desired.

With systems configured with communicating thermostats and condensers, dehumidification is controlled by the thermostat and is not affected by the position of dipswitch SW2-1 or the voltage at the thermostat input T2 labeled “HUM STAT” on the furnace. To determine which wiring

diagram and method to use, select from the following configurations:

## A. HUMIDIFICATION CONTROL ONLY WITH NO DEHUMIDIFICATION (REQUIRES OPTIONAL HUMIDIFIER).

### A1. WITH COMMUNICATING THERMOSTAT

Humidifier control is included with EcoNet control center. To wire the furnace for humidification control using an EcoNet communicating thermostat, refer to the wiring diagram in Figure 49 Option A. Be sure not to install the jumper between “R” and “HUMSTAT” on the furnace control. Installing this jumper will operate the humidifier any time there is a heat call or a call for constant fan. Without the jumper, the humidification call from the thermostat must be active and a heat call must be present with the blower running.

### A2. WITH NON-COMMUNICATING THERMOSTAT

#### A2-1 CONTINUOUS HUMIDIFIER OPERATION DURING HEATING.

For continuous humidifier operation during heating, refer to Figure 49 Option B and make sure to install the jumper between the thermostat terminals labeled “R” and “HUM

**FIGURE 49**  
**WIRING FOR OPTIONAL HUMIDIFICATION (AND DE-HUMIDIFICATION WITH COMMUNICATING THERMOSTAT) WITH OPTIONAL HUMIDIFIER AND NO HUMIDISTAT (HUMIDIFICATION ACTIVE DURING ANY HEAT CALL)**  
**(FOR USE WITH COMMUNICATING OR NON-COMMUNICATING THERMOSTATS)**

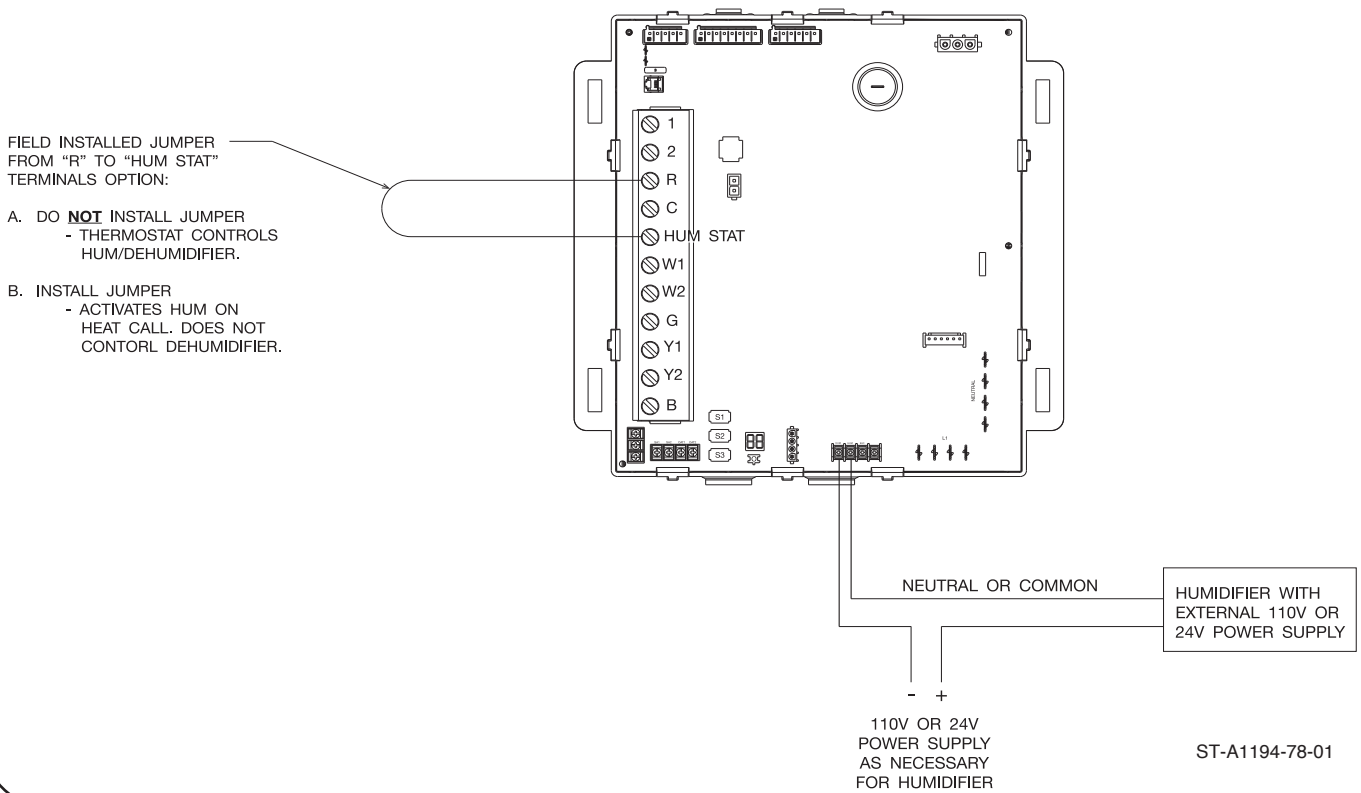

# START-UP AND SEQUENCE OF OPERATIONS

## HUMIDIFICATION/DEHUMIDIFICATION

STAT". A separate humidistat is not required for this configuration and the humidifier will turn on whenever there is a call for heat and the blower is running.

### A2-2 CONTROLLED HUMIDIFIER OPERATION USING A HUMIDISTAT (REQUIRES OPTIONAL HUMIDISTAT).

Controlled humidification can be accomplished using a humidistat as shown in Figures 49 or 50. These figures show installation of a humidifier with external and internal power supplies respectively. Dehumidification operation will be disabled if the dipswitch S2-8 is in the "OFF" position. If this switch is in the "ON" position, dehumidification control will be active.

### B. DEHUMIDIFICATION CONTROL WITH NO HUMIDIFICATION

#### B1. WITH COMMUNICATING THERMOSTAT

For communicating thermostats listed with this furnace, dehumidification is controlled automatically when selected at the thermostat and additional wiring is not necessary. The actual airflow demand (reduced for dehumidification) is requested of the furnace by the thermostat.

#### B2. WITH NON-COMMUNICATING THERMOSTAT (REQUIRES OPTIONAL HUMIDISTAT)

Control of dehumidification only (no humidification) can be accomplished by installing an optional humidistat as shown in Figure 50. The dipswitch S2-8 must be set to the "ON" position. If this switch is not turned "ON", dehumidification operation will not take place. Further, if this switch is "ON" and no humidistat is installed, airflow in cooling will be permanently reduced by approximately 15%.

### C. HUMIDIFICATION AND DE-HUMIDIFICATION CONTROL (REQUIRES OPTIONAL HUMIDIFIER).

#### C1. WITH COMMUNICATING THERMOSTAT

Humidifier control is included with EcoNet communicating thermostats. To wire the furnace for humidification and dehumidification control using an EcoNet communicating thermostat, refer to the wiring diagram in Figure 49 Option A. Be sure not to install the jumper between "R" and "HUM STAT" on the furnace control for thermostat controlled option. Without the jumper, a humidification call from the thermostat must be active and a heat call must be present with the blower running for the "HUM" relay contacts to close.

**FIGURE 50**  
WIRING FOR OPTIONAL DE-HUMIDIFICATION AND HUMIDIFICATION (WITH OPTIONAL HUMIDISTAT AND HUMIDIFIER).  
NOTE: CAN BE USED WITH COMMUNICATING OR NON-COMMUNICATING SYSTEMS.

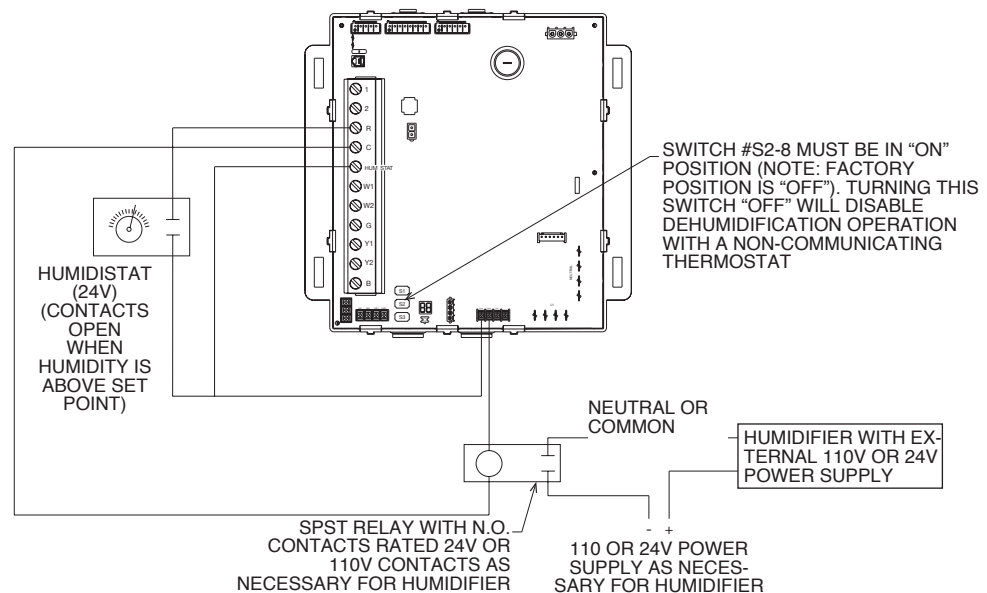

ST-A1194-79-00

# INTEGRATED FURNACE CONTROL

## HUMIDIFICATION/DEHUMIDIFICATION

**FIGURE 51**  
WIRING FOR OPTIONAL DE-HUMIDIFICATION AND HUMIDIFICATION (WITH OPTIONAL HUMIDIFIER) (HUMIDIFIER WITH INTERNAL POWER SUPPLY. NOTE: FOR USE WITH NON-COMMUNICATING SYSTEMS.

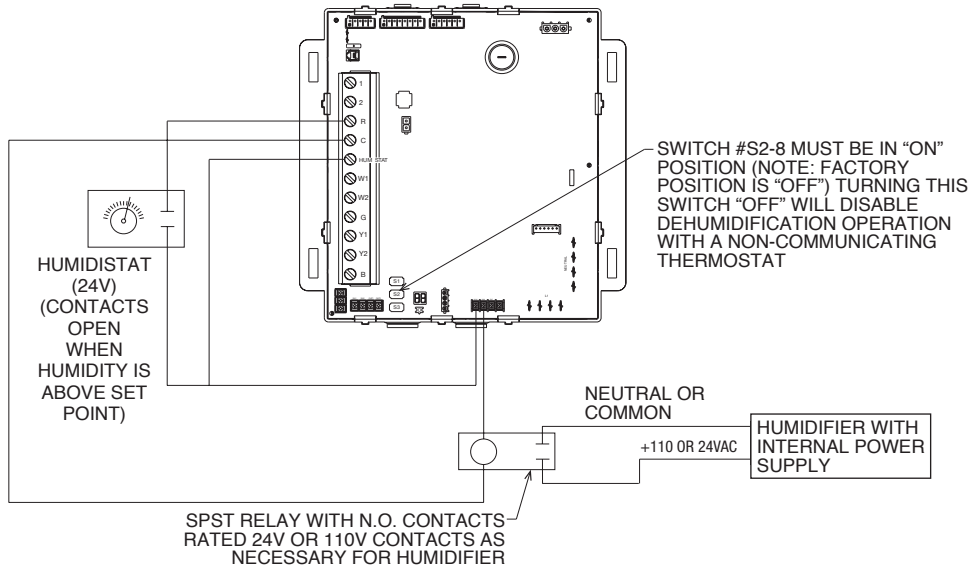

ST-A1194-80-00

Integrated Furnace Control

Installing this jumper between "R" and "HUMSTAT" as shown in Figure 49 Option B will operate the humidifier any time there is a heating call. Dehumidification will never take place when in cooling. This option can be used for communicating and noncommunicating thermostats.

### C2. WITH NON-COMMUNICATING THERMOSTAT (REQUIRES OPTIONAL HUMIDISTAT)

For non-communicating thermostats, an optional humidistat must be installed. Controlled humidification and dehumidification can be accomplished using a humidistat as shown in Figures 51 or 52. These figures show installation of a humidifier with external and internal power supplies respectively. Dehumidification operation will be disabled if the dipswitch S2-8 is in the "OFF" position. If this switch is in the "ON" position, dehumidification control will be active.

### 11. COMMUNICATING ECM MOTOR COMMUNICATIONS (CONTROL) CONNECTION (P4)

This connector sends and receives messages to and from the blower motor through a single peer-to-peer network. The blower motor does not communicate on the same communications buss as the furnace, condenser (or heat-pump) and thermostat. Further, a different communications protocol is used.

### 12. DIPSWITCHES

#### Seven-Segment Display Orientation; SW1

As the control will be applied in a multi-position furnace, a means of changing the orientation of the seven-segment

display is required. This dipswitch is to be labeled SW1. Factory setting of the SW1 dipswitch is OFF. The factory setting display orientation is with the control placed with the low voltage terminal block T2 is on the left side.

#### Cool Blower-Off Delay; SW2 & SW3

A means of selecting the cooling speed blower "off" delay time is provided. In legacy mode, dipswitches are required to select the delay time. These dipswitches are labeled SW2 and SW3. The following table defines the settings:

Selection	SW2	SW3	Selection
A*	OFF	OFF	30 seconds
B	ON	OFF	45 seconds
C	OFF	ON	60 seconds
D	ON	ON	0 seconds

Note: Factory setting = 30 seconds

#### Cooling Airflow Selection; SW4 & SW5

SW4 and SW5 are used to select cooling airflow in legacy mode. The value used for each selection is specified below.

#### HIGH COOL SELECTIONS:

SW4	SW5	1/2 HP Blower (56 & 70 KBTU)	3/4 HP Blower (84, 98 & 112 KBTU)
OFF*	OFF	1050 CFM	1750 CFM
ON	OFF	875 CFM	1400 CFM
OFF	ON	700 CFM	1225 CFM
ON	ON	525 CFM	1050 CFM

# INTEGRATED FURNACE CONTROL

## HUMIDIFICATION/DEHUMIDIFICATION

**FIGURE 52**  
**HUMIDISTAT USED TO CONTROL DEHUMIDIFICATION IN COOLING ONLY (NO HUMIDIFIER)**  
**NOTE: FOR USE WITH NON-COMMUNICATING THERMOSTATS.**

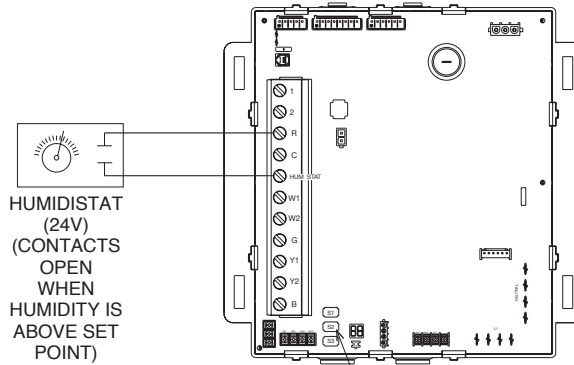

ST-A1194-81-00

SWITCH #S2-8 MUST BE IN "ON" POSITION (NOTE: FACTORY POSITION IS "OFF"). TURNING THIS SWITCH "OFF" WILL DISABLE DEHUMIDIFICATION OPERATION WITH A NON-COMMUNICATING THERMOSTAT

### LOW COOL SELECTIONS:

The following CFM's will be used for low-stage legacy cooling unless dipswitch SW9 is in the ON position - in which case the low cooling airflow becomes 50% of the high cooling airflow.

SW4	SW5	1/2 HP Blower (56 & 70 KBTU)	3/4 HP Blower (84, 98 & 112 KBTU)
OFF*	OFF	788 CFM	1313 CFM
ON	OFF	656 CFM	1050 CFM
OFF	ON	525 CFM	919 CFM
ON	ON	394 CFM	788 CFM

\*Factory Setting

Airflow dipswitches are to be used to determine airflow when a legacy (24 VAC) call is placed on the thermostat inputs of the control. Communicated calls will have CFM requirements as part of the call (when a legacy condenser is attached to a communicating furnace the airflow demand will be transmitted from the communicating thermostat as the installer will configure the cooling airflow requirements for the non-communicating condenser at the thermostat and the airflow requirements for the condenser will be stored, at and transmitted from, the thermostat).

### Cooling/Heat Pump Airflow Trim; SW6 & SW7

Two dipswitches (SW6, SW7) are provided for legacy cool airflow trim. The value used for each selection is specified below.

Selections are as follows:

Selection	SW6	SW7	Description
A	OFF	OFF	No Cooling Adjust.*
B	ON	OFF	+10%
C	OFF	ON	-10%
D	ON	ON	No Cooling Adjust.

\*Factory Setting

### ODD (On Demand Dehumidification); SW8

One dipswitch (SW8) is provided to enable the dehumidification feature in legacy mode. Selections are as follows:

SW8=OFF	ODD not enabled. (Factory Setting)
SW8=ON	ODD enabled. 0VAC on "HUM STAT" will decrease airflow in cooling.

### Tandem Airflow Select; SW9

One dipswitch (SW9) is provided to select the percentage of airflow for the base first stage cooling airflow in legacy mode. Note that further adjustments may also be applied (e.g. for active dehumidification or cooling airflow trim).

SW9	% of 2 <sup>nd</sup> stage cooling airflow
SW9=ON	50%
SW9=OFF*	Value from dipswitches SW4 & SW5 (see above).

\*Factory Setting

### Auto Stage; SW10 & SW11

Two dipswitches are provided to either run the furnace in the single rate mode or to select between modulating, timed staging or strictly two-stage operation. Refer to the chart below for an overview of operation based on the different combinations of these two dipswitches.

# INTEGRATED FURNACE CONTROL

## DIPSWITCHES

FIGURE 53  
DIPSWITCH MAP

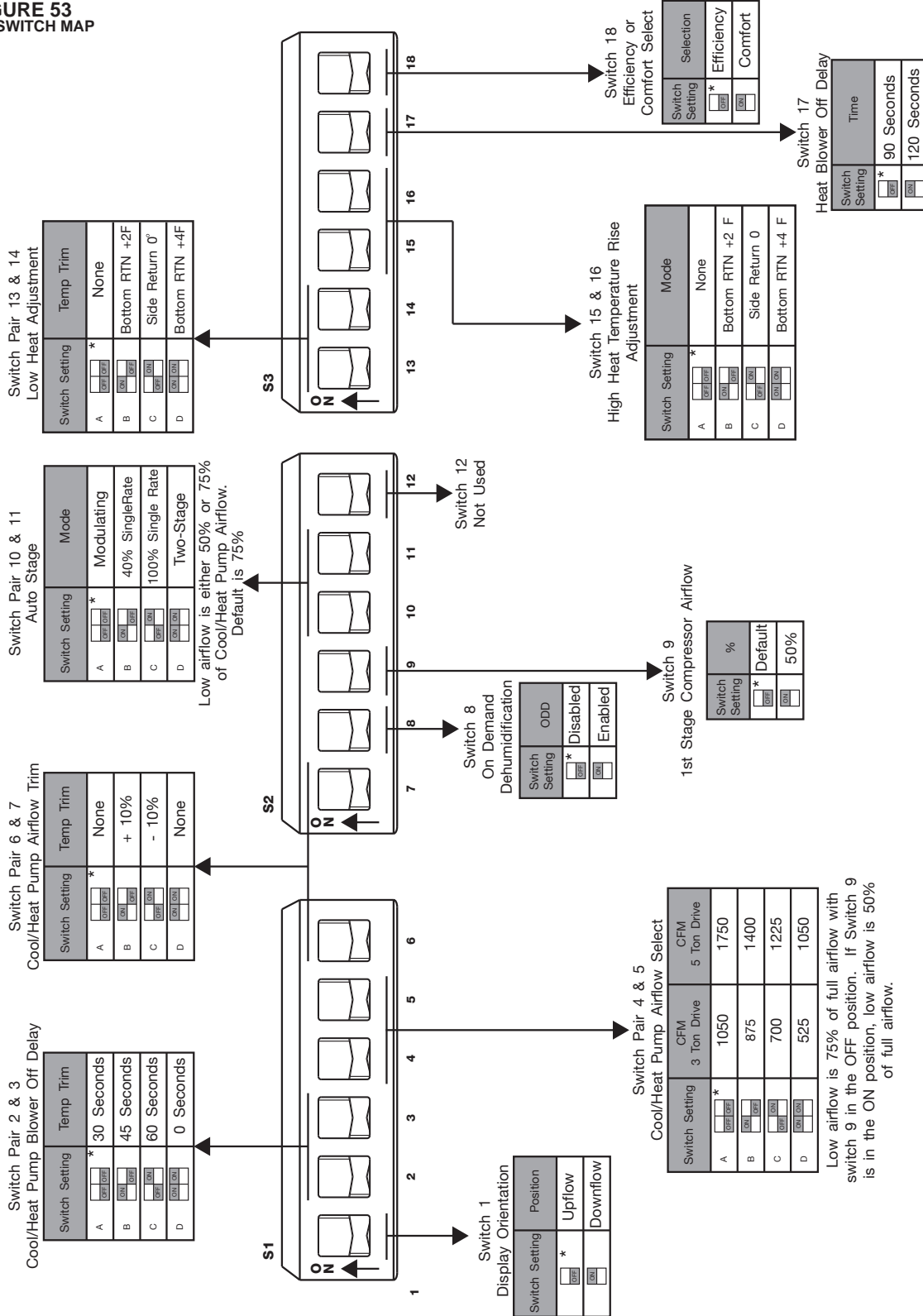

ST-A1194-83-01

\*Factory Setting (Note: Drawing shows DIP switches in their factory default position.)

**NOTE:** The ECM motor used in a modulating furnace is designed to deliver constant CFM regardless of system static pressure. Design system static pressure should never exceed 1.0 inches w.c.

# INTEGRATED FURNACE CONTROL

## DIPSWITCHES

### OFF/OFF- NORMAL OPERATION – MODULATING OR TIMED STAGING HEAT

When both Mode dipswitches are set to the “OFF” position, the furnace operates as normal to a legacy modulating heat call (“W1” with PWM signal on “V/W2”) with the firing rate adjusted by the PWM signal. The furnace operates in timed staging mode when responding to a low heat call (24 VAC present on “W1” and no signal present on “V/W2”). A call for low heat alone will start the heating sequence as normal and output the low heat rate (40% heat) for a period of ten minutes followed by a transition to a 65% heating rate. The 65% heating rate will remain active for the next ten minutes and will be followed by maximum heat (100% heat) for the remainder of the heating call. Once the control has switched to high stage heat through the staging method, the remainder of the heat call will take place at 100% heat even if a signal somehow becomes present on “V/W2”. The switch to 65% fire after ten minutes and high fire (100% heat) after a total of twenty minutes into the heat call will occur as long as there is no 24 VAC signal present at “V/W2”.

If 24VAC is sensed on “V/W2”, 100% heating operation will take place at the 100% heat rate until the end of current heat call as it is assumed that the customer wants to operate the furnace as a two-stage furnace with no timed staging. When the “V/W2” terminal becomes inactive while the “W1” request remains active, the IFC will switch to the low heat rate (40%). If the unit is already operating at 100% heat rate due to the timed staging algorithm then the IFC will continue to run at 100% heat rate for the rest of the heat cycle regardless of whether 24VAC is applied to or removed from “V/W2”.

If a PWM signal is sensed at terminal “V/W2”, the timed staging feature will be cancelled until the end of current heat call and normal modulating heat will take place as according to Section, item #3. If the unit is already operating at 100% heat rate due to the timed staging algorithm, then the IFC will continue to run at 100% heat rate for the rest of the heat cycle regardless of the PWM signal applied to the “V/W2” terminal.

MODE	SW10	SW11
Modulating / Timed Staging	OFF	OFF (Factory Setting)
40% single rate	ON	OFF
100% single rate	OFF	ON
Two-Stage	ON	ON

Control must be able to sense a change in PWM signal in no more than 3 seconds.

### ON/OFF- LOW HEAT SINGLE RATE MODE

For the single rate mode, when SW10 is “ON” and SW11 is “OFF”, the furnace will operate in the 40% heat mode with any legacy call for heat (first stage, second stage or modulating). A legacy heat call will cause the furnace to go through a normal heating cycle with heating fire rate fixed at 40%. The voltage at the terminal labeled “V/W2” will be ignored.

### OFF/ON- HIGH HEAT SINGLE RATE MODE

When SW10 is “OFF” and SW11 is “ON”, the furnace will operate in the 100% heat mode with any legacy call for heat (first stage, second stage or modulating). That is, a 24 VAC signal on “W1” will cause the furnace to go through a normal heating cycle with heating fire rate fixed at 100%. The voltage at the terminal labeled “V/W2” will be ignored.

### ON/ON - RESPONSE TO TWO-STAGE THERMOSTAT WITH 3 STAGES OF HEAT OPERATION

When both Mode dipswitches are set to the “ON” position, a 24VAC signal present on “W1” with no signal on “V/W2” will always operate low-fire heat (40% heat rate). With 24VAC present on both “W1” & “V/W2” the IFC will operate at 65% gas heat for ten minutes followed by 100% heat until 24 VAC is no longer present on “V/W2”. This sequence will be triggered also when 24VAC signal on “V/W2” appears during “W1” operation.

When both Mode dipswitches are set to the “ON” position, the furnace operates as normal to a modulating heat call (“W1” with PWM signal on “V/W2”) with the firing rate adjusted by the PWM signal.

### Not Used; SW12

### Gas Heat Rise Adjustment; SW13, SW14, SW15 & SW16

Four dipswitches are provided to adjust the low end and high end heating performance. The switches are labeled “LO ADJ” (SW13 & SW14) and “HI ADJ” (SW15 & SW16). These switches adjust temperature rise to accommodate user preference and installation type. Furnaces installed with a side return should set switches SW14 and SW16 to the ON position (as well as operate in Efficiency Mode):

Selection	SW13	SW14	Description
A	OFF	OFF	Nominal Value Specified on Rating Label (Factory Setting) (Approx.)
B	ON	OFF	Bottom Return +2°F
C	OFF	ON	Not Used
D	ON	ON	Bottom Return +4°F.

Selection	SW15	SW16	Description
A	OFF	OFF	Nominal Value Specified on Rating Label (Factory Setting) (Approx.)
B	ON	OFF	Bottom Return +2°F
C	OFF	ON	Not Used
D	ON	ON	Bottom Return +4°F.

# INTEGRATED FURNACE CONTROL

Additionally, the adjustment to the low-end will affect a linear adjustment to the entire range of heating airflow except at the 100% rate. The adjustment to the range will be such that the 40% heating rate will be adjusted up or down as specified by the dipswitch settings, the 100% heating rate may also be adjusted up or down and all points in between will fall on a line created by the adjusted 40% heating airflow rate and the adjusted (or unadjusted) 100% heating airflow rate.

Further, for communicating systems, the above selections (made with dipswitches SW13, SW14, SW15, and SW16 in legacy mode) can be made via the Econet control center.

## **Heat Blower Off Delay; SW17**

One dipswitch (SW17) is to be provided for heat blower off delay selection.

SW17 = Off 90 second\*

SW17 = On 120 second

## **Efficiency or Comfort Select; SW18**

SW 18 will select between comfort heat (on) and efficiency heat (off - factory setting).

SW18 = On Comfort = Target Temp rise = +4°F above mid Rise\*

SW18 = Off Efficiency = Target Temp rise = mid-rise (as specified on rating label).

\*Factory Setting

## **Bias/Termination; S4**

For current installations, all three of the dipswitches in bank S4 must be in the "OFF" position.

If not, the system may not be able to communicate.

## **13. MODEL DATA CARD CONNECTOR (P6)**

There is a factory-installed model data card which is plugged into the furnace control and wire-tied to the furnace. At no time should this card be removed from the furnace except during replacement of the card itself.

### **MODEL CARD**

A model data card is defined as an electronic card that carries a copy of the furnace model data. The furnace control receives model-specific data from the model data card. Replacement model data cards with the appropriate furnace model data for any given model can be ordered from the Replacement Parts division. In the event that the original model data card is lost, the original furnace control has been replaced and there is no furnace model data, the replacement model data card must be ordered and installed into the connector at P6 to give the furnace valid furnace model data. The furnace will not operate properly without the correct furnace model data. When no furnace model data is present either on the model data card or on the furnace microprocessor a "d1" (NO MODEL DATA) fault code will be displayed at both the thermostat active fault screen and at the furnace control (I.F.C.) seven-seg-

ment displays.

If the original model data card is lost, it should be replaced even if there is valid furnace model data on the IFC microprocessor. The valid furnace model data on the IFC microprocessor should only be considered as a backup to the model data card.

## **14. DUAL SEVEN-SEGMENT DISPLAY AND FAULT CODES (U38)**

**NOTE:** Verify display orientation is correct before interpreting fault codes. Otherwise the fault codes may be upside down.

A dual seven-segment display is provided to display status and diagnostic code information. A fault level 1 is a low-level fault. In general, a level 2 fault is a fault that is severe enough that it prevents furnace or other critical (e.g. cool-

## **▲ WARNING**

**DO NOT REPLACE THE FURNACE CONTROL OR MEMORY CARD OF THE FURNACE WITH A FURNACE CONTROL OR MEMORY CARD OF ANOTHER FURNACE OR ANOTHER COMPONENT (E.G.: A MEMORY CARD FROM A CONDENSER OR AIR HANDLER). THE WRONG FURNACE CONTROL OR MEMORY CARD MAY SPECIFY PARAMETERS WHICH WILL MAKE THE FURNACE RUN AT UNDESIRED CONDITIONS INCLUDING (BUT NOT NECESSARILY LIMITED TO) REDUCED AIRFLOW DURING HEATING CAUSING EXCESSIVE UNDESIRED OPERATION OF THE MAIN LIMIT CONTROL. FURTHER, THE MEMORY CARD IS SPECIFIC TO THE MODEL NUMBER AND BTU INPUT RATING FOR A SPECIFIC FURNACE AND THIS INFORMATION SHOULD NOT BE TRANSPORTED FROM ONE FURNACE (OR COMPONENT) TO ANOTHER.**

ing) operation. Level 1 faults generally permit operation to continue but operation may not be at optimum performance (e.g. blower operating at power maximum). Standard operating codes (e.g. C for high-stage cooling) are considered fault level "0" as they are not faults at all but only indications of current modes of operation which are considered normal (some operational codes are displayed simultaneously with low-level faults which do not interrupt operation - see paragraphs below for details).

Since usually only one fault can be displayed at the seven-segment display at any given time (see exceptions below), the fault displayed when two or more faults are present at the same time shall be resolved by the fault code list below which calls out the fault code priority. Smaller numbers are considered higher priority than larger numbers. Therefore, fault code priority 1 has the highest priority and shall be displayed when present regardless of any other fault that might also be present at the same time. This mechanism does not prevent simultaneous



# INTEGRATED FURNACE CONTROL

## DUAL SEVEN SEGMENT DISPLAY

faults from being logged into the fault code buffer.

The mode displays for heat mode (“h” “H”) shall reflect the demand from the thermostat. This includes the following:

When thermostat demand is interpreted as 40% gas heat and during the ignition period the furnace control will display the lower-case “h” and not the upper-case “H” during ignition (since the modulating furnace ignites at high stage).

Two exceptions to this rule exist as follows:

1. When autostaging has been activated and a response to “W1” heat has been increased to high heat by the furnace control after the user-specified time even though a call for high heat (“W2”) is not present. In this case a capital “H” shall be displayed and not a lower-case “h”.
2. Low pressure switch fails 5 times in one heat call. Then device is forced to the high rate to reveal possible **Water Sensed** condition. An upper-case “H” is displayed in this circumstance regardless of the thermostat demand.

When the furnace is in a heat or cool blower off delay, the display should be “0”.

A standard operating code (with fault level “0”) shall be displayed steady-on.

When displaying a fault code, it shall be flashed and not be displayed steady-on. It shall be flashed on for one second, then off for ½ second then on again. Cycle repeats until the fault is cleared. Each fault is flashed (displayed) a minimum of two times even if the fault condition has cleared before the fault can be displayed twice.

### Dual Faults Displayed

Normally only one fault or status character is displayed at the Seven-segment display at any given time. Exceptions for some dual faults are noted below.

Sequence of display:

- A. The first fault will be displayed for one second.
- B. The upper-most horizontal segment of the right seven-segment display is energized for ½ second.
- C. The second fault is displayed for one second.
- D. The upper-most horizontal segment of the right seven-segment display is energized for ½ again.

This cycle repeats until one or both faults are gone or otherwise as noted below:

1. When both high pressure switch and low pressure switch are open and both should be closed fault codes “45” and “57” will be displayed alternately as described above (A-D).
2. When a failed ignition has occurred four times in a row, the control enters one-hour lockout and fault codes “10” and “11” will be displayed alternately as described above (A-D).
3. When flame is lost five times in a row, the control enters one-hour lockout and fault codes “10” and “13” will be displayed alternately as described above (A-D).
4. When both the high pressure switch and low pressure switch are closed and both should be open (as in during the pressure switch proving period). In this case fault codes “44” and “55” will be displayed alternately as described above (A-D).
5. When the high pressure switch is open and the demand from the thermostat is set to 100% heat. . . In this case the operation code “h” (for low heat) and the fault code “57” (open high pressure switch) will be displayed alternately.
6. While the control is in one-hour lockout due to an unexpected flame, the fault codes “14” (unexpected flame) and “10” (soft lockout) will be displayed alternately as described above (A-D).
7. While the control has entered a one-hour lockout after declaring a dead blower after the main limit control has been open for more than 150 seconds, the fault codes “61” (non-operational blower) and “10” (soft lockout) will be displayed alternately as described above (A-D). **Note:** the dead blower fault and associated one-hour lockout will occur up to four times in one heat call. Upon declaring this fault for the fourth time in one heat call, the control will enter hard lockout.
8. While the control is in one-hour lockout due to sensing an inducer overcurrent condition, the fault codes “34” (inducer overcurrent) and “10” (soft lockout) will be displayed alternately at the seven-segment display as described above (A-D).
9. When the main limit has been open during a gas heat call for more than 150 seconds and has not yet re-closed, the fault codes “61” (non-operational blower) and “22” (open limit) will be displayed alternately as described above (A-D) until the limit re-closes.
10. When the water level sensor has declared a 1-hr lockout after declaring a **Water Sensed** condition (heating operation is shut down due to this fault) several times consecutively. When the control enters lockout the fault codes “59” (Water Sensed) and “10” (soft lockout) will be displayed alternately as described above (A-D).
11. When IFC is in soft lockout and fault “93” is active, the fault code “93” is to be displayed alternately with the fault code “10” as described above (A-D).
12. When gas valve is energized, flame is sensed and IFC detects a fault condition which will not prevent gas heating operation from continuing (like fault “57”, “12”, “66”), IFC will display the operation code “h” or “H” or “CL” alternately with the active fault code as described above (A-D).
13. During cold calibration sequence, if the low pressure switch make (close) RPM is greater than the high pressure switch make (close) RPM or, if the low pressure switch break (open) RPM is greater than the high

# INTEGRATED FURNACE CONTROL

## DUAL SEVEN SEGMENT DISPLAY

pressure switch break (open) RPM, the high and low pressure switches are assumed to be mis-wired such that the high pressure switch is connected to the wiring for the low pressure switch and vice-versa. In this case the fault code “45” (Low Pressure Switch Open, Inducer on High Speed) and “55” is to be displayed alternately as described above (A-D).

The fault and mode codes and fault priorities are listed below. Priority is to be used to determine which fault to display when two or more faults are present simultaneously.

**NOTE:** Verify display orientation is correct before interpreting fault codes. Otherwise, the fault codes may be upside-down. If a code is not on this list, the display may be upside-down.

### 15. PUSHBUTTON (S8)

#### Activation of IFC Status Menu

## PUSHBUTTON

The status mode is entered when the pushbutton is pressed for less than 2 seconds. While in the Status menu at the seven segment displays, the **CATEGORY FIELD** is displayed first for one second immediately followed by the appropriate value for one second. This cycle repeats until 60 seconds has expired or the pushbutton has been pushed again for less than 2 seconds. If the button is pressed again for less than 2 seconds within the 60 second period, the next **CATEGORY FIELD** will be displayed and the 60 second timer will be reset. After displaying all of the categories listed, the control will loop back to the first category when the button is pressed again for less than 2 seconds.

While in the **CATEGORY FIELD**, if the pushbutton is pressed for more than 2 seconds but less than 5 seconds, the display will exit the **CATEGORY FIELD** upon release of the pushbutton. Otherwise, the status menu will automatically exit if no activity is sensed on the pushbutton for 60 seconds.

The categories will be displayed in the following sequence:

Category	Information
FL	Up to six faults (Example: = 22-46-30=)
AF	IBM CFM (Example: 1251 = 12-51, 745 = 7-45)
Fr	Fire rate
UI	Furnace size (in thousands of Btu)
tr	Temperature Rise in Degrees F (example 55)*

\*If the Supply Air Temperature Sensor is not available, the category will not be displayed.

#### Fault history display (FL)

Up to 6 faults are stored in the buffer with the most recent replacing the oldest fault.

Unless otherwise specified, when a fault becomes active it is to be stored in non-volatile memory provided no more than three occurrences of any given fault code are already

stored in the fault buffer. If a fault occurs and there are already 3 occurrences of the same fault in the buffer, the current fault will replace the oldest of the same fault in the buffer but will become the most recent fault displayed.

Before updating the fault history the history will be examined for the previous most recent record. If the most recent record in the history is the same fault number but has a lower fault level than the new fault, then instead of adding the new fault to the buffer, the previous fault and level are replaced with the new fault and level. The time stamp will also be updated. This way, the existing fault will be updated but a new fault will not be added.

**Note:** In case of active dual faults – e.g. typical for pressure switch faults, where fault “57” and “45” can be active and become promoted at the same time – the mechanism from the previous paragraph can be omitted. IFC can add new records into the fault history instead of replacing the existing records if the active dual faults get promoted to the higher fault level.

Faults older than 168 powered hours will be automatically deleted from the fault buffer.

When fault recall is activated, the six most recent faults which have occurred within 1 week (168 powered hours) will be displayed on the seven segment display in succession from the most recent to the oldest.

When displaying fault codes stored in the buffer, the control will flash the A and D segments of the right SSD for ½ second to indicate the beginning of the fault recall. Each fault shall be displayed steady for one second followed by energizing the top segment (A or D depending on the position of the Display Orientation Dipswitch) of the least significant (right most) Seven-segment display for ½ second followed by the next fault displayed for one second. This cycle repeats until all faults in the buffer are displayed. After all of the faults are displayed, the control will again energize the A and D segment of the least significant S.S.D. for ½ second.

# INTEGRATED FURNACE CONTROL

## PUSHBUTTON

Fault Level	Priority	Fault Codes	DISPLAY CODES Description
2	0	30	Open Fuse
2	1	93	Internal Control Fault Detected
2	2	d 1	No Model Data
2	3	5B	No Blower Communications
2	4	5 1	Blower Fault -Motor Can NOT Run
2	5	7 1	Inducer Fault
2	6	26	Line and Neutral Reversed or Poor Ground
2	7	34	IDM Overcurrent
2	8	5B	Water Circuit Open
2	9	14	Flame Present With Gas Valve Off
2	10	33	Over Temperature Switch (RollOut) Open
2	11	23	Auxiliary Limit Switch Open
1,2	12	22	Main Limit Switch Open
2	13	77	No Gas Valve Feedback Signal
1,2	14	59	Water Sensed
2	15	10	One - Hour Lockout
2	16	44	Low Pressure Switch Closed, Should be Open
1,2	17	45	Low Pressure Switch Open, Inducer On High Speed
1,2	18	46	Low Pressure Switch Open, Inducer On Low Speed
2	19	55	High Pressure Switch Closed, Should Be Open
1,2	20	57	High Pressure Switch Open, Inducer on High Speed
1	21	1 1	Failed Ignition
1	22	13	Flame Lost after Established
1	23	55	Mid Pressure Switch Closed, Should be Open
1	24	57	Mid Pressure Switch Open, Should be Closed
1	25	55	Blower Cutback
1	26	50	Blower Fault -Blower Can Still Run
1	27	12	Low Flame Sense Current
0	28	C L	Calibration Sequence Active (cold/warm/postpurge)
0	29	H	Call for High Heat
0	30	h	Call for Low Heat
0	31	C	Call for High Cooling Present
0	32	c	Call for Low Cooling Present
0	33	c d	Low Cooling with Dehumidification Active
0	34	C d	High Cooling with Dehumidification Active
0	35	hP	Low Heat Pump Operation
0	36	HP	High Heat Pump Heating Operation
0	37	dF	Defrost Operation
0	38	F	Call for Fan Present
1	39	B2	Supply Air Sensor Fault
1	40	B4	Outdoor Air Sensor Fault
1	41	B 1	Return Air Sensor Fault
1	42	d4	No valid Model Data On Memory Card
1	43	d6	Horsepower Conflict On Memory Card
0	44	□	System Off, Standby Mode No Thermostat Call Or Errors
1	45	99	Remote Faults Resets Performed

**Note 1:** Fault level 0 = Status (No Fault), 1 = Warning, 2 = Critical Fault

**Note 2:** Multiple fault scenarios are displayed by priority. A lower number indicates a more critical fault. Most critical fault has priority=0.

Step	1	2	3	4
Info	CFM- "1000's" & "100's" place	delay	CFM- "ten's" and "one's" place	delay
Time (sec)	1	0.5	1	2
Example (1246)	"12"	Off	"46"	Off
Example (721)	"7" (right segment)	Off	"21"	Off

lowing sequence:

The sequence repeats until the status menu is exited or the pushbutton is pressed again.

### Fire rate display

Gas heat fire rate is displayed for 1 second as follows:

"0" is displayed when flame is not lit.

Current firing rate = 0% to 99% or HI displayed for 100% firing rate.

### Model BTU Capacity/1000

The furnace input BTU will be taken from the model data. Values less than 100 will be displayed as two digits (example 70 displayed as 70). Values of 100 or greater will be displayed as three digits. The most significant digit will be displayed for one second on the left SSD followed by the remaining two digits which are also displayed for one second. Example: 112 would be displayed as 1 followed by 12.

### Temperature Rise

Temperature rise is to be displayed as absolute value of (Supply Temp – Return Temp) clamped at the maximum of 99 degrees F. If the Supply air temp sensor is not available the category will not be displayed.

### Clearing Fault History

The fault buffer can be cleared with the pushbutton while the Fault History Display (FL) menu is active by holding down the pushbutton for 5 seconds or more. For indication that the fault buffer is clear the IFC will flash segments A and D of the right-most seven segment displays one second on and one second off three times after the fault clear command has been recognized.

## 16. SUPPLY AND OUTDOOR AIR TEMPERATURE SENSOR INPUTS (T4) see Figure 54

Optional field-installed supply air and outdoor air sensors (10K NTC thermistor) shall be read from the T4 screw terminal block.

Control to resolve temperature within +/-2°F at 70°F There is to be an automatic detection of the supply and outdoor air sensors. If the resistance between the terminals is within a valid 10K thermistor range (supply air temp range = -40°F to 200°F, outdoor air temp range = -40 to 200°F), both sensors temperatures will be accessible.

If the resistance between the supply air terminals is determined to be out of range to a high resistance, it shall be interpreted as an uninstalled supplied air sensor and shall not cause an error condition unless a valid thermistor value was previously sensed on the same power cycle. If the sensor was determined to be present and then is

# INTEGRATED FURNACE CONTROL

## SUPPLY AND OUTDOOR AIR TEMPERATURE SENSORS

opened the control should display a fault “82”. The fault is a level 1 fault and will not inhibit furnace operation. Also, if the resistance between the terminals is determined to be out of range to a low resistance and a valid thermistor value was sensed on the same power cycle, a fault “82” is to be displayed on the seven segment displays.

If the resistance between the outdoor air terminals (OAT) is determined to be out of range to a high resistance, it shall be interpreted as an uninstalled supplied outdoor air sensor and shall not cause an error condition unless a valid thermistor value was previously sensed on the same power cycle. If the sensor was determined to be present and then is opened, the control should display a fault “84”. The fault is a level 1 fault and will not inhibit furnace operation.

Also, if the resistance between the terminals on the OAT is determined to be out of range to a low resistance, a fault “84” is to be displayed on the seven segment displays only if a valid thermistor value was previously sensed on the same power cycle.

Fault codes “82” and “84” shall only be present for three minutes after the fault is detected. After three minutes has expired, the fault will no longer be set even if the condition creating the fault is still present. These faults are also only logged into the fault buffer one time. Should the sensor error later clear and then appear again the same sequence as noted previously will be repeated.

### 17. AUXILIARY INPUTS (COMMUNICATING SYSTEMS

#### ONLY) (T5) (SEE FIGURE 55)

Terminal T5 is provided for field installation of up to two auxiliary switches. The auxiliary inputs shall be used to provide a means of using traditional drain pan switches, smoke detectors, freeze switches, etc. The inputs are to be labeled **Aux 1** and **Aux 2**. The switch inputs are for communicating systems only. One or both inputs can be configured at the communicating thermostat as either normally-opened or normally closed contacts. System operation when the contacts either open or close can be configured at the communicating thermostat.

A resistance of greater than 1k ohms to common shall be detected as an open switch and a resistance of less than 100 ohms shall be recognized as a closed switch.

### 18. THERMOSTAT INPUTS (T2) – THERMOSTAT WIRING DIAGRAMS

Both communicating and legacy thermostats are to be connected at terminal block T2.

#### A. COMMUNICATING SYSTEMS

The furnace is capable of communicating with a thermostat and condenser to improve cooling and heat-pump airflow, displaying active faults and active furnace information at the thermostat and improved diagnostics and troubleshooting.

#### WIRING A FURNACE FOR COMMUNICATIONS.

# INTEGRATED FURNACE CONTROL

## THERMOSTAT INPUTS

**FIGURE 54**  
WIRING OF SUPPLY AIR (SA) AND OUTDOOR AIR (OAT) TEMPERATURE SENSORS

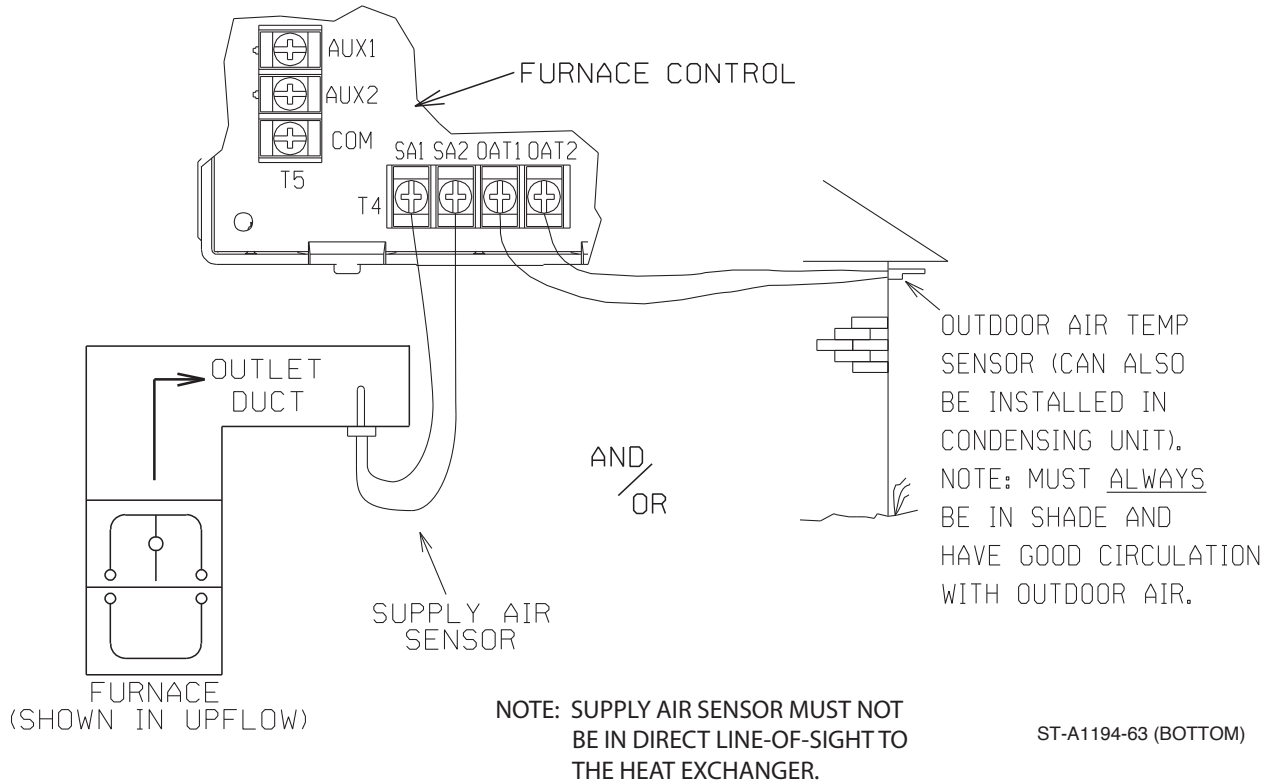

Integrated Furnace Control

Maximum wire lengths and notes about wiring communicating systems are noted below.

### MAXIMUM COMMUNICATING WIRE LENGTHS (E1, E2, R & C)

- Max Wire Length – Thermostat to Furnace = **125 FT @ 18 AWG\***
- Max Wire Length – Furnace to Condenser = **125 FT @ 18 AWG\***
- Max Wire Length – Between any 2 devices = **125 FT @ 18 AWG\***
- Sum Max Total Wire Length for All Components = 500 ft (see Figure 55)

#### Notes:

1. Wires may be solid or stranded.
2. \*Wire gage smaller than 18 AWG is not approved or recommended for this application.
3. If the thermostat wiring will be located near or in parallel with high voltage wiring, cable TV, Ethernet wiring, or radio frequency equipment, then shielded thermostat wire can be used to reduce or eliminate potential

interference. The shielding must be contiguous (have continuity) across all devices and all wire segments. This should be done by twisting the shielding wires from adjacent segments together. Further, the shielding for the entire system must be grounded in a single location. Multiple grounds on the shielding system are NOT permitted. The shield wire should be connected to the C terminal, or ground, at the indoor unit. The shield wire should NOT be connected to any terminal at the Control Center (aka; Thermostat). Connecting the shield to ground at both ends can cause current loops in the shield, reducing shield effectiveness.

4. When using existing wire from a previous installation, be sure to trim the tip of the wire back past the insulation and strip a small amount of insulation from the wire to expose clean new copper for the communicating connections. Fresh copper must be exposed when making the communicating connections or communications may not be properly established.

#### A. WIRING OF FULLY COMMUNICATING SYSTEMS.

# INTEGRATED FURNACE CONTROL

## AUXILIARY INPUTS

**FIGURE 55**  
WIRING OF AUXILIARY INPUTS (USE WITH COMMUNICATING SYSTEMS ONLY)

### WIRING DIAGRAM - OPTIONAL AUXILIARY INPUTS

NOTE: AUXILIARY INPUTS ARE ONLY MONITORED IN COMMUNICATING MODE.

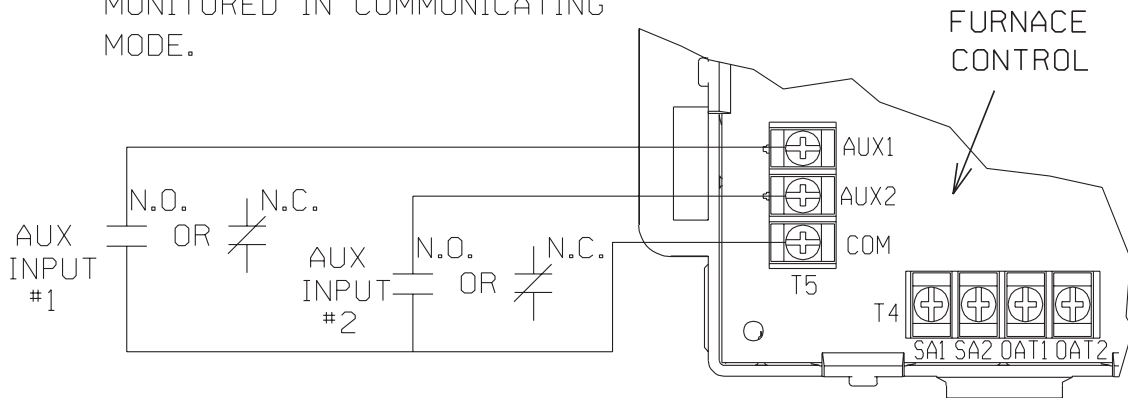

NOTE: EITHER A NORMALLY-OPENED (N.O.) OR NORMALLY-CLOSED (N.C) ACCESSORY CAN BE ATTACHED TO AUXILIARY INPUTS 1 AND/OR 2. SELECT CONFIGURATION (N.O. OR N.C.) AT THE COMMUNICATING THERMOSTAT.

ST-A1194-63 (TOP)

# INTEGRATED FURNACE CONTROL

## THERMOSTAT WIRING DIAGRAMS-COMMUNICATING

**FIGURE 56**  
WIRING DIAGRAM FOR A FULLY COMMUNICATING SYSTEM

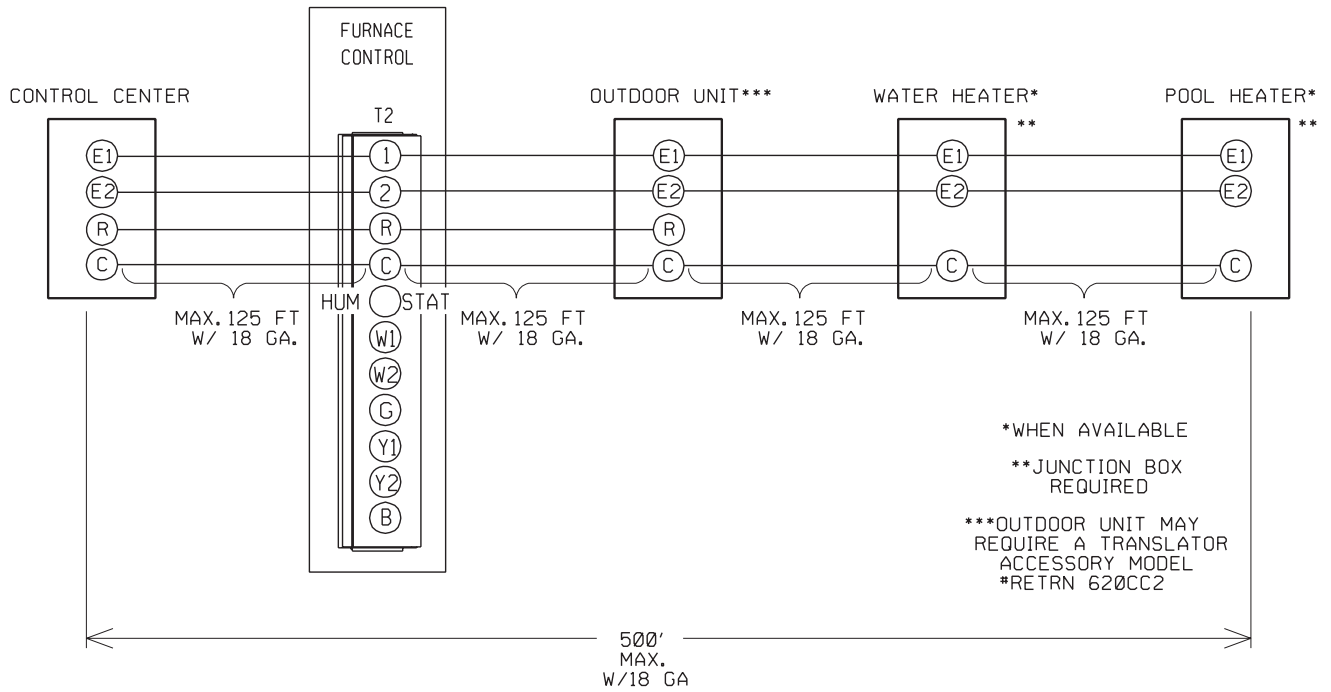

THIS IS THE ONLY APPROVED CONFIGURATION

ST-A1217-01

Figure 56 is the wiring diagram for connecting the furnace to an approved EcoNet communicating thermostat and approved EcoNet communicating condenser. The only approved configuration is to install dedicated wires directly from the furnace to the thermostat and a separate set of dedicated wires directly from the furnace to the condenser.

Additional EcoNet devices can be added to the system as

shown in Figure 56. The approved wiring configuration is the daisy-chain configuration shown in Figure 56. A star wiring configuration is not approved and should not be used.

**Note:** The only approved configuration requires that four dedicated wires (E1, E2, R and C) be installed from the furnace to the condenser.

### B. SPECIAL CONFIGURATION – WIRING OF

# INTEGRATED FURNACE CONTROL

## THERMOSTAT WIRING DIAGRAMS-CONDENSING UNIT (NON-COMMUNICATING)

**FIGURE 57**  
WIRING DIAGRAM FOR NON-COMMUNICATING CONDENSER UNIT WITH COMMUNICATING FURNACE AND THERMOSTAT

### A. WIRING DIAGRAM

SPECIAL CONFIGURATION:  
COMMUNICATING THERMOSTAT AND FURNACE  
WITH NON-COMMUNICATING CONDENSER  
(SINGLE - STAGE ONLY CONDENSER)

125 FEET MAX. @ 18 GA.

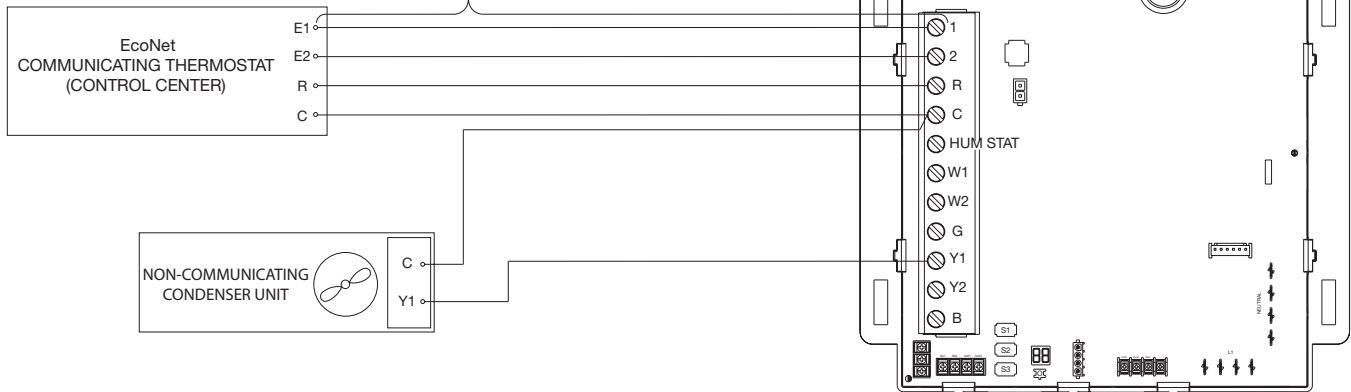

### B. WIRING DIAGRAM

SPECIAL CONFIGURATION:  
COMMUNICATING THERMOSTAT AND FURNACE  
WITH NON-COMMUNICATING CONDENSER  
(TWO - STAGE ONLY CONDENSER)

125 FEET MAX. @ 18 GA.

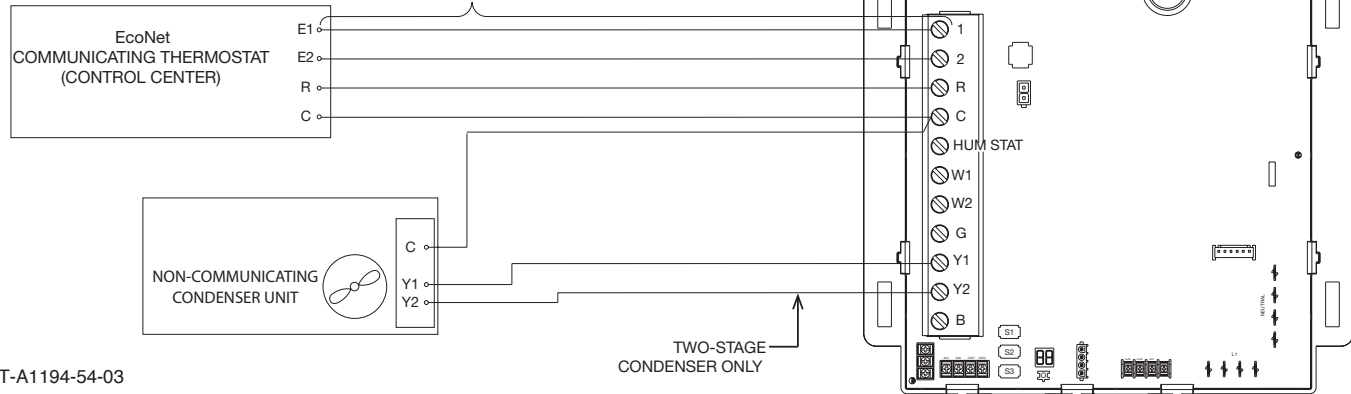

ST-A1194-54-03

NON-COMMUNICATING CONDENSERS WITH  
COMMUNICATING FURNACE AND THERMOSTAT  
(SEE FIGURE 57).

### C. CONDENSING SYSTEMS W/LEGACY THERMOSTAT



# INTEGRATED FURNACE CONTROL

## THERMOSTAT WIRING DIAGRAMS-CONDENSING UNIT (NON-COMMUNICATING)

**FIGURE 58**  
WIRING DIAGRAM FOR LEGACY SINGLE-STAGE THERMOSTAT WITH AUTOSTAGING

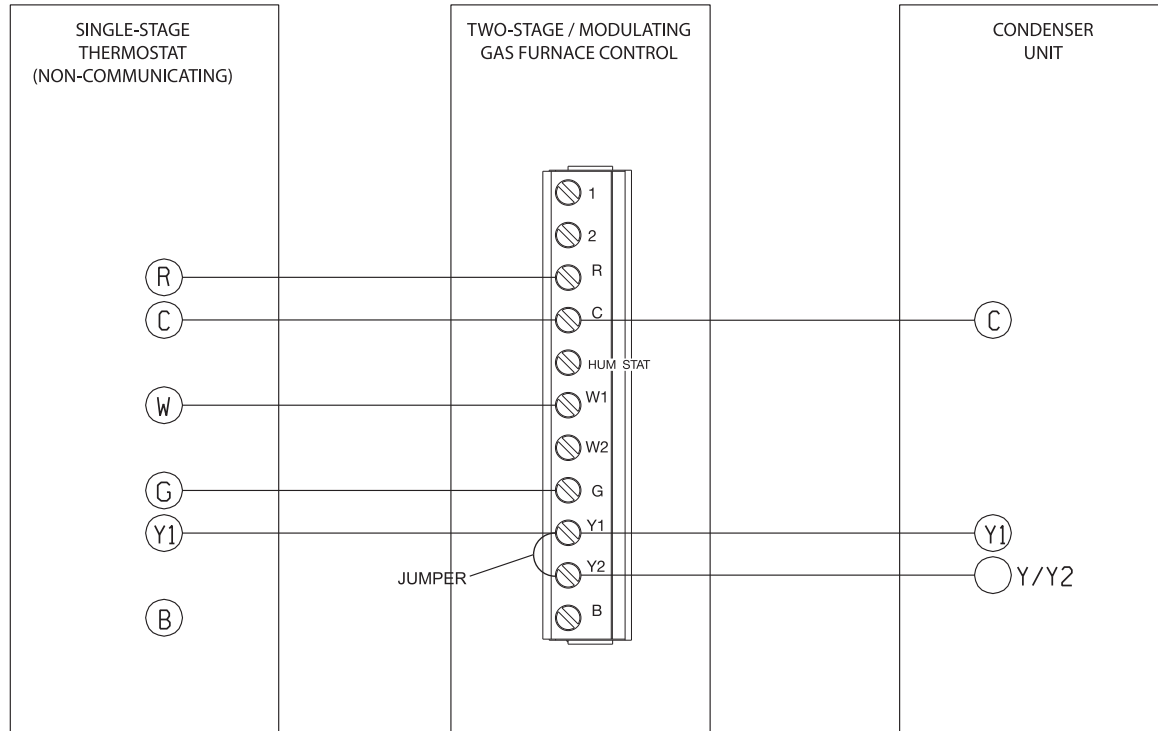

NOTE: 1.) FOR TIMED STAGING, THE DIPSWITCHES 10 AND 11 (S2-10 AND S2-11) MUST NOT BE LEFT IN THE "OFF" POSITION. IF THE SWITCHES ARE LEFT IN THE "OFF" POSITION WITH THIS CONFIGURATION, THE FURNACE WILL NEVER GET TO HIGH STAGE HEAT. (SEE DIPSWITCH SECTION OF THIS BOOK).

2.) FOR SINGLE STAGE COOLING A JUMPER BETWEEN Y1 AND Y2 IS REQUIRED.

ST-A1194-61-04

Integrated Furnace Control

C1. WIRING OF A 1-STAGE LEGACY THERMOSTAT WITH AUTOSTAGING SELECTED (SEE FIGURE 58).

C2. WIRING OF A 2-STAGE LEGACY THERMOSTAT (SEE FIGURE 59).

# INTEGRATED FURNACE CONTROL

## THERMOSTAT WIRING DIAGRAMS-CONDENSING UNIT (NON-COMMUNICATING)

**FIGURE 59**  
WIRING DIAGRAM FOR A LEGACY TWO-STAGE THERMOSTAT

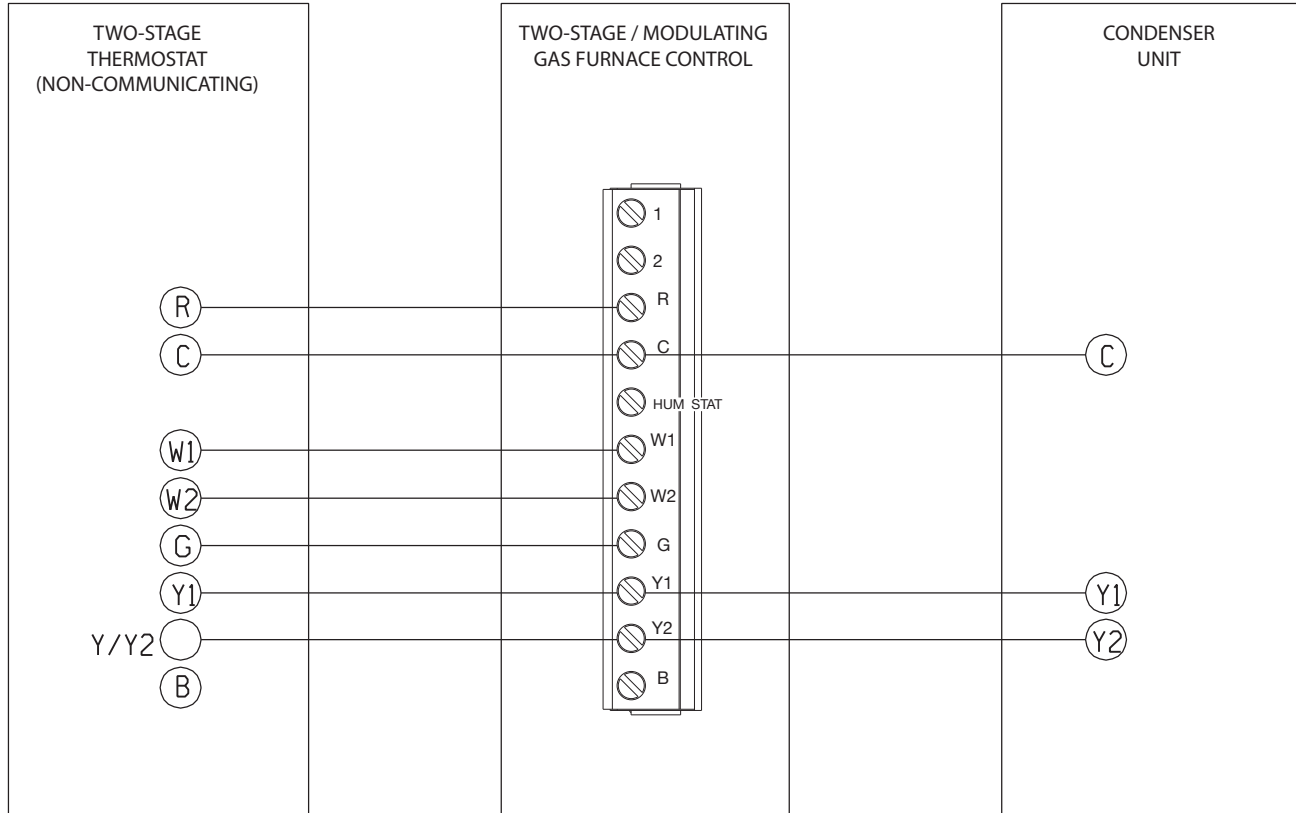

ST-A1194-62-04

Integrated Furnace Control

# INTEGRATED FURNACE CONTROL

## THERMOSTAT WIRING DIAGRAMS-CONDENSING UNIT (NON-COMMUNICATING)

**D. SPECIAL CONFIGURATION – WIRING OF  
NON-COMMUNICATING HEAT-PUMPS WITH  
COMMUNICATING FURNACE AND THERMOSTAT  
(SEE FIGURE 60).**

**FIGURE 60**  
WIRING DIAGRAM FOR NON-COMMUNICATING HEAT PUMPS WITH COMMUNICATING FURNACE AND THERMOSTAT

### A. WIRING DIAGRAM

SPECIAL CONFIGURATION:  
COMMUNICATING THERMOSTAT AND FURNACE  
WITH NON-COMMUNICATING HEAT PUMP  
(SINGLE - STAGE ONLY)

125 FEET MAX. @ 18 GA.

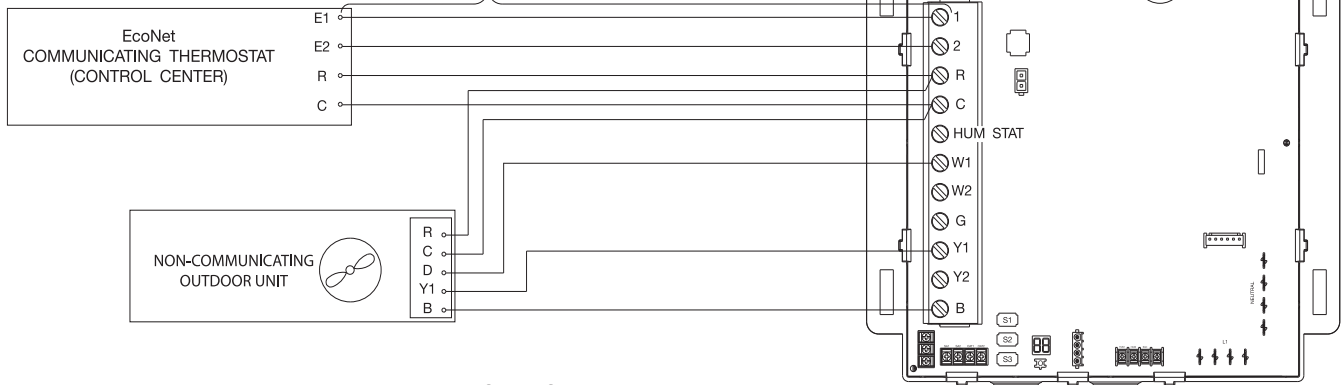

### B. WIRING DIAGRAM

SPECIAL CONFIGURATION:  
COMMUNICATING THERMOSTAT AND FURNACE  
WITH NON-COMMUNICATING HEAT PUMP  
(TWO - STAGE ONLY)

125 FEET MAX. @ 18 GA.

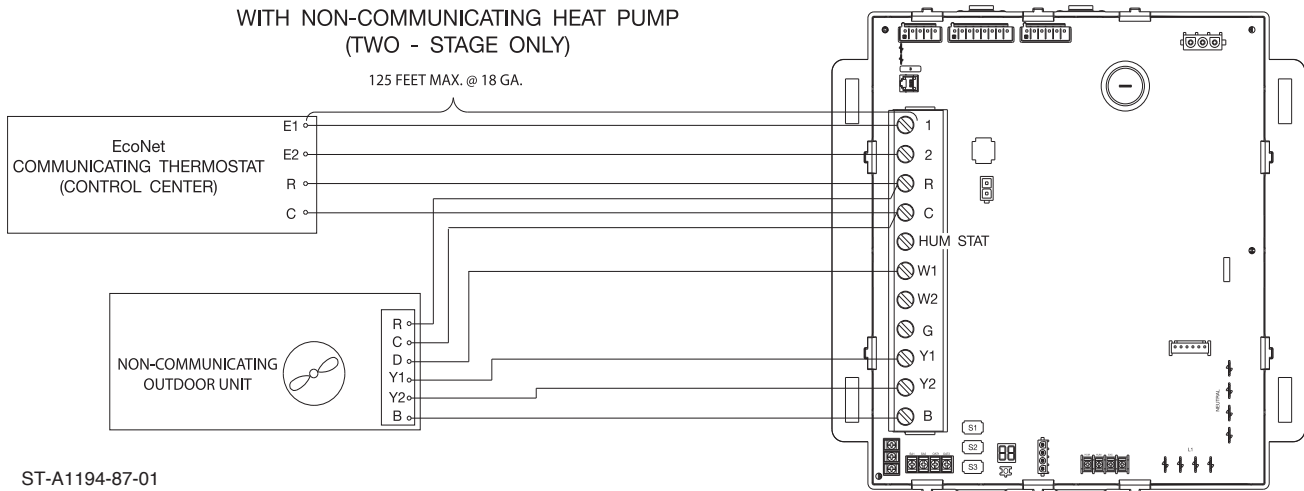

ST-A1194-87-01

Integrated Furnace Control

# INTEGRATED FURNACE CONTROL

## THERMOSTAT WIRING DIAGRAMS-CONDENSING UNIT (NON-COMMUNICATING)

### E. HEAT PUMP SYSTEMS W/LEGACY THERMOSTATS

E1. WIRING OF A SINGLE-STAGE LEGACY THERMOSTAT WITH AUTOSTAGING SELECTED (SEE FIGURE 61).

**FIGURE 61**  
WIRING DIAGRAM FOR A LEGACY SINGLE-STAGE THERMOSTAT WITH AUTOSTAGING.

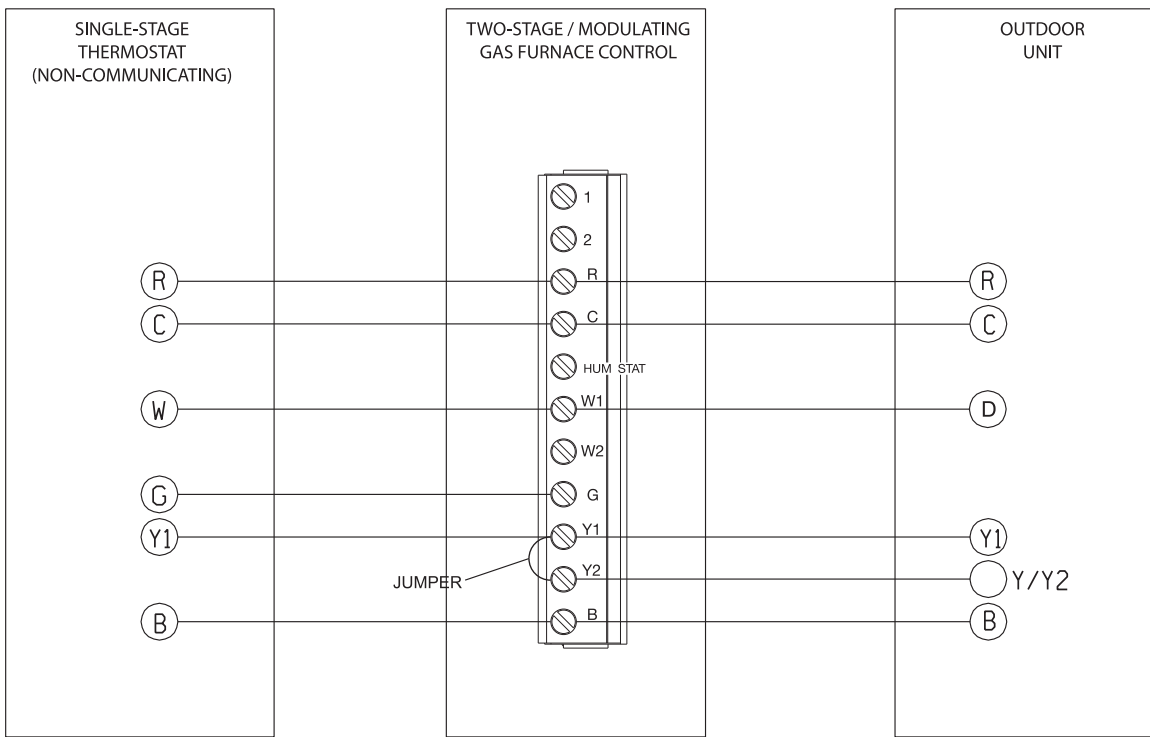

NOTE: 1.) FOR TIMED STAGING, THE DIPSWITCHES 10 AND 11 (S2-10 AND S2-11) MUST NOT BE LEFT IN THE "OFF" POSITION. IF THE SWITCHES ARE LEFT IN THE "OFF" POSITION WITH THIS CONFIGURATION, THE FURNACE WILL NEVER GET TO HIGH STAGE HEAT. (SEE DIPSWITCH SECTION OF THIS BOOK).

2.) FOR SINGLE STAGE COOLING A JUMPER BETWEEN Y1 AND Y2 IS REQUIRED.

ST-A1194-92-01

# INTEGRATED FURNACE CONTROL

## THERMOSTAT WIRING DIAGRAMS-CONDENSING UNIT (NON-COMMUNICATING)

E2. WIRING OF A TWO-STAGE LEGACY THERMOSTAT (SEE FIGURE 62).

**FIGURE 62**  
WIRING DIAGRAM FOR A LEGACY 2-STAGE THERMOSTAT

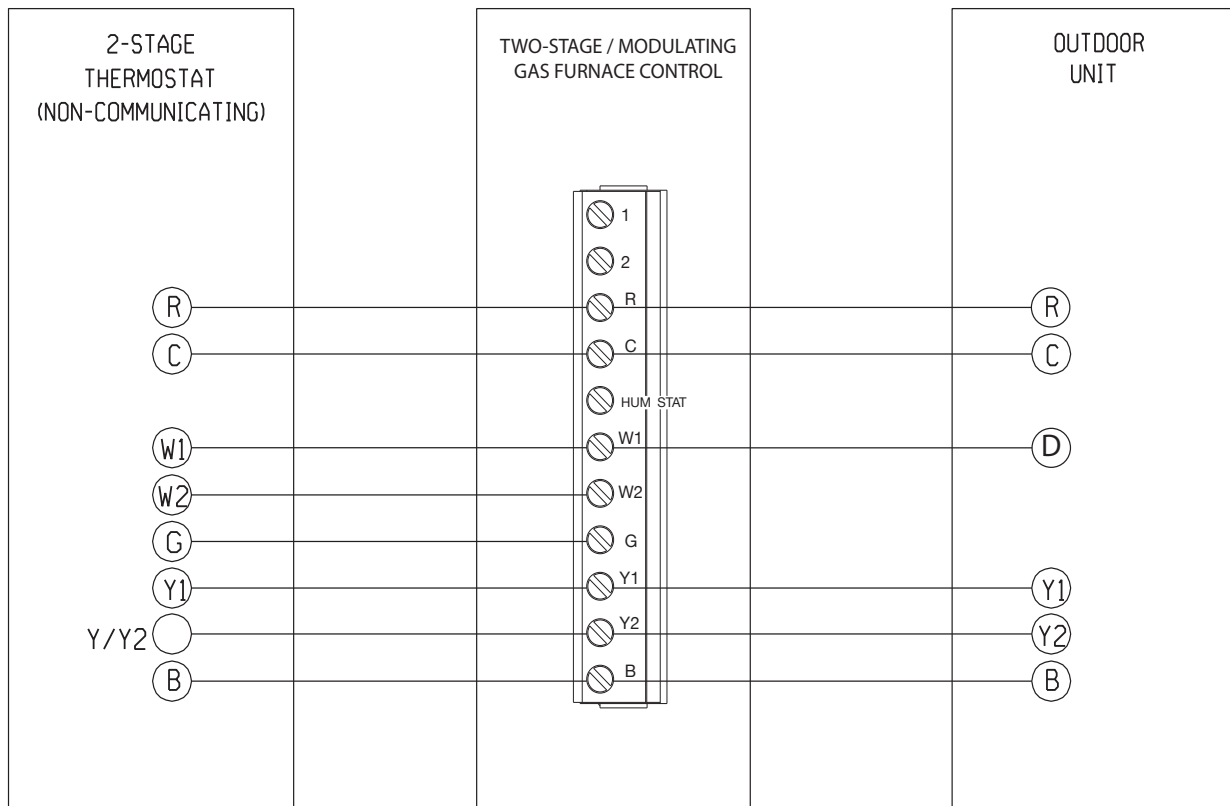

ST-A1194-93-01

Integrated Furnace Control

### 19. 24VAC AND COMMON CONNECTIONS (E10/E11)

For connection to the low voltage side of the control transformer. Terminals are ¼" quick-connect style.

### 20. FUSE (P100/P101)

A fuse is provided to protect low-voltage (24VAC) circuits from shorts between 24VAC and Ground or Common. A fault code 30 is displayed at the furnace control when the fuse has been opened.

# TIMING DIAGRAM

TABLE 16  
TIMING DIAGRAM FOR A CALIBRATION GAS HEAT SEQUENCE

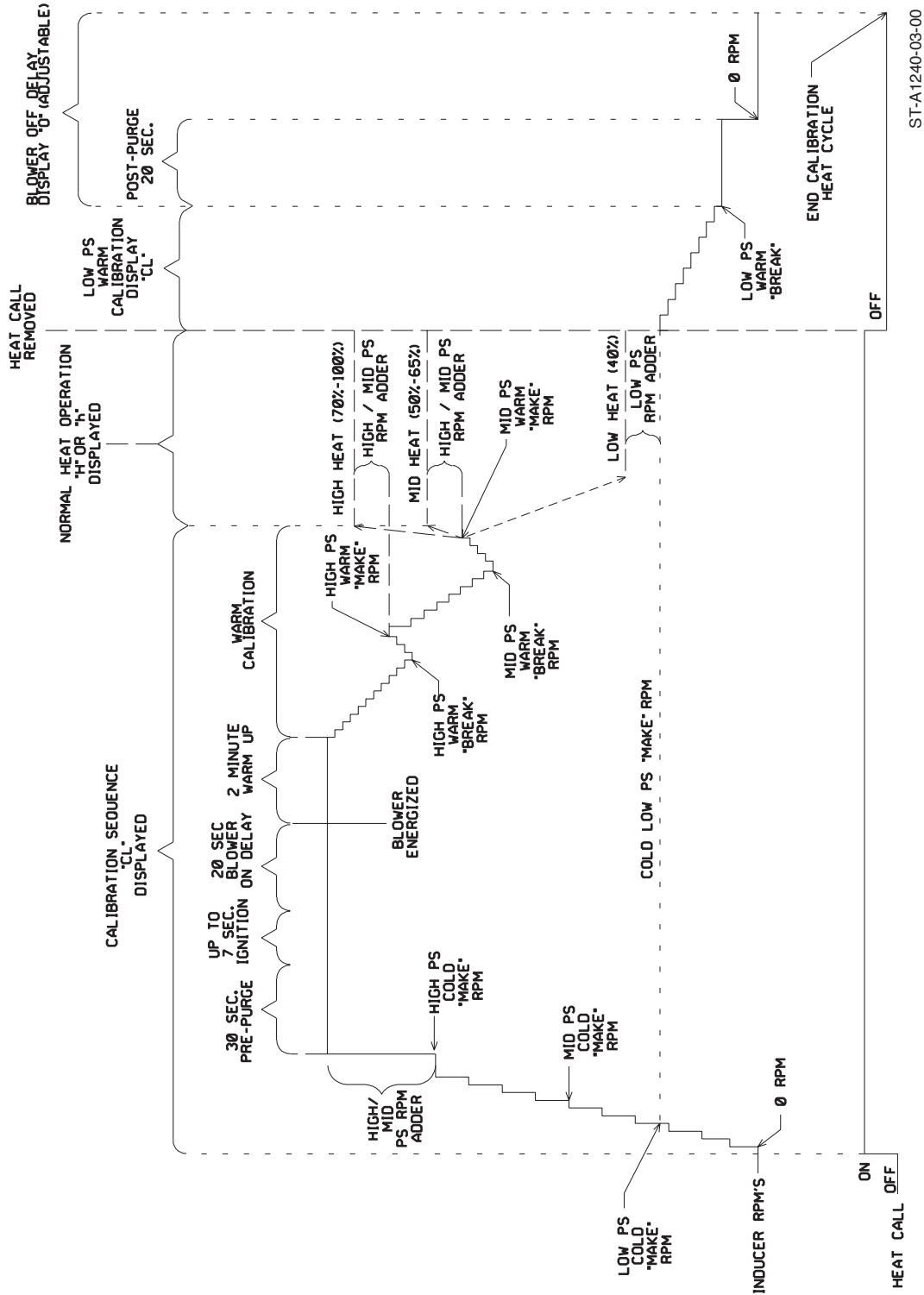

# TIMING DIAGRAM

**TABLE 17**  
TIMING DIAGRAM FOR NON-CALIBRATION GAS HEAT SEQUENCE

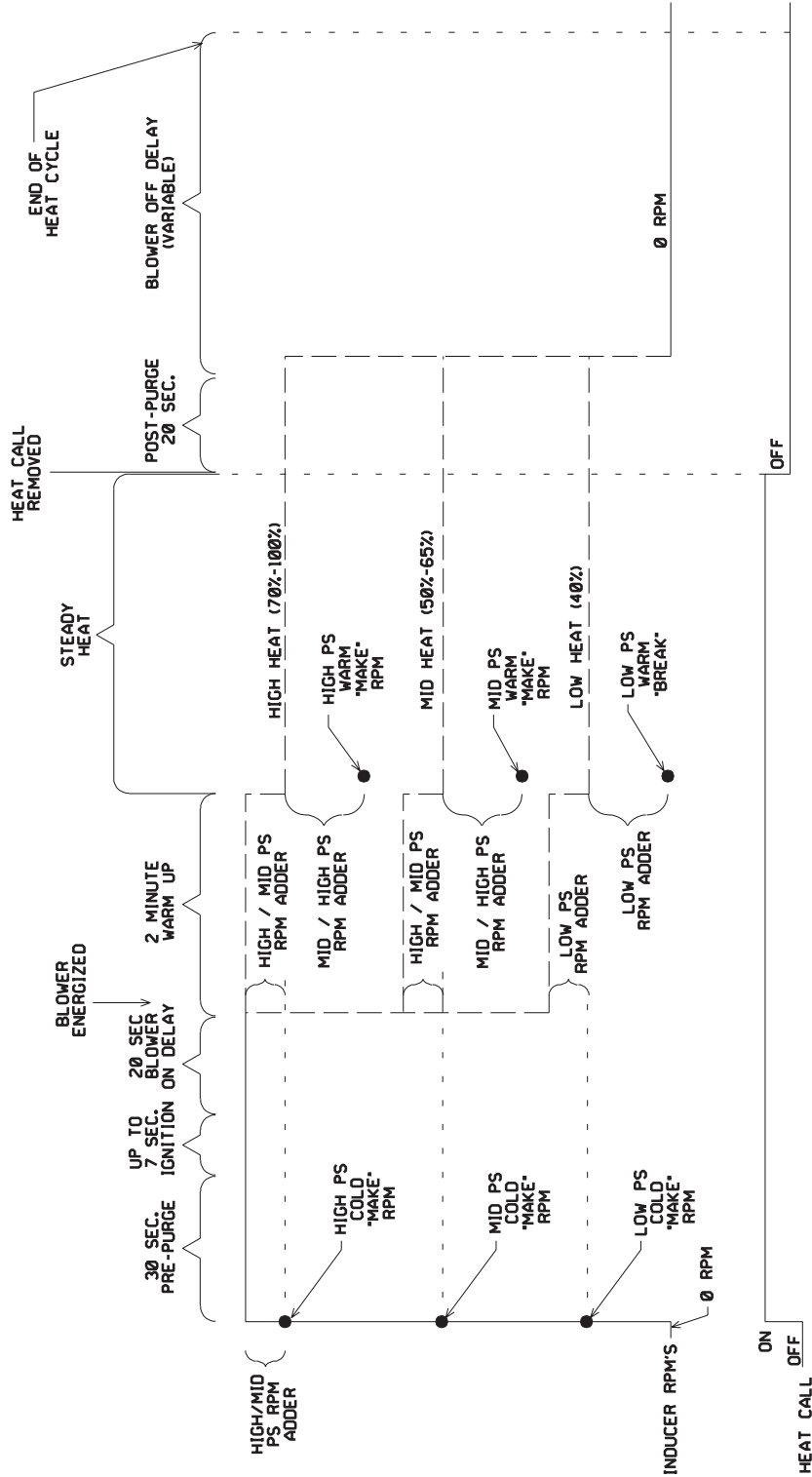

ST-A1240-04-00

# MAINTENANCE

## MAINTENANCE

### WARNING

THESE INSTRUCTIONS ARE INTENDED AS AN AID TO QUALIFIED SERVICE PERSONNEL FOR PROPER INSTALLATION, ADJUSTMENT AND OPERATION OF THIS UNIT. READ THESE INSTRUCTIONS THOROUGHLY BEFORE ATTEMPTING INSTALLATION OR OPERATION. FAILURE TO FOLLOW THESE INSTRUCTIONS MAY RESULT IN IMPROPER INSTALLATION, ADJUSTMENT, SERVICE OR MAINTENANCE, POSSIBLY RESULTING

IN FIRE, ELECTRICAL SHOCK, CARBON MONOXIDE POISONING, EXPLOSION, PROPERTY DAMAGE, PERSONAL INJURY OR DEATH.

DISCONNECT MAIN ELECTRICAL POWER TO THE UNIT BEFORE ATTEMPTING ANY MAINTENANCE. FAILURE TO DO SO CAN CAUSE ELECTRICAL SHOCK RESULTING IN PERSONAL INJURY OR DEATH.

## FILTERS

### CAUTION

DO NOT OPERATE THE SYSTEM FOR EXTENDED PERIODS WITHOUT FILTERS. A PORTION OF THE DUST ENTRAINED IN THE AIR MAY TEMPORARILY LODGE IN THE AIR DUCT RUNS AND AT THE SUPPLY REGISTERS. ANY RECIRCULATED DUST

PARTICLES WILL BE HEATED AND CHARRED BY CONTACT WITH THE FURNACE HEAT EXCHANGER. THIS RESIDUE WILL SOIL CEILINGS, WALLS, DRAPES, CARPETS AND OTHER HOUSEHOLD ARTICLES.

## LUBRICATION

**IMPORTANT: DO NOT** attempt to lubricate the bearings on the blower motor or the induced draft blower motor. Addition of lubricants can reduce the motor life and void the warranty.

The blower motor and induced draft blower motor are permanently lubricated by the manufacturer and do not require further attention.

It is recommended that the blower motor and induced draft blower motor be cleaned periodically by a qualified installer, service agency, or the gas supplier to prevent the possibility

of overheating due to an accumulation of dust and dirt on the windings or on the motor exterior. And, as suggested elsewhere in these instructions, the air filters should be kept clean. Dirty filters can restrict airflow. The motor depends upon sufficient air flowing across and through it to keep from overheating.



## SYSTEM OPERATION INFORMATION

### ADVISE THE CUSTOMER

1. Keep the air filters clean. The heating system will operate better, more efficiently and more economically.
2. Arrange the furniture and drapes so that the supply air registers and the return air grilles are unobstructed.
3. Close doors and windows. This will reduce the heating load on the system.
4. Avoid excessive use of kitchen exhaust fans.
5. Do not permit the heat generated by television, lamps or radios to influence the thermostat operation.
6. Except for the mounting platform, keep all combustible articles 3 feet from the furnace and vent system.
7. **IMPORTANT:** Replace all blower doors and compartment covers after servicing the furnace. Do not operate the unit without all panels and doors securely in place.
8. Explain the advantages of continuous fan operation to the customer.

### ANNUAL INSPECTION

- The furnace should operate for many years without excessive scale build-up in the flue passageways. However, it is recommended that a qualified installer, service agency, or the gas supplier annually inspect the flue passageways, the vent system and the main burners for continued safe operation. Pay particular attention to deterioration from corrosion or other sources.
- **IMPORTANT:** It is recommended that at the beginning and at approximately half way through the heating season, a visual inspection be made of the main burner flames for the desired flame appearance by a qualified installer, service agency or the gas supplier. If the flames are distorted and/or there is evidence of back pressure, check the vent and inlet air system for blockage. If there is carbon and scale in the heat exchanger tubes, the heat exchanger assembly should be replaced.
- **IMPORTANT:** It is recommended that at the beginning of the heating season, the flame sensor be cleaned with fine steel wool or Scotch Bright Pad by a qualified installer, service agency or the gas supplier.
- **IMPORTANT:** It is recommended that at the beginning of the heating season, the condensate trap be inspected for debris or blockage. A blocked condensate trap can cause water to back up into the primary heat exchanger and lead to nuisance tripping of the overtemperature switches.
- **IMPORTANT:** It is recommended that at the beginning of the heating season, the condensate neutralizer if used be replaced by a qualified installer, service agency or the gas supplier.
- **IMPORTANT:** It is recommended that an annual inspection and cleaning of all furnace markings be made to assure legibility. Attach a replacement marking, which can be obtained through the distributor, if any are found to be illegible or missing.

#### **WARNING**

**HOLES IN THE VENT PIPE OR HEAT EXCHANGER CAN CAUSE TOXIC FUMES TO ENTER THE HOME, RESULTING IN CARBON MONOXIDE POISONING OR DEATH. THE VENT PIPE OR HEAT EXCHANGER MUST BE REPLACED IF THEY LEAK.**

### REPLACEMENT PARTS

Please contact the local distributor for replacement parts information.

# DIAGNOSTICS AND TROUBLESHOOTING

## DETAILS OF BURNER FACE-IGNITOR ELECTRODE RELATIONSHIP (MODULATING FURNACE ONLY)

The tip of the positive electrode must be inside the hatched area. .201 dimension from electrode to burner face must be maintained. Delayed ignition can result if these dimensions are not observed.

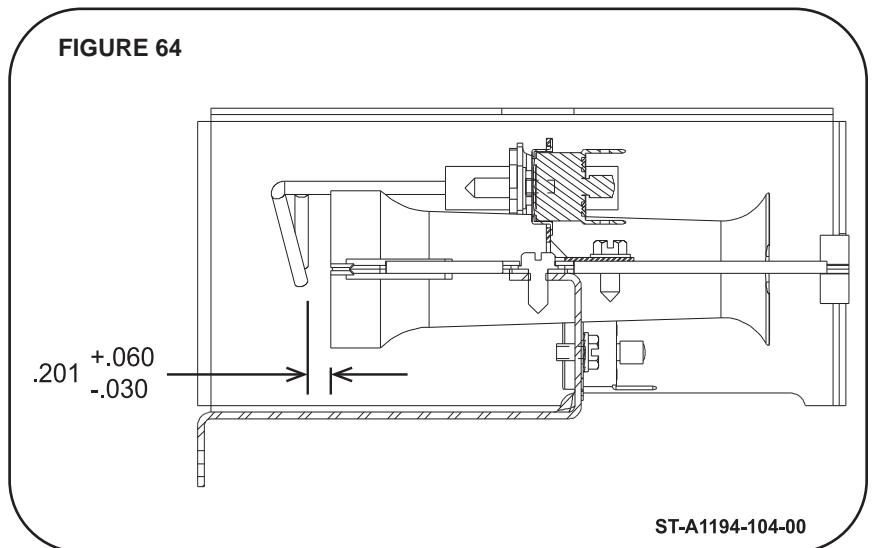
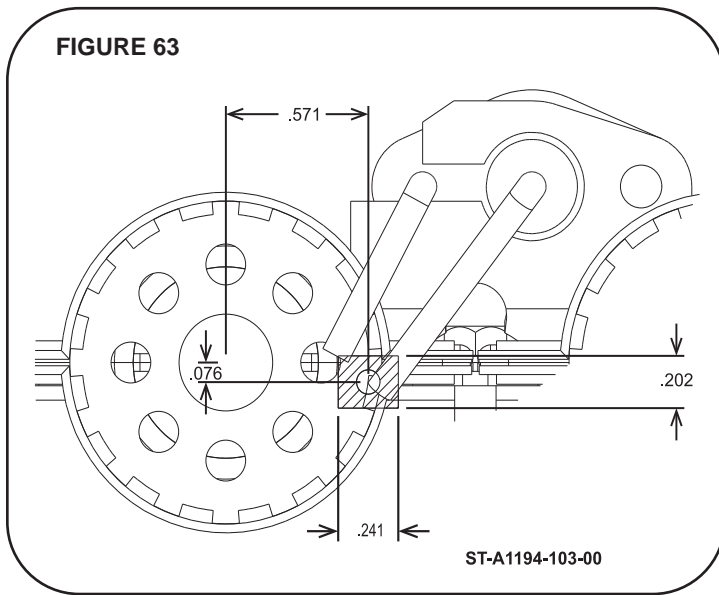

# FAULT CODES

Below are two lists; a list of standard operating codes and a list of fault codes. The fault code list provides diagnostic and troubleshooting information to help determine the problem and fix it. Standard operating codes are not fault codes and the presence of a standard operating code indicates a no-fault condition.

**NOTE:** Verify display orientation is correct before interpreting fault codes. Otherwise, the fault codes may be upside-down. If a fault code or operating code is not on these lists, the display may be upside-down.

**TABLE 18**  
98% MODULATING FURNACE NORMAL OPERATION CODES

## NORMAL OPERATION CODES

Key

CODE DISPLAYED AT DUAL SEVEN- SEGMENT DISPLAY OF CONTROL	NAME
	<u>DESCRIPTION</u>

### NORMAL OPERATION CODE

<b>0</b>	<b>STANDBY MODE</b> <b>DESCRIPTION:</b> This code is displayed anytime there is no fault present and no thermostat call present. The furnace is idle.
<b>H or h</b>	<b>GAS HEAT MODE</b> <b>DESCRIPTION:</b> This code is displayed anytime there is a call for gas heat. The lower-case "h" is displayed when the thermostat is requesting low gas heat and the upper-case "H" is displayed when the thermostat is requesting high-stage gas heat.
<b>C or c</b>	<b>COOLING MODE</b> <b>DESCRIPTION:</b> This code is displayed anytime there is a call for cooling. The lower-case "c" is displayed when the thermostat is requesting low-stage cooling and the upper-case "C" is displayed when the thermostat is requesting high-stage cooling.
<b>HP or hP</b>	<b>HEAT-PUMP HEATING MODE</b> <b>DESCRIPTION:</b> This code is displayed anytime there is a call for heat-pump heat. The lower-case "hP" is displayed when the thermostat is requesting low-stage heat-pump heat and the upper-case "HP" is displayed when the thermostat is requesting high stage heat-pump heat.
<b>F</b>	<b>CONTINUOUS FAN MODE</b> <b>DESCRIPTION:</b> This code is displayed anytime there is a call for continuous fan from the thermostat.
<b>dF</b>	<b>DEFROST MODE</b> <b>DESCRIPTION:</b> This code indicates that the heat-pump is in defrost mode (dual-fuel systems only) and furnace is operating for defrost operation which is fixed at low-stage gas heating operation.
<b>Cd or cd</b>	<b>COOLING IN DE-HUMIDIFICATION MODE</b> <b>DESCRIPTION:</b> This code indicates that there is a both cooling and dehumidification demand present at the same time. When de-humidification is active, the cooling airflow will be reduced in order to allow water to accumulate on the condenser thereby removing humidity from the conditioned environment. The lower-case "cd" is displayed when the thermostat is requesting low-cooling with de-humidification and the upper-case "Cd" is displayed when the thermostat is requesting high-stage cooling with de-humidification.

**TABLE 19**  
**98% MODULATING FURNACE FAULT CODES WITH DESCRIPTIONS AND SOLUTIONS**

**FAULT CODES**

Key

<b>FAULT CODE          DISPLAYED          AT DUAL          SEVEN-          SEGMENT          DISPLAY OF          CONTROL</b>	<b>DISPLAYED TEXT</b>
	<b>STATUS</b>
	<b>DESCRIPTION</b>
	<b>EXPECTED OPERATION</b>
	<b>CAUSE</b>
	<b>SOLUTION</b>

**FAULT CODES**

<b>NO MODEL DATA</b>	
<b>d1</b>	<b>STATUS:</b> This is a critical fault. The furnace will not operate in any mode.
	<b>DESCRIPTION:</b> This code is displayed anytime there is no model data at the furnace. The model data is electronically stored data that is used to define (among other things) blower operation. Without the model data, the furnace cannot function. Note that model data may be available even if there is no card attached to the furnace control. A missing memory card will display fault code "d4" if model data is available on the network.
	<b>EXPECTED OPERATION:</b> No operation (including thermostat) will be permitted without the model data. The model data defines the IBM (Indoor Blower Motor) speed-torque curve. Without this information, the IBM can not operate. Refer to the section of this manual titled "INTEGRATED FURNACE CONTROL" under the subsection titled "MODEL DATA CARD" for details on the hierarchy of use of multiple copies of model data and distribution (among other details) of model data.
	<b>CAUSE:</b> Typically, the model data card will be missing from the furnace. In most cases, the cause of this fault will be the loss or disconnection of the original model data card from the furnace control (or I.F.C.). When the furnace control (or I.F.C.) is replaced, the model data card must be saved and installed in the replacement control.
	<b>SOLUTION:</b> Replace the missing model data card into the connector labeled P6 on the furnace control (I.F.C.). If the original card can not be found, a replacement card can be ordered from ProStock. Be sure to order the correct model data card for the furnace. Note: Furnace power must be cycled off and then on again after replacing the card or the model data will not be read.
<b>NO VALID MODEL DATA ON MODEL DATA CARD</b>	
<b>d4</b>	<b>STATUS:</b> This is a non-critical fault. The furnace should operate in any mode.
	<b>DESCRIPTION:</b> The model data card inserted into the slot at position P6 of the furnace control is corrupt and can not be used OR there is no model data card installed at all. However, a valid copy of model data for the furnace still resides in the furnace microprocessor.
	<b>EXPECTED OPERATION:</b> Model data from the model data card cannot be used because it is invalid or not present at all. Operation should proceed as normal with this fault (d4) only being displayed during the standby mode.
	<b>CAUSE:</b> This fault is displayed when there is no information on the model data card (blank), the card is not present or the model data card has corrupted and cannot be properly read.
	<b>SOLUTION:</b> Remove the model data card and replace with the <i>original</i> memory card from the furnace or the <i>correct</i> replacement memory card. <b>Never replace the model data card of a furnace with a model data card from another furnace or component (e.g. condenser or air handler). Doing so could result in improper operation of the blower which may cause damage to the heat exchanger. If the original model data card for the furnace control is available and working, it must be used.</b> A correct replacement memory card can be ordered from ProStock. Be sure to have the furnace model and serial number available when ordering.
<b>HORSEPOWER CONFLICT ON MODEL DATA CARD</b>	
<b>d6</b>	<b>STATUS:</b> This is a non-critical fault. The furnace should operate in any mode.
	<b>DESCRIPTION:</b> The horsepower reported by the motor does not match the horsepower stored in memory in the model data of the model data card. However, the model data stored on the microprocessor of the furnace control does match the attached motor.
	<b>EXPECTED OPERATION:</b> Model data from the model data card cannot be used because it is invalid. Operation should proceed as normal with this fault (d6) only being displayed during the standby mode.
	<b>CAUSE:</b> There are two possible causes for this fault: (1) The blower motor has recently been replaced and the wrong horsepower motor was used. (2) The model data card or furnace control has recently been replaced and the wrong card or replacement control was used.
	<b>SOLUTION:</b> Determine the correct motor and/or model data card for the furnace and replace the incorrect or damaged part with a new, correct part. <b>Never replace the model data card of a furnace with a model data card from another furnace or component (e.g. condenser or air handler). Doing so could result in improper operation of the blower which may cause damage to the heat exchanger. If the original model data card for the furnace control is available and working, it must be used.</b> A correct replacement model data card can be ordered from ProStock. Be sure to have the furnace model and serial number available when ordering.

**TABLE 19 (continued)**  
**98% MODULATING FURNACE FAULT CODES WITH DESCRIPTIONS AND SOLUTIONS**

<b>10</b>	<b>ONE-HOUR LOCKOUT</b>
	<b>STATUS:</b> This is a critical fault. The furnace will not operate in gas heat modes but all other modes (e.g. cooling) should function.
	<b>DESCRIPTION:</b> This fault is displayed under the following conditions:
	1. When a failed ignition has occurred four times in a row, the control enters one-hour lockout and fault codes "10" and "11" will be displayed alternately at the seven-segment display. See fault code 11 for a description on expected operation, causes and solutions for this fault code.
	2. After declaring a Water Sensed condition (heating operation is shut down due to this fault) several times consecutively. When the control enters lockout the fault codes "59" (Water Sensed) and "10" (soft lockout) will be displayed alternately at the seven-segment display. See fault code 59 for a description on expected operation, causes and solutions for this fault code.
	3. While the control has entered a one-hour lockout after declaring a dead blower after the main limit control has been open for more than 150 seconds, the fault codes "61" (Non-operational blower) and "10" (soft lockout) will be displayed alternately at the seven-segment display. Note: the dead blower fault and associated one-hour lockout will occur up to four times in one heat call. Upon declaring this fault for the fourth time in one heat call, the control will enter hard lockout requiring manual reset of power to the furnace. See fault code 61 for a description on expected operation, causes and solutions for this fault code.
	4. When IFC is in soft lockout and fault "93" is active, the fault code "93" is to be displayed alternately with the fault code "10" at the furnace seven-segment display. See fault code 93 for a description on expected operation, causes and solutions for this fault code.
5. When flame is lost five times in a row, the control enters one-hour lockout and fault codes "10" and "13" will be displayed alternately at the IFC seven-segment display. See fault code 13 for a description on expected operation, causes and solutions for this fault code.	
6. While the control is in one-hour lockout due to an unexpected flame, the fault codes "14" (unexpected flame) and "10" (soft lockout) will be displayed alternately at the furnace seven-segment display. See fault code 14 for a description on expected operation, causes and solutions for this fault code.	
<b>11</b>	<b>FAILED IGNITION</b>
	<b>STATUS:</b> Up to three failed ignitions will not constitute a critical condition. Critical condition (with no heating operation) is only noted when the furnace has failed to ignite four or more times consecutively. After four failed ignition attempts, the IFC enters one-hour lockout and the dual faults "11" and "10" are alternately displayed at the IFC's seven-segment display.
	<b>DESCRIPTION:</b> This fault is displayed at the furnace control after the first failed ignition attempt. It continues to be displayed until successful ignition or the furnace control has failed to ignite four consecutive times. After four attempts, the status of the fault is elevated to "10" and the furnace control (or I.F.C.) reacts as described under description for the fault code "10". Note: This fault will not be displayed to the homeowner on communicating systems unless it occurs at least three times within a single heat call. It will not be displayed to the homeowner after the first or even second failure. However, it will be displayed in the active fault screen of thermostat immediately after the first failure (and all subsequent failures) during a single heat call. Further, this fault (11) will only be logged into the fault buffer one time. It will not log more than once in the buffer.
	<b>EXPECTED OPERATION:</b> After the first failed ignition attempt, the fault ("11") is displayed and the inducer will complete a 20 second post-purge followed by a second ignition attempt. This cycle will be repeated until gas heat is established or until the fourth failed ignition attempt. After the fourth failed attempt, the furnace control (IFC) will proceed to one-hour lockout.
	<b>CAUSE:</b> There can be several causes for a failed ignition attempt(s). The most common are: (1) The flame sense rod is unable to sense flame. It may need cleaning or may not be properly connected. (2) The gas valve may be turned off. (3) The igniter is not working properly. It may not be properly connected or the spark location may not be correct. (4) The furnace control may not be working properly and may need to be replaced. (5) The flame may not be properly spreading from the first burner to the last.
	<b>SOLUTION:</b> The solution will depend on the cause. Solutions to noted causes (1) through (5) above are: (1) Clean or replace the flame sense rod or check all connections and wire between the rod and the furnace control (or I.F.C.). Make sure furnace ground is properly connected. (2) Turn the valve on. (3) Replace or reposition the igniter or check all connections and wire between the igniter and the furnace control (or I.F.C.). (4) Replace the furnace control. (5) Check the manifold pressure during ignition. For natural gas it should be approx. 3.5" wc and for LP gas it should be approx. 10" wc. If manifold pressure is good, watch the burner during ignition. If the first burner lights, but the second, third and so on do not light, the burner may need to be replaced.

**TABLE 19 (continued)**  
**98% MODULATING FURNACE FAULT CODES WITH DESCRIPTIONS AND SOLUTIONS**

<b>12</b>	<b>LOW FLAME SENSE</b>
	<b>STATUS:</b> The status of this fault is non-critical and furnace operation will continue as normal in heating (and all other) mode(s). If flame sense is low, the furnace control (or I.F.C.) may soon no longer be able to properly sense the flame and status of the problem may be elevated to the level of fault code "13" or fault "11" (if flame can not be sensed at all).
	<b>DESCRIPTION:</b> The flame sense current from the flame sense rod at the furnace control (or I.F.C.) is weak or marginal at best.
	<b>EXPECTED OPERATION:</b> All operation (including gas heat) will proceed as normal with only the fault code ("12") displayed at the furnace control (I.F.C.) and "LO FLAME SENSE" displayed in the fault area of a communicating thermostat.
	<b>CAUSE:</b> (1) The most common cause for low flame sense during heat operation is that the flame sense rod may need cleaning or may not be properly connected or wiring between the rod and the furnace control may be shorted or opened.  (2) Another cause for low flame may be an improperly mounted or poorly grounded flame sensor.
	<b>SOLUTION:</b> (1) Clean or replace the flame sense rod or check all connections and wire between the rod and the furnace control (or I.F.C.).  (2) Reinstall or replace flame sensor and check wiring and connections. Also make sure the furnace is properly grounded.
<b>13</b>	<b>FLAME LOST AFTER ESTABLISHED</b>
	<b>STATUS:</b> Flame loss is not a critical fault. Subsequent ignition attempts will follow and normal operation should resume. However, a lost flame can often be followed by failed ignition attempts then a one-hour lockout. Once the status has reached one-hour lockout, the fault condition is critical (although attempts at ignition will be made again after the 1 hour lockout).
	<b>DESCRIPTION:</b> After a successful ignition trial, the flame (which was properly sensed) is no longer sensed. This can happen any time after successful ignition while a valid heat call is present.
	<b>EXPECTED OPERATION:</b> When flame is lost, the fault code ("13") is immediately displayed at the IFC SSD's. The IBM (Indoor Blower Motor) is energized (if it was not already) at the correct speed (based on the demand from the thermostat) and completes a 90 second blower off delay. The IDM (Induced Draft Motor) remains energized at the most recent speed (based on the demand from the thermostat or as required for ignition cycle) for a 20 second post-purge. After both the post-purge and blower off delay are complete, the fault code ("13") is removed and a new attempt at ignition is made. Often, the new ignition attempt will fail and operation will proceed as though a failed ignition has occurred from that point (see fault code "11"). Note: This fault will not be displayed to the homeowner on communicating systems unless it occurs at least three times within a single heat call. It will not be displayed to the homeowner after the first or even second failure. However, it will be displayed in the active fault screen of thermostat immediately after the first failure (and all subsequent failures) during a single heat call. Further, this fault (13) will only be logged into the fault buffer one time. It will not log more than once in the buffer.
	<b>CAUSE:</b> (1) The most common cause for low flame sense during heat operation is that the flame sense rod may need cleaning or may not be properly connected or wiring between the rod and the furnace control may be shorted or opened.  (2) Another cause for low flame may be an improperly mounted or poorly grounded flame sensor. (3) Flame pattern may be unstable.
	<b>SOLUTION:</b> (1) Clean or replace the flame sense rod or check all connections and wire between the rod and the furnace control (or I.F.C.).  (2) Reinstall or replace flame sensor and check wiring and connections. Also make sure the furnace is properly grounded.  (3) Check that all burner assembly components are properly installed. Check for good seals between the burner and blower compartments. Insure that the combustion door gasket is in place and the door is properly installed and sealed.
<b>14</b>	<b>FLAME PRESENT WITH GAS VALVE OFF</b>
	<b>STATUS:</b> This is an extremely critical fault and should rarely (if ever) be seen in the field. The furnace will not operate with this fault present.
	<b>DESCRIPTION:</b> This fault indicates flame is present when it should not be. Flame is seen to be present when the gas valve is supposed to be off.
	<b>EXPECTED OPERATION:</b> When unexpected flame is sensed, the IBM (Indoor Blower Motor) is energized at maximum heat speed and IDM (Induced Draft Motor) is energized at high speed. Both will remain energized until the fault is cleared. Response to any thermostat call is not permitted until the fault is cleared. Note that the gas valve circuit should not have been energized when the unexpected flame was sensed. When the condition causing the fault is cleared, the IDM will complete a 20 second post-purge and the IBM will complete a 90 second blower off-delay. The control will then enter a one-hour lockout and display the fault codes "10" (one-hour lockout) and "14" (unexpected flame) alternately for the duration of the one-hour lockout. Operation is returned to normal after the lockout period.
	<b>CAUSE:</b> (1) Field mis-wiring of 24VAC to the gas valve main solenoid. (2) Faulty gas valve stuck in the "OPEN" position. (3) Faulty furnace control (signal improperly sensed when it should not be sensed at all).
	<b>SOLUTION:</b> (1) Wire properly. (2) Replace gas valve. (3) Replace furnace control.

**TABLE 19 (continued)**  
**98% MODULATING FURNACE FAULT CODES WITH DESCRIPTIONS AND SOLUTIONS**

22	<b>MAIN LIMIT OPEN</b>
	<b>STATUS:</b> This is a critical fault. The furnace will not operate in gas heat modes but all other modes (e.g. cooling) should function.
	<b>DESCRIPTION:</b> The main limit has opened or is sensed to be opened. This normally means that the temperature inside the heat exchanger area has gone above a certain predetermined critical value and heating operation is not permitted until the limit cools to within normal parameters.
	<b>EXPECTED OPERATION:</b> When the main limit opens, the IBM (Indoor Blower Motor) will be energized at maximum heat speed. The gas valve circuit is de-energized (if it was energized) until the fault is cleared and the IDM (Induced Draft Motor) is energized at high speed and remains energized until the fault has cleared (limit has closed back). Response to thermostat cooling and fan calls will take place as normal. When the fault has cleared, the IBM will remain energized for the 90 second blower off delay period. If the limit control was opened for less than 150 seconds (2m:30sec), operation will proceed as normal after the post purge and blower off delays. However, if the limit is opened for more than 150 seconds, the control will declare a dead (non-functional) blower and proceed to a one-hour lockout and will alternately display fault codes "10" (one-hour lockout) and "61" dead blower at the furnace seven-segment display. Operation will proceed as described under fault code "61".
<b>CAUSE:</b> (1) No airflow (2) Insufficient airflow (3) Faulty limit control (4) Loose or faulty wiring. (5) Dead (non-functional) blower. (6) Input too high	
<b>SOLUTION:</b> (1) Check for proper blower operation. Is the blower turning during heat (or any other) mode? If not, a blower motor fault should also be present. Check the wiring to the motor then check the motor. It may need replacing. (2) Check ductwork and filters. Determine the static pressure and make sure it is not above the published values for the furnace. Check the rate and outlet air temperature at high and low-fire heat (use the test mode dipswitches SW3-13 and SW3-14) and compare to the nameplate maximum values. Also, if the SA sensor is installed cycle power to furnace and allow it to reset. (3) Replace the limit control. (4) Check wiring and connections. Replace and/or repair as necessary. (5) See Fault Code 61 for description, causes, operation and solutions. (6) Insure properly sized burner orifices are installed. Check the manifold pressure at high fire and compare to the nameplate values. Adjust as needed.	
23	<b>HALC OPEN</b>
	<b>STATUS:</b> This is a critical fault. The furnace will not operate in gas heat modes but all other modes (e.g. cooling) should function.
	<b>DESCRIPTION:</b> This fault is displayed when the IFC does not sense continuity between pins 3 and 5 of connector P1 on the furnace control. Note: The fault code exists in the list of fault codes but the furnace as currently configured does not include an HALC control. There is a jumper wire in place of the control and, when the furnace control displays this fault, it generally means that the jumper wire is not making connection between the two pins on the control.
	<b>EXPECTED OPERATION:</b> When the circuit has been opened, the IBM (Indoor Blower Motor) is energized at maximum heating speed. The gas valve circuit is de-energized (if it was energized) and the IDM (Induced Draft Motor) is energized at high speed for 20 seconds after the fault is sensed. Response to thermostat cooling calls will take place as normal with IBM energizing at the higher of the two blower speeds (high heat or cool) when a call for cooling is also present. When the fault is cleared, the IBM will remain energized for the 90 second blower off-delay period.
<b>CAUSE:</b> No continuity between pins 3 and 5 of connector P1 on the furnace control.	
<b>SOLUTION:</b> (1) Repair the jumper between pins 3 and 5 of connector P1 on the furnace control.	
26	<b>LINE AND NEUTRAL REVERSED OR POOR GROUND</b>
	<b>STATUS:</b> This is a critical fault. The furnace will not operate in gas heat or any other modes.
	<b>DESCRIPTION:</b> This fault code is an indication that line voltage and neutral are reversed to the furnace control or may also be an indication of a grounding issue. No operation is not allowed to proceed until the problem is corrected.
	<b>EXPECTED OPERATION:</b> No heating or cooling operation will take place.
<b>CAUSE:</b> (1) Line and neutral to the furnace have been interchanged at the furnace. (2) Line voltage and neutral have been interchanged at the disconnect or at the breaker box. (3) Furnace control cannot properly sense ground.	
<b>SOLUTION:</b> (1) Check voltage with meter and reverse line and neutral if necessary. (2) Check voltage with meter and reverse line and neutral if necessary. (3) Check ground wire inside furnace cabinet is attached to sheet metal, verify ground to furnace cabinet and at breaker box.	

**TABLE 19 (continued)**  
**98% MODULATING FURNACE FAULT CODES WITH DESCRIPTIONS AND SOLUTIONS**

<b>30</b>	<b>OPEN FUSE</b>
	<b>STATUS:</b> This is a critical fault. The furnace will not operate in any mode.
	<b>DESCRIPTION:</b> The fuse has been opened. This usually occurs when there is a 24VAC short to common or ground on the low-voltage side of the transformer.
	<b>EXPECTED OPERATION:</b> The fault code is displayed and no other operation can take place.
	<b>CAUSE:</b> An electrical short from low voltage (24VAC) to ground or common has occurred.
	<b>SOLUTION:</b> Repair the short circuit condition and replace fuse.
<b>OVER-TEMPERATURE SWITCH (ROLL-OUT) OPEN</b>	
<b>33</b>	<b>STATUS:</b> This is a critical fault. The furnace will not operate in gas heat modes but all other modes (e.g. cooling) should function.
	<b>DESCRIPTION:</b> The Manually Reset Limit Control (M.R.L.C.) is also known by the name "Rollout Limit". There can be several on any given furnace. When one or more of these limits open, they must be manually pushed back to the closed position (hence the name; <i>Manually</i> Reset) to force the acknowledgement of a critical fault. This fault will occur when flames have rolled out of the normal area in the heat exchanger and into the burner compartment. This fault should rarely (if ever) be seen in the field and indicates a very serious problem that must be repaired before furnace operation can continue.
	<b>EXPECTED OPERATION:</b> When the MRLC (Manually Reset Limit Control) circuit has been opened, the IBM (Indoor Blower Motor) is energized at maximum heating speed. The gas valve circuit is de-energized (if it was energized) and the IDM (Induced Draft Motor) is energized at high speed. Response to thermostat cooling calls will take place as normal with IBM energizing at the higher of the two blower speeds (high heat or cool) when a call for cooling is also present. When the fault is cleared, the IDM will remain energized for a 20 second post-purge and the IBM will remain energized for the user-selected blower off-delay period.
	<b>CAUSE:</b> (1) Insufficient venting through either the inlet or exhaust. (2) Loose or faulty wiring. (3) Unstable flame pattern.
	<b>SOLUTION:</b> (1) Check that the pressure switch(es) have not been welded closed or bypassed. Check that the inducer is operating at the proper rpm. Insure that the venting does not exceed the maximum specified lengths. Check for obstructions in combustion venting. Check that all gaskets between the inducer and center panel / heat exchanger are properly installed and sealed.  (2) Check wiring and connections. Replace and/or repair as necessary. (3) Check that all burner assembly components are properly installed. Check that all seals between the burner and blower compartments are tight. Insure that the door seals are in place and that the burner door is properly installed and does not leak. Check to make sure that the heat exchanger has not been damaged; i.e.: crushed tubes, breached collector box and etc.
<b>LOW PRESSURE SWITCH CLOSED, INDUCER OFF</b>	
<b>44</b>	<b>STATUS:</b> This is a critical fault. The furnace will not operate in gas heat modes but all other modes (e.g. cooling) should function if present simultaneously with a heating call (e.g. defrost call in dual-fuel mode).
	<b>DESCRIPTION:</b> The low pressure control (or switch) should not be closed when the inducer is not running. If it is, this is a sign of a serious condition. The switch may be welded closed or purposely bypassed in the field. Before any heat cycle can begin, the pressure switch is tested to make sure that it is opened. The switch is ignored except in gas heating modes.
	<b>EXPECTED OPERATION:</b> There will be no other operation than displaying of the fault code and diagnostic messages to the homeowner and technician. The fault code is only present during a heat call <i>before</i> pre-purge begins.
	<b>CAUSE:</b> (1) Faulty switch. (2) Pressure switch physically bypassed in the field. (3) Loose or faulty wiring. (4) Abnormally high negative pressure present on vent system without inducer running.
	<b>SOLUTION:</b> (1) Replace low pressure control (switch). (2) Remove bypass and restore correct operation. Determine reason for bypass (e.g. vent length too long) and correct issue. Notify homeowner and proper authorities of illegal tampering if necessary. (3) Check wiring and connections. Replace and/or repair as necessary. (4) Check for proper venting and terminations as defined in the furnace installation instructions.



**TABLE 19 (continued)**  
**98% MODULATING FURNACE FAULT CODES WITH DESCRIPTIONS AND SOLUTIONS**

<b>LOW PRESSURE SWITCH OPEN, INDUCER ON HIGH SPEED</b>	
<b>45</b>	<p><b>STATUS:</b> This is a critical fault. The furnace will not operate in gas heat modes but all other modes (e.g. cooling) should function if present simultaneously with a heating call (e.g. defrost call in dual-fuel mode).</p> <p><b>DESCRIPTION:</b> This fault indicates that the low pressure switch is open <i>when the inducer is energized at high speed</i>. The switch must close after the inducer is energized and before the ignition sequence can begin. The switch is ignored except in heating modes.</p> <p><b>EXPECTED OPERATION:</b> (1) <b>DISPLAYED BEFORE HEAT IS ESTABLISHED:</b> The IBM (Indoor Blower Motor) will not be energized. The fault code will not be displayed until the IDM (Induced Draft Motor) has been energized for a minimum of ten seconds. The IDM will remain energized at the high speed (high speed is default pre-purge speed) for a period of five minutes after the beginning of the pre-purge attempt. After five minutes, the IDM is de-energized and second attempt at pre-purge is made (as long as the heat call is still present). This cycle is repeated indefinitely until either the pressure switch closes or the heat call is lost. (2) <b>DISPLAYED AFTER HEAT IS ESTABLISHED</b> - If this fault is displayed <i>after</i> heat is established, the gas valve will be de-energized, the IBM will be energized (if not already energized) at the correct heat speed (determined by the firing rate required by the thermostat) and the IDM will remain energized at high speed. The IBM will complete a 90 second blower off-delay and the IDM will complete a 20 second post-purge (at high speed). After these delays, a new attempt at ignition will be made provided the call for heat is still present.</p>
	<p><b>CAUSE:</b></p> <ol style="list-style-type: none"> <li>(1) Blockage or improper termination in either the inlet or exhaust vents.</li> <li>(2) The flue vent length and/or number of elbows exceeds the maximum number specified.</li> <li>(3) Faulty or disconnected inducer.</li> <li>(4) Faulty control board (inducer relay).</li> <li>(5) Loose or faulty wiring.</li> <li>(6) Disconnected, blocked, split or cut pressure switch hoses.</li> <li>(7) Wind gusts (sporadic).</li> <li>(8) Faulty pressure switch.</li> </ol>
	<p><b>SOLUTION:</b></p> <ol style="list-style-type: none"> <li>(1) Check the vent system for blockage and proper termination and repair as necessary.</li> <li>(2) Check the specification sheets and/or installation instructions. Remove excess venting.</li> <li>(3) Repair or replace inducer and/or inducer wiring and/or electrical connections.</li> <li>(4) Replace control board.</li> <li>(5) Check wiring and connections. Replace and/or repair as necessary.</li> <li>(6) Replace hoses as necessary.</li> <li>(7) Insure proper termination and determine if high altitude kit may be necessary (see item 4)</li> <li>(8) Replace the pressure switch.</li> </ol>
<b>LOW PRESSURE SWITCH OPEN, INDUCER ON LOW SPEED</b>	
<b>46</b>	<p><b>STATUS:</b> This is a critical fault. The furnace will not operate in gas heat modes but all other modes (e.g. cooling) should function if present simultaneously with a heating call (e.g. defrost call in dual-fuel mode).</p> <p><b>DESCRIPTION:</b> This fault indicates that the low pressure switch is open <i>when the inducer is energized at low speed</i>. Since the furnace only ignites at high fire, this condition should never be seen except after the blower on delay period of the ignition cycle and only after the furnace attempt to switch to low stage heating. The switch is ignored except in heating modes.</p> <p><b>EXPECTED OPERATION:</b> This fault is displayed only after heat is established and switched to low fire with the IBM (Indoor Blower Motor) energized at low speed. When this fault is displayed the gas valve will be de-energized, the IBM will remain energized at the low heat speed and the IDM (Induced Draft Motor) will remain energized at the low speed. The IBM will complete the user-selected blower off-delay (at low speed) and the IDM will complete a 20 second post-purge (at low speed). After these delays, a new attempt at ignition will be made provided the call for heat is still present.</p>
	<p><b>CAUSE:</b></p> <ol style="list-style-type: none"> <li>(1) Blockage or improper termination in either the inlet or exhaust vents.</li> <li>(2) The flue vent length and/or number of elbows exceeds the maximum number specified.</li> <li>(3) Faulty or disconnected inducer.</li> <li>(4) Faulty control board (inducer relay).</li> <li>(5) High altitude kit not installed in areas of high elevation.</li> <li>(6) Loose or faulty wiring.</li> <li>(7) Disconnected, blocked, split or cut pressure switch hoses.</li> <li>(8) Wind gusts (sporadic).</li> <li>(9) Faulty pressure switch.</li> </ol>
	<p><b>SOLUTION:</b></p> <ol style="list-style-type: none"> <li>(1) Check the vent system for blockage and proper termination and repair as necessary.</li> <li>(2) Check the specification sheets and/or installation instructions. Remove excess venting.</li> <li>(3) Repair or replace inducer and/or inducer wiring and/or electrical connections.</li> <li>(4) Replace control board.</li> <li>(5) Check elevation of the installation and consult the specifications for the furnace to determine if a high altitude kit is needed. Install proper kit as necessary.</li> <li>(6) Check wiring and connections. Replace and/or repair as necessary.</li> <li>(7) Replace hoses as necessary.</li> <li>(8) Insure proper termination and determine if high altitude kit may be necessary (see item 4)</li> <li>(9) Replace the pressure switch.</li> </ol>

**TABLE 19 (continued)**  
**98% MODULATING FURNACE FAULT CODES WITH DESCRIPTIONS AND SOLUTIONS**

<b>55</b>	<b>HIGH PRESSURE SWITCH CLOSED, INDUCER OFF</b>
	<p><b>STATUS:</b> This is a critical fault. The furnace will not operate in gas heat modes but all other modes (e.g. cooling) should function if present simultaneously with a heating call (e.g. defrost call in dual-fuel mode).</p> <p><b>DESCRIPTION:</b> The high pressure control (or switch) should not be closed when the inducer is not running. If it is, this is a sign of a serious condition. The switch may be welded closed or purposely bypassed in the field. Before any heat cycle can begin, the pressure switch is tested to make sure that it is opened. The switch is ignored except in gas heating modes.</p>
	<p><b>EXPECTED OPERATION:</b> There will be no other operation than displaying of the fault code and diagnostic messages to the homeowner and technician. The fault code is only present during a heat call before pre-purge begins.</p>
	<p><b>CAUSE:</b></p> <ol style="list-style-type: none"> <li>(1) Faulty switch.</li> <li>(2) Pressure switch physically bypassed in the field.</li> <li>(3) Loose or faulty wiring.</li> <li>(4) Abnormally high negative pressure present on vent system without inducer running.</li> </ol> <p><b>SOLUTION:</b></p> <ol style="list-style-type: none"> <li>(1) Replace high pressure control (switch).</li> <li>(2) Remove bypass and restore correct operation. Determine reason for bypass (e.g. vent length too long) and correct issue. Notify homeowner and proper authorities of illegal tampering if necessary.</li> <li>(3) Check wiring and connections. Replace and/or repair as necessary.</li> <li>(4) Check for proper venting and terminations as defined in the furnace installation instructions.</li> </ol>
<b>57</b>	<b>HIGH PRESSURE SWITCH OPEN, INDUCER ON HIGH SPEED</b>
	<p><b>STATUS:</b> This is a critical fault. The furnace will not operate in gas heat modes but all other modes (e.g. cooling) should function if present simultaneously with a heating call (e.g. defrost call in dual-fuel mode). If this fault is experienced during high heat operation and the low pressure switch remains engaged, the furnace will switch to low fire heat and continue to run (if possible) to try to satisfy the thermostat.</p> <p><b>DESCRIPTION:</b> This fault indicates that the high pressure switch is open when the inducer is energized at high speed. This fault can be displayed any time during the heat call except during low heat call and only <i>after</i> the pre-purge and blower on delays are complete.</p>
	<p><b>EXPECTED OPERATION:</b> (1) <b>DISPLAYED BEFORE HEAT IS ESTABLISHED:</b> The IBM (Indoor Blower Motor) will not be energized. The fault code will not be displayed until the IDM (Induced Draft Motor) has been energized for a minimum of ten seconds. The IDM will remain energized at the high speed (high speed is default pre-purge speed) for a period of five minutes after the beginning of the pre-purge attempt. After five minutes, the IDM is de-energized and second attempt at pre-purge is made (as long as the heat call is still present). This cycle is repeated indefinitely until either the pressure switch closes or the heat call is lost. (2) <b>DISPLAYED AFTER HEAT IS ESTABLISHED</b> - If this fault is displayed after heat is established, the IDM will remain energized at high speed and the firing rate will drop to low stage provided the low pressure switch remains closed. The IBM will energize at, or switch to, the low-fire rate (also provided the low pressure switch remains closed). Low heat is provided until the heat call ends or the high pressure switch closes. If the high pressure switch closes, the heat rate and blower speed will be adjusted to the correct (higher) rate required by the thermostat and the IDM will remain energized at high speed. If the low pressure switch also will not remain closed, operation will be as described under fault code # 46 ("LPC OPEN") above.</p>
	<p><b>CAUSE:</b></p> <ol style="list-style-type: none"> <li>(1) Blockage or improper termination in either the inlet or exhaust vents.</li> <li>(2) The flue vent length and/or number of elbows exceeds the maximum number specified.</li> <li>(3) Faulty or disconnected inducer.</li> <li>(4) Faulty control board (inducer relay).</li> <li>(5) High altitude kit not installed in areas of high elevation.</li> <li>(6) Loose or faulty wiring.</li> <li>(7) Disconnected, blocked, split or cut pressure switch hoses.</li> <li>(8) Wind gusts (sporadic).</li> <li>(9) Faulty pressure switch.</li> </ol> <p><b>SOLUTION:</b></p> <ol style="list-style-type: none"> <li>(1) Check the vent system for blockage and proper termination and repair as necessary.</li> <li>(2) Check the specification sheets and/or installation instructions. Remove excess venting.</li> <li>(3) Repair or replace inducer and/or inducer wiring and/or electrical connections.</li> <li>(4) Replace control board.</li> <li>(5) Check elevation of the installation and consult the specifications for the furnace to determine if a high altitude kit is needed. Install proper kit as necessary.</li> <li>(6) Check wiring and connections. Replace and/or repair as necessary.</li> <li>(7) Replace hoses as necessary.</li> <li>(8) Insure proper termination and determine if high altitude kit may be necessary (see item 4)</li> <li>(9) Replace the pressure switch.</li> </ol>
<b>58</b>	<b>WATER CIRCUIT OPEN</b>
	<p><b>STATUS:</b> This is a critical fault experienced by the furnace. The furnace will not operate in gas heat modes but all other modes (e.g. cooling) should function if a call is present.</p> <p><b>DESCRIPTION:</b> The IFC cannot detect electrical continuity between pins 1 and 2 of connector P4 of the furnace control. The IFC looks for continuity between these pins to determine if the water sensors (2) are present in the circuit. When both sensors are present and properly connected and wiring is not damaged, there should be electrical continuity between these pins.</p>
	<p><b>EXPECTED OPERATION:</b> No gas heating operation can proceed and the fault is displayed. All other modes (e.g. cooling) of operation should operate as normal.</p>
	<p><b>CAUSE:</b></p> <ol style="list-style-type: none"> <li>(1) Wiring has been damaged between the control or sensor.</li> <li>(2) Connection of P4 at the IFC or at the water sensors is not properly made.</li> <li>(3) Water sensor has been removed.</li> </ol> <p><b>SOLUTION:</b></p> <ol style="list-style-type: none"> <li>(1) Repair or replace wiring.</li> <li>(2) Repair connections or replace wiring or sensors or controls as necessary.</li> <li>(3) Replace missing water sensor.</li> </ol>

**TABLE 19 (continued)**  
**98% MODULATING FURNACE FAULT CODES WITH DESCRIPTIONS AND SOLUTIONS**

<b>WATER SENSED</b>	
<b>59</b>	<b>STATUS:</b> This is a critical fault experienced by the furnace. The furnace will not operate in gas heat modes but all other modes (e.g. cooling) should function if a call is present.
	<b>DESCRIPTION:</b> The IFC has detected current flowing from pin(s) 1 and/or 2 of connector P4 of the furnace control. The IFC looks for current flow from these pins to determine if water is present in the collector box. When water is present, the sensor will pass a small amount of electrical current to the sheet metal of the furnace. This current flow will notify the IFC that water is present. Note: The condition must be present continuously for at least ten seconds before the IFC will declare the fault.
	<b>EXPECTED OPERATION:</b> No gas heating operation can proceed and the fault is displayed. All other modes (e.g. cooling) of operation should operate as normal.
	<b>CAUSE:</b> (1) A blocked condensate drain or the drain trap has become blocked and cannot allow condensate water to flow properly. (2) Wiring to the sensors has been damaged and exposed wiring is touching the furnace sheet metal. (3) Water sensor has been removed from the collector box with wires still attached and the metal probe is touching the sheet metal portion of the furnace.
	<b>SOLUTION:</b> (1) Remove/Repair drain blockage. (2) Replace/Repair wiring between IFC and both sensors. (3) Return sensor(s) to proper location in the collector box.
<b>BLOWER FAULT - BLOWER CAN STILL RUN</b>	
<b>60</b>	<b>STATUS:</b> This is a non-critical fault experienced by the furnace. All operations (including thermostat calls) should continue as normal with no perceivable difference in operation.
	<b>DESCRIPTION:</b> A blower fault which is non-critical allows the blower to continue to run but at less-than-optimal conditions.
	<b>EXPECTED OPERATION:</b> All (including thermostat) operation should continue as normal. Blower operation may be slightly compromised but will continue.
	<b>CAUSE:</b> (1) The blower has hit the maximum speed or torque limit specified by the manufacturer or is running at the temperature limit because the static pressure is too high.
	<b>SOLUTION:</b> (1) The static pressure is too high because the ductwork is improperly designed or is restricted for some other reason or the filter needs cleaning or replacing. Remove the obstruction or repair the duct so that static pressure does not exceed published values in the specification sheets or installation instructions.
<b>BLOWER FAULT - MOTOR CANNOT RUN</b>	
<b>61</b>	<b>STATUS:</b> This is a critical fault. The furnace will not operate in any mode.
	<b>DESCRIPTION:</b> The blower has failed critically or there is a critical motor fault - such as thermal limit trip that prevents the blower motor from running.
	<b>EXPECTED OPERATION:</b> If the furnace was in heating operation when this fault occurred, blower operation will immediately stop and the furnace will shut down normally with post-purge at the correct speed. After the post purge (or immediately if no heat call was present), no other operation (including thermostat calls) will occur until this fault is cleared. This fault may be displayed in heating or cooling modes and may also be displayed in heating mode after the main limit control has been opened four times consecutively for more than 150 seconds (2m:30sec) each time. If this happens, the IFC determines that the motor and/or blower is not functional and enters a hard lockout condition requiring repair of the blower/motor and manual reset of power to the furnace.
	<b>CAUSE:</b> (1) The motor has tripped on thermal limit because of a restriction or bearing failure. (2) The motor Power Factor Correction (P.F.C.) choke is faulty and needs replacing. (3) The furnace model data is faulty or corrupted. (4) Wiring to the motor and/or P.F.C. has become compromised. (5) The blower wheel has become damaged or is not properly attached to the motor shaft. (6) The motor has failed catastrophically.
	<b>SOLUTION:</b> (1) Remove obstruction or replace motor. (2) Replace the Power Factor Correction choke. (3) Replace the furnace memory card with the correct replacement part from ProStock. (4) Inspect and replace or repair wiring and/or connectors to the motor and/or P.F.C. as necessary. (5) Replace the blower wheel and/or attach the blower wheel to the motor shaft properly. (6) Replace the motor.

**TABLE 19 (continued)**  
**98% MODULATING FURNACE FAULT CODES WITH DESCRIPTIONS AND SOLUTIONS**

<b>65</b>	<b>MID PRESSURE SWITCH CLOSED, SHOULD BE OPEN</b>
	<b>Status:</b> This is a non-critical fault. The furnace will operate in gas heat modes but gas heat firing rate demands from the thermostat between 50% and 65% will operate at 70% instead.
	<b>Description:</b> This fault indicates that the mid pressure switch is electrically closed when it should be open.
	<b>Expected operation:</b> Gas heating will proceed as normal except firing rates between 50% and 65% will be fixed to 70% by the furnace control.
	<b>Cause:</b> (1) Bad wiring to mid pressure switch. (2) Bad mid pressure switch. (3) Bad furnace control.
	<b>Solution:</b> (1) Check wiring and connections between mid pressure switch and furnace control. Correct/replace as necessary. (2) Replace mid pressure switch. (3) Replace Furnace control.
<b>66</b>	<b>BLOWER CUTBACK</b>
	<b>STATUS:</b> This is a non-critical fault experienced by the furnace. All operations (including thermostat calls) should continue as normal with no perceivable difference in operation.
	<b>DESCRIPTION:</b> The blower motor is operating at the highest rpm or torque that specifications allow but the application requires more torque or speed in order to get the desired airflow under the current static pressure conditions. The motor will continue to operate because internal software will prevent operation above the permitted range. However, a fault is sent to the furnace control (or I.F.C.) from the motor. <div style="text-align: right;"><b>Note:</b> This fault will not be displayed after the first three minutes of blower operation after power reset. Further, this fault will not be logged in the fault buffer or fault history after the first hour of operation and will only be logged into the fault buffer a maximum of one time.</div>
	<b>EXPECTED OPERATION:</b> All (including thermostat) operation should continue as normal. Blower operation may be slightly compromised but will continue.
	<b>CAUSE:</b> (1) The blower has hit the maximum speed or torque limit specified by the manufacturer because the static pressure is too high.
	<b>SOLUTION:</b> (1) The static pressure is too high because the ductwork is improperly designed or is restricted for some other reason or the filter needs cleaning or replacing. Remove the obstruction or repair the duct so that static pressure does not exceed published values in the specification sheets or installation instructions for the furnace.
<b>67</b>	<b>MID PRESSURE SWITCH OPEN, SHOULD BE CLOSED</b>
	<b>Status:</b> This is a non-critical fault. The furnace will operate in gas heat modes but gas heat firing rate demands from the thermostat between 50% and 65% will operate at 70% instead.
	<b>Description:</b> This fault indicates that the mid pressure switch is electrically open when it should be closed.
	<b>Expected operation:</b> Gas heating will proceed as normal except firing rates between 50% and 65% will be fixed to 70% by the furnace control.
	<b>Cause:</b> (1) Wind gusts. (2) Improper venting. (3) Bad wiring to mid pressure switch. (4) Bad mid pressure switch. (5) Bad furnace control.
	<b>Solution:</b> (1) Check venting is per this instruction book. Correct if not right. Wait for wind condition to clear. (2) Correct venting and make sure lengths and construction comply with this instruction book. (3) Check wiring and connections between mid pressure switch and furnace control. Correct/replace as necessary. (4) Replace mid pressure switch. (5) Replace Furnace control.

**TABLE 19 (continued)**  
**98% MODULATING FURNACE FAULT CODES WITH DESCRIPTIONS AND SOLUTIONS**

68	<b>NO BLOWER COMMUNICATIONS</b>
	<b>STATUS:</b> This is a critical fault. The furnace will not operate in any mode.
	<b>DESCRIPTION:</b> The furnace control (I.F.C.) can not communicate with the blower motor.
	<b>EXPECTED OPERATION:</b> If the furnace was in heating operation when this fault occurred, the gas valve will immediately close (flame will be lost), IBM (Indoor Blower Motor) operation will immediately stop and the furnace will shut down normally (except without IBM operation) with IDM (Induced Draft Motor) post-purge at the correct speed. After the post purge (or immediately if no heat call was present), no other operation (including thermostat calls) will occur until this fault is cleared.
	<b>CAUSE:</b> (1) The wires between the blower motor have been disconnected or there is a poor connection. (2) There is no line voltage to the motor. (3) The furnace model data is faulty or corrupted. (4) The motor has failed catastrophically.
71	<b>INDUCER FAULT</b>
	<b>Status:</b> This is a critical fault. The furnace will not operate in gas heat modes but all other modes (e.g. cooling) should function if present simultaneously with a heating call (e.g. defrost call in dual-fuel mode).
	<b>Description:</b> This fault indicates that the inducer is not working properly. Note: This fault may be seen under normal operating conditions if power is lost and returned quickly (within 30 seconds) while operating in gas heating mode.
	<b>Expected operation:</b> The fault is displayed when too much or too little current is detected on the inducer circuit.
	<b>Cause:</b> (1) Power outage. (2) Bad wiring to inducer. (3) Bad inducer. (4) Bad furnace control.
77	<b>NO GAS VALVE FEEDBACK SIGNAL</b>
	<b>Status:</b> This is a critical fault. The furnace will not operate in gas heat modes but all other modes (e.g. cooling) should function if present simultaneously with a heating call (e.g. defrost call in dual-fuel mode).
	<b>Description:</b> This fault indicates that the gas valve is not working properly and has lost communications with the furnace control board.
	<b>Expected operation:</b> The fault is displayed when furnace control cannot communicate with the gas valve.
	<b>Cause:</b> (1) Bad wiring to gas valve. (2) Bad gas valve. (3) Bad furnace control.
93	<b>INTERNAL CONTROL FAULT DETECTED</b>
	<b>STATUS:</b> This is a critical fault. The furnace will not operate in any mode of operation.
	<b>DESCRIPTION:</b> This is a severe fault that should rarely (if ever) be discovered in the field. It is an indicator of an internal microprocessor fault on the furnace control (or I.F.C.) or voltage applied to the main gas valve solenoid when there should be none.
	<b>EXPECTED OPERATION:</b> If possible, if the furnace was in heating operation when this fault occurred, the gas valve will immediately close (flame will be lost), IBM (Indoor Blower Motor) operation will immediately stop and the furnace will shut down normally (except without IBM operation) with IDM (Induced Draft Motor) post-purge at the correct speed. After the post purge (or immediately if no heat call was present), no other operation (including thermostat calls) will occur until this fault is cleared. However, this fault may also indicate an internal microprocessor failure. This may mean that the heat call will not end as expected and that all outputs will be de-energized and gas valve closed immediately when the fault is sensed.
	<b>CAUSE:</b> (1) 24VAC or similar voltage applied to the main gas valve solenoid circuit unexpectedly. (2) Furnace control software test failure - failed furnace control (or I.F.C.).
99	<b>REMOTE FAULTS RESET PERFORMED</b>
	This is a notification that fault codes in the fault buffer have been reset.

# DIAGNOSTICS AND TROUBLESHOOTING

## LOCKOUT AND REPLACING THE FURNACE CONTROL

All lockout conditions can be cleared immediately provided that the original fault causing the lockout is cleared and power to the unit is cycled off and then back on again or (soft lockout only) if a heat call is cycled off for greater than 2 seconds but less than 20 seconds.

The furnace control will not initiate a heat cycle during any lockout condition. A call for compressor or continuous fan will generally be responded to but control will display the lockout error fault code instead of the “C” (for compressor) or “F” (for Continuous fan).

### FIVE-MINUTE LOCKOUT

A five minute “soft” lockout will be initiated if the low pressure switch fails to close after 60 seconds of continuous inducer operation at the beginning of a normal heat cycle (pressure switch proving period). The seven-segment display will display the appropriate fault. Lockout will automatically be reset after five minutes.

### ONE-HOUR LOCKOUT

A one hour “soft” lock out will be initiated when:

- Flame has not been detected after four ignition trials.
- Flame has been lost for five times in one heat call.
- Undesired flame has been detected. The one-hour period will commence after flame is no longer detected.
- Dead Blower has been detected (main limit circuit open for more than 150 seconds)
- When voltage has unexpectedly been detected on the gas valve circuit and voltage goes away when inducer is shut off.
- If a *Water Sensed* condition is detected once during heat call (heat cycle terminated in response to fault) and then clears and then is detected again within 5 minutes of the next heat attempt (same heat call).

The seven-segment display will alternately display “10” and the code number for the fault causing the lockout. Lockout will automatically be reset after one hour.

### HARD LOCKOUT

Four conditions shall cause a hard lockout:

1. The control senses an unspecified internal fault. Fault code “93” is set and displayed. This lockout condition cannot be reset by cycling the heat call.
2. Voltage is detected unexpectedly on the gas valve contacts (welded relay) and will not clear by cycling the inducer. Fault code “93” is set and displayed. This lockout condition cannot be reset by cycling the heat call.

3. The furnace control will declare that the blower motor is inoperable (dead) if the main limit control has been open for more than 150 seconds. Gas heating is terminated. However, the control continues to try to operate heating for up to four attempts in case the blower motor starts working again. If a dead blower has been declared four times in one heat call, the furnace control enters a hard-lockout. Fault code “61” is set and displayed. This lockout condition **CAN** be reset by cycling the heat call.
4. The Main Limit Control has opened any time during low heating (40%) operation only.

## REPLACING THE FURNACE CONTROL

In the event that the furnace control must be replaced, the memory card must be removed from the original furnace control and retained with the furnace. A plastic tether with a note wrapped around the tether is used to remind the technician not to remove the card from the furnace. Use this card to insert into the memory card connector labeled P6 of the replacement control board. Failure to save and connect the memory card properly to the replacement control may result in no operation or undesired operation of the furnace.

When replacing the furnace control, be sure to match the dipswitch settings of the original control on the replacement.

**DO NOT CUT THE PLASTIC WIRE TIE USED AS A TETHER TO THE ATTACHED MEMORY CARD. DOING SO WILL DEFEAT THE PURPOSE OF RETAINING THE MEMORY CARD – WHICH COULD LEAD TO A LOSS OF CRITICAL DATA NECESSARY TO OPERATE THE FURNACE. THE CARD MUST STAY WITH THE FURNACE – EVEN WHEN THE FURNACE CONTROL (IFC) MUST BE REPLACED. NEVER USE A CONTROL BOARD TAKEN FROM ANOTHER FURNACE AS A REPLACEMENT CONTROL FOR THIS FURNACE. FURNACE CONTROLS TAKEN FROM OTHER FURNACES MAY CONTAMINATE THE SYSTEM WITH THE WRONG MODEL DATA WHICH CAN ONLY BE FIXED BY REPLACING THE MEMORY CARD WITH THE ORIGINAL MEMORY CARD FROM THE ORIGINAL FURNACE OR A REPLACEMENT MEMORY CARD DESIGNED FOR THE ORIGINAL FURNACE.**

## DIAGNOSING BLOWER MOTOR ISSUES

If the main circulating blower motor will not operate when it should, there are some different methods for diagnosing the problem.

# DIAGNOSTICS AND TROUBLESHOOTING

## DIAGNOSING BLOWER MOTOR ISSUES

### 1. MOTOR POWER AND COMMUNICATIONS ISSUES (FAULT CODE “68”)

Is the motor communicating properly with the furnace control? If not, the fault code “68” will be displayed any time there is a call for cooling, heating or continuous fan. To determine the cause of this issue, follow these steps:

- A. Remove the line voltage connector from the motor. This is the 5-pin connector. With the door switch closed, verify that there is 115-120VAC between pins 4 and 5 of the connector (see photos in Figure 63B). If no line voltage is detected, check the wiring and correct the issue. Line voltage should be present at these pins any time the furnace is powered. Make sure that the pins of the connector are fully seated in the housing to ensure good contact with the connection at the motor. When voltage is confirmed at these pins, replace the connector on the motor.
- B. Remove the motor control connector from the furnace control at P5 and apply 24VAC to pins 3 & 4 (see photo). With the door switch closed (motor powered) and 24VAC on pins 3 & 4, the motor should start operating at 75% of capacity. If the motor is operating at a good speed, it is likely not the motor that is the problem. If the motor is not operating, verify that the control wiring between the motor and furnace control (to P5) is good and that all the pins on both ends are fully seated. If the wiring connections looks good, and the motor still will not operate, the motor likely needs to be replaced.

**FIGURE 65**  
LINE VOLTAGE AND LOW VOLTAGE CONNECTIONS TO THE COMMUNICATING MOTOR

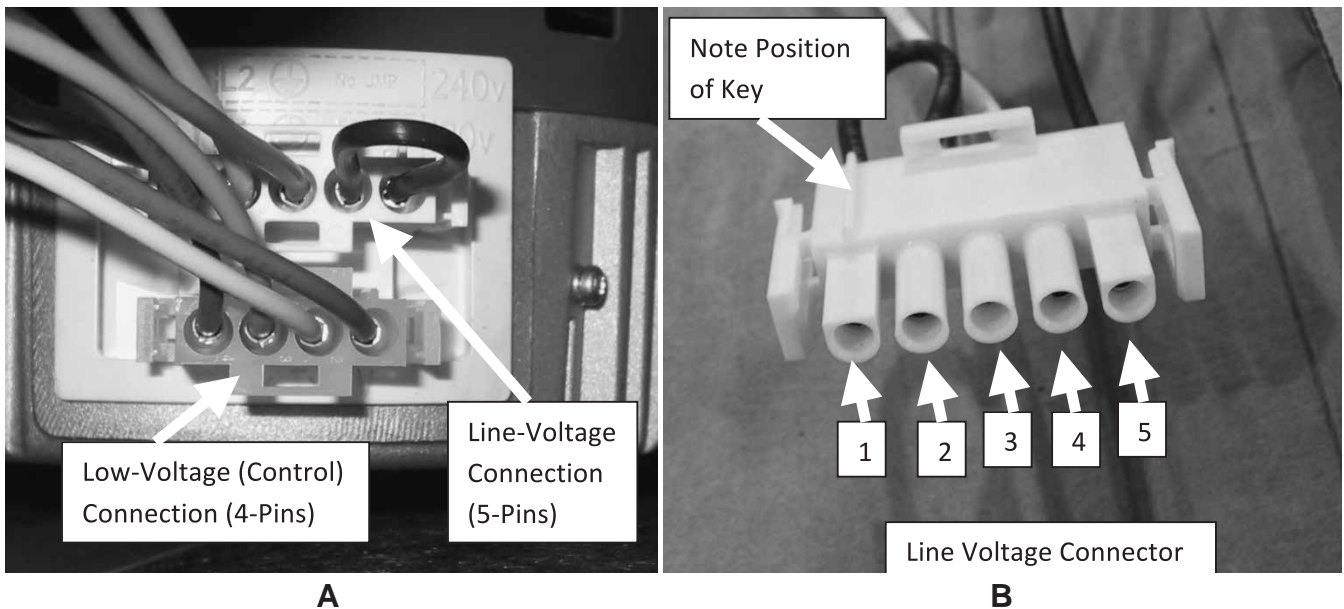

# DIAGNOSTICS AND TROUBLESHOOTING

## DIAGNOSING BLOWER MOTOR ISSUES

**FIGURE 66**  
LOW VOLTAGE CONNECTION PIN DETAIL

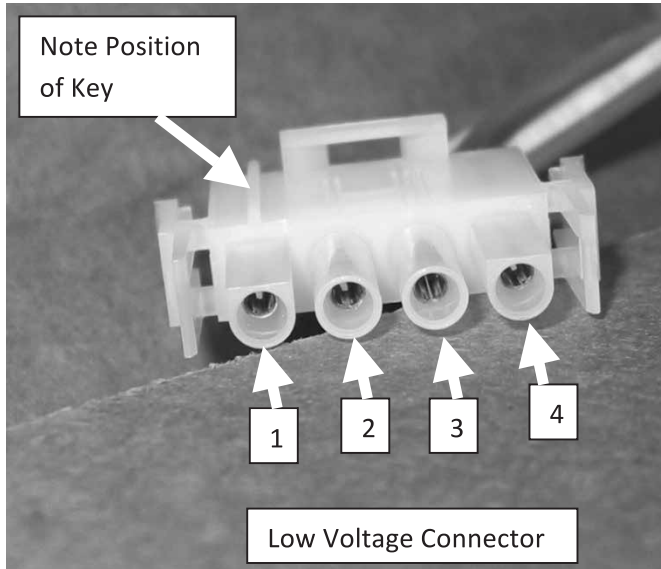

### 2. OVERSPEED OPERATION (CODE “66”)

Note: This code will only be displayed during the first three minutes of blower operation and then only if the call for fan is great enough to force the motor into speed limit.

- A. Is the duct work of the system restrictive or confined? Or, maybe many (or all) of the supply registers are closed in the duct system. If so, the motor may indicate that it is operating in power limit under certain conditions by displaying code “66”. Remove the restrictions or reconfigure the duct work to avoid this code.

- B. Is the motor set-screw not tightened to the motor shaft? This may cause erratic motor operation and cause the furnace to display a “66” fault code. Further, airflow will be low or air may not be moving at all.

### 3. INTERNAL ERROR – MOTOR UNABLE TO OPERATE (FAULT CODE “61”)

If the blower motor is able to communicate with the furnace control but is experiencing an internal issue – such as overheating, the fault code “61” will be displayed. Internal overloading may reset once the condition causing the problem has been removed. However, it is likely that the motor will need to be replaced.

- A. Is the motor wheel blocked by an obstruction? If so, the motor may be in locked-rotor state and the furnace control will report fault code “61”. Remove the obstruction and try to operate the motor again. If the motor continues to fail, it may be permanently damaged and may need to be replaced.
- B. Is the motor overheating? If so, it may report an overheat condition to the furnace control and the control will report fault code “61”. Determine the cause of overheating and repair. Try to operate the motor again. If the motor continues to fail, it may be permanently damaged and may need to be replaced.

### 4. INTERNAL ERROR – MOTOR ABLE TO OPERATE (FAULT CODE “60”)

This is a low-level fault that is not likely to be displayed often. Operation will continue as normal but fault code will be displayed. Long-term permanent damage to the motor is not expected.



**FIGURE 67**  
**MODULATING ECM FURNACE WIRING DIAGRAM**

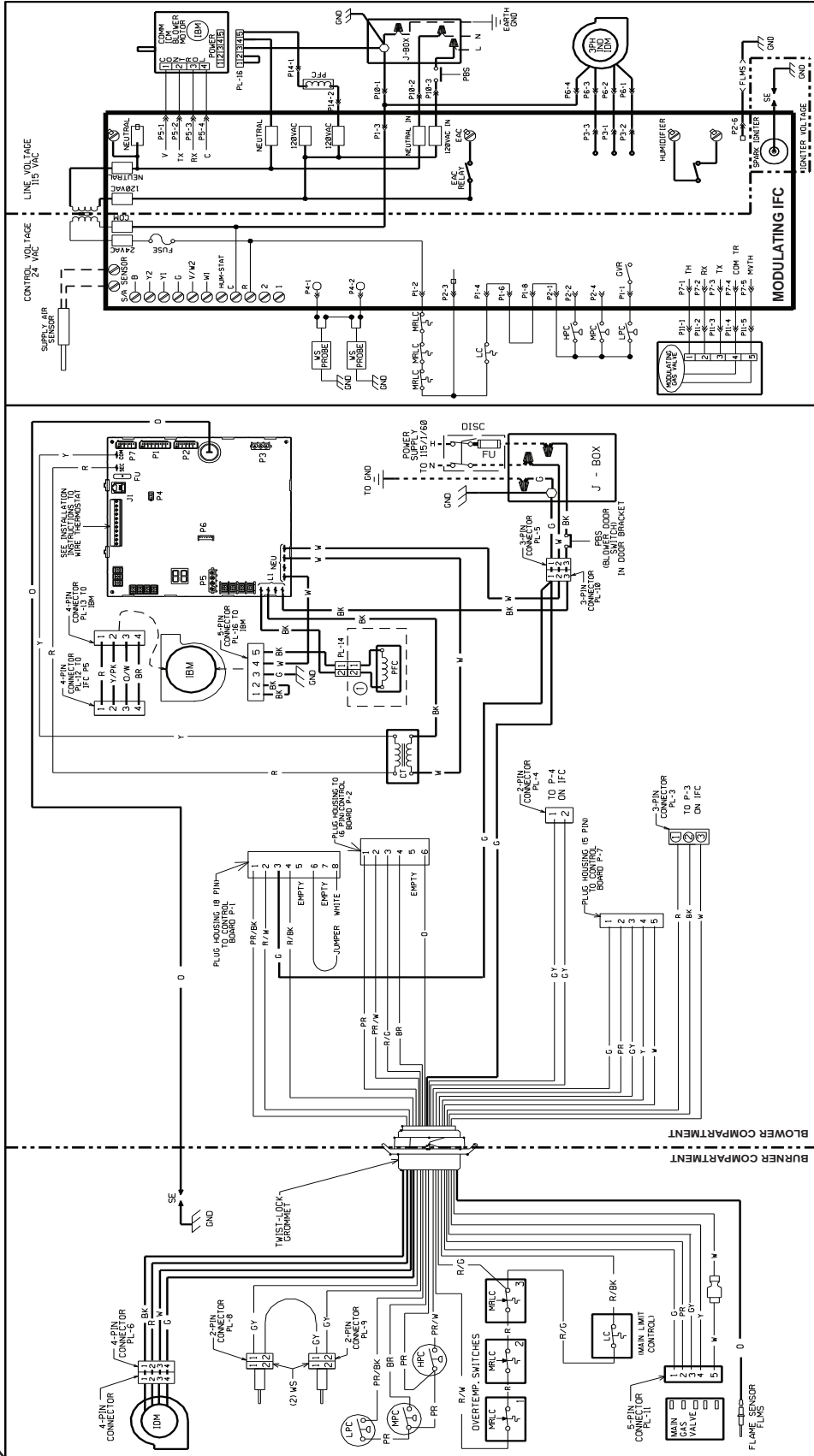

**WIRE COLOR CODE**

BK.....BLACK	G.....GREEN	PK.....PINK
BR.....BROWN	GY.....GRAY	R.....RED
BL.....BLUE	O.....ORANGE	W.....WHITE
	PR.....PURPLE	Y.....YELLOW

**ELECTRICAL WIRING DIAGRAM**

UPFLOW  
 DOWNFLOW/HORIZONTAL  
 3 PH INDUCED DRAFT BLOWER  
 MODULATING 90PLUS ECM  
 GAS FIRED, FORCED AIR FURNACE

APPROVED: \_\_\_\_\_ CHECKED: \_\_\_\_\_ ORIGINAL RELEASE NO.: \_\_\_\_\_  
 MODELED BY: JIM DATE: 8-14-15 NO.: G-10245005  
 PART NO.: 90-105564-01 REV: 05

**COMPONENT CODES**

BLWR	BLOWER RELAY	LPC	LIMIT CONTROL
C	COMMON	MC	MEMORY CARD
CT	CONTROL TRANSFORMER	MGV	MAIN GAS VALVE
DISC	DISCONNECT SWITCH	MPC	MEDIUM PRESSURE CONTROL
EAC	ELECT. AIR CLEANER	MRLC	MAN. RESET LIMIT CONTROL
FLM	FLAME SENSOR	NEU	NEUTRAL
FU	FUSE	PBS	PUSH BUTTON SWITCH
GND	GROUND	PFC	POWER FACTOR CHOKE
HVC	HIGH PRESSURE CONTROL	PLUG	PLUG
HUM	HUMIDIFIER OUTPUT	SE	SPARK ELECTRODE
IDM	INDUCED DRAFT MOTOR	TM	THERMISTOR
IFC	INTEGRATED FURNACE CONTROL	W/S	WATER SENSOR
		WIRENUT	WIRENUT

**NOTES**

1 JUMPER USED IN PLACE OF PRC ON 1/2 HP MOTOR MODELS.

CHASSIS GROUND  
 EARTH GROUND

TWIST-LOCK GROMMET

THE DOTTED BOX NEAR THE DRAWING TITLE REPRESENTS A .25 X .25 2D DATA MATRIX. SEE ADS 104669-01 FOR DATA MATRIX SPECS.

**WIRING INFORMATION**

LINE VOLTAGE  
 -FACTORY STANDARD  
 -FACTORY OPTION  
 -FIELD INSTALLED

LOW VOLTAGE  
 -FACTORY STANDARD  
 -FACTORY OPTION  
 -FIELD INSTALLED

REPLACEMENT WIRE  
 -MUST BE THE SAME SIZE AND TYPE OF INSULATION AS ORIGINAL (105C, MIN)

WARNING  
 -MUST BE PERMANENTLY GROUNDED  
 -GAS VALVE (E.C.V.)  
 -NATIONAL WIRING REGULATIONS, AND LOCAL CODES AS APPLICABLE.





