

External filter racks are available from the distributor. Use the following part numbers when ordering:

RXGF-CA	External Side Filter Rack Kit		
RXGF-CC	External Filter Rack Kit - Downflow		
RXGF-F17	17.5"	15.0"	16.0" X 25.0"
RXGF-F21	21.0"	18.5"	20.0" X 25.0"
RXGF-F24	24.5"	22.0"	20.0" X 25.0"

Proper air flow is required for the correct operation of this furnace. Restricted air flow can cause erratic operation and can damage the heat exchanger. The duct system must carry the correct amount of air for heating and cooling if summer air conditioning is used.

⚠ WARNING

ZONING SYSTEMS ARE NOT DIRECTLY SUPPORTED IN THIS MANUAL. IF A THIRD PARTY SYSTEM IS USED REFER TO THE MANUFACTURER OF THAT PRODUCT FOR INSTALLATION AND OPERATION INSTRUCTIONS.

ZONING SYSTEMS USED ON THIS PRODUCT MUST HAVE SENSORS TO PREVENT FURNACES AND/OR HEATING ELEMENTS FROM CYCLING ON INTERNAL LIMIT CONTROLS. THE ZONING SYSTEM MUST NOT ALLOW THE EVAPORATOR COILS AND/OR HYDRONIC COILS TO FREEZE.

⚠ WARNING

SOME HEATING AIRFLOW VALUES MAY BE HIGHER THAN THOSE REQUIRED FOR COOLING. BE SURE TO SIZE DUCT FOR THE MAXIMUM POSSIBLE AIRFLOW VALUE.

SIZE AIRFLOW DISTRIBUTION SYSTEM TO ACCEPTABLE INDUSTRY STANDARDS AND METHODS. TOTAL STATIC PRESSURE DROP OF THE AIR DISTRIBUTION SYSTEM SHOULD NOT EXCEED 1.0 INCH W.C. THIS WILL INCLUDE ANY AIR CONDITIONER COIL, AIR FILTRATION SYSTEM, ZONING SYSTEM, DUCTWORK, ETC. REFER TO ADDED EQUIPMENT TECHNICAL INFORMATION TO OBTAIN PRESSURE DROP INFORMATION WHEN EQUIPMENT IS OPERATING AT RECOMMENDED HEATING OR COOLING CFMS.

IMPORTANT: When using outside air, design and adjust the system to maintain a return air temperature ABOVE 55° F during the heating season.

NOTE: Return air grilles and warm air registers must not be obstructed or closed.

NOTE: Both flanges on the supply and return openings must be bent either up or down but cannot remain flat as shipped from the factory. See Figure 10 for details.

UPFLOW INSTALLATIONS

1. Position the unit to minimize long runs of duct or runs of duct with many turns and elbows.
2. For side return: Cut an opening in the side. The opening should be cut the full width and height of the knockouts on the unit. See Figure 11.
3. If summer air conditioning is desired, position the indoor coil on the supply-air side of the unit. Ensure that no air can bypass the coil.

FIGURE 8
REMOVE SOLID BASE PANEL FROM THE TOP BEFORE INSTALLING FURNACE

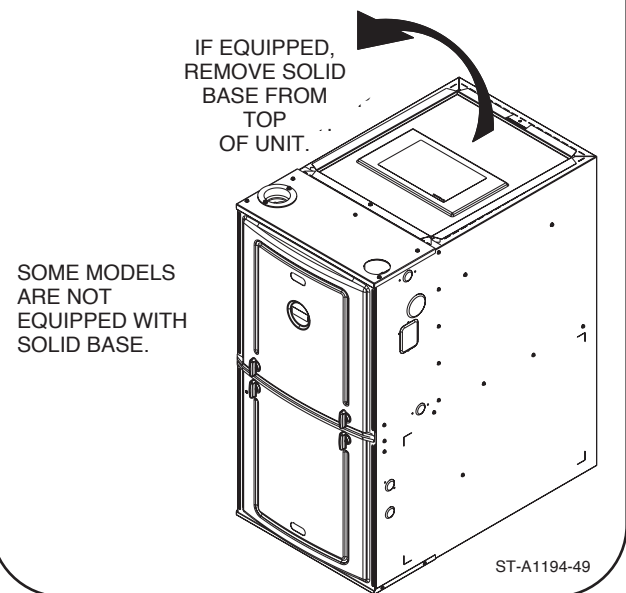

⚠ WARNING

IF EQUIPPED, THE SOLID METAL BASE PAN MUST BE REMOVED FROM THE TOP OF THE FURNACE BEFORE INSTALLING THE FURNACE. FAILURE TO REMOVE THIS PAN FROM THE SHIPPING POSITION CAN RESULT TO DAMAGE TO THE FURNACE OR EQUIPMENT.

⚠ WARNING

BLOWER AND BURNERS MUST NEVER BE OPERATED WITHOUT THE BLOWER DOOR IN PLACE. THIS IS TO PREVENT DRAWING GAS FUMES (WHICH COULD CONTAIN HAZARDOUS CARBON MONOXIDE) INTO THE HOME THAT COULD RESULT IN PERSONAL INJURY OR DEATH.

4. Connect the furnace to the supply air plenum.
5. Connect the return air ducting to the return-air opening at the bottom and/or side of the unit. Make the connections air-tight to prevent the migration of toxic fumes and odors including carbon monoxide from migrating into the living space.
6. If a filter is installed near the furnace, be sure to have adequate space for installation and removal of the unit filter.
7. **NOTE:** Where the maximum airflow is 1800 CFM or more, and multiple return air plenums are required for installation; the bottom and/or **BOTH** sides may be used for the return air, however the rear of the furnace can **NOT** be used as a return air in any configuration.
8. **NOTE:** Taking return air from the back of the furnace is not permitted.

DUCTING

▲ WARNING

UPFLOW FURNACE: THE SOLID METAL BASE PLATE (SHIPPED WITH THE FURNACE) MUST BE INSTALLED IN THE FURNACE BOTTOM WHEN USING SIDE AIR RETURN. FAILURE TO INSTALL A BASE PLATE COULD CAUSE THE PRODUCTS OF COMBUSTION TO CIRCULATE INTO THE LIVING SPACE AND CREATE POTENTIALLY HAZARDOUS CONDITIONS, INCLUDING CARBON MONOXIDE POISONING OR DEATH. FOR BOTTOM RETURN, A SOLID METAL BASE PAN MUST NOT BE INSTALLED.

NOTE: DO NOT take return air from furnace rooms, garages or cold areas. Avoid return air from utility rooms, kitchens, laundry rooms and bathrooms.

DOWNFLOW INSTALLATIONS

1. Position the unit to minimize long runs of duct or runs of duct with many turns and elbows.
2. If summer air conditioning is desired, position the indoor coil on the supply-air side of the unit. Ensure that no air can bypass this coil.
3. If installing on a combustible floor and not using an air conditioning plenum, install the special non-combustible floor base. See Table 1 and Figure 12.
4. Connect the furnace to the supply air plenum.
5. Connect the return air ducting to the return air opening at the top of the unit. Make the connection air tight

▲ WARNING

A DOWNFLOW INSTALLATION IS CERTIFIED FOR INSTALLATION ON A NON-COMBUSTIBLE FLOOR. USE THE SPECIAL BASE SPECIFIED ON THE FURNACE CLEARANCE LABEL. FAILURE TO INSTALL THE SPECIAL BASE MAY RESULT IN FIRE, PROPERTY DAMAGE, PERSONAL INJURY OR DEATH. THIS BASE IS AVAILABLE AS AN ACCESSORY.

to prevent the migration of toxic fumes and odors including carbon monoxide from migrating into the living space from an adjacent fuel-burning appliance.

NOTE: In downflow configuration, side return air cut out is not permitted. Do **NOT** take return air from the back of the unit.

6. If a filter is installed near the furnace, be sure to have adequate space for installation and removal of the unit filter.

NOTE: DO NOT take return air from furnace rooms, garages or cold areas. Avoid return air from utility rooms, kitchens, laundry rooms and bathrooms.

HORIZONTAL INSTALLATIONS

1. Position the unit to minimize long runs of duct or runs of duct with many turns and elbows.

FIGURE 9

① REMOVE BLOWER DOOR AS SHOWN

② INSERT TAB ONTO FLANGE AND PUSH PANEL INTO PLACE

③ INSTALL SCREW IN TAB LOCATED IN THE BLOWER COMPARTMENT TAPE ALL EDGES OF BOTTOM TO COVER GAPS

④ AFTER INSTALLATION OF BOTTOM PLATE, SEAL ALL SEAMS TIGHT WITH METAL TAPE

INTERNAL VIEW OF BLOWER COMPARTMENT

RETAINING TAB DETAIL

INSTALLATION OF SOLID METAL BASE FOR SIDE RETURN APPLICATIONS

ST-A1194-49

2. If summer air conditioning is desired, position the indoor coil on the supply air side of the unit. Ensure that no air can bypass this coil.
3. Connect the furnace to the supply air plenum.
4. Connect the return air ducting to the return air opening at the return-air end of the unit. Make the connection air tight to prevent the migration of toxic fumes and odors including carbon monoxide from migrating into the living space from an adjacent fuel-burning appliance.

NOTE: In horizontal configuration, side return air cut out is not permitted. Do **NOT** take return air from the back of the unit.

5. If a filter is installed near the furnace, be sure to have adequate space for installation and removal of the unit filter.

FIGURE 10

FLANGE BENDING INSTRUCTIONS **INSTALLER BENT - UP**
AS - SHIPPED FLAT **ALTERNATE - BENT (DOWN)**
(ALTERNATE - BENT DOWN)

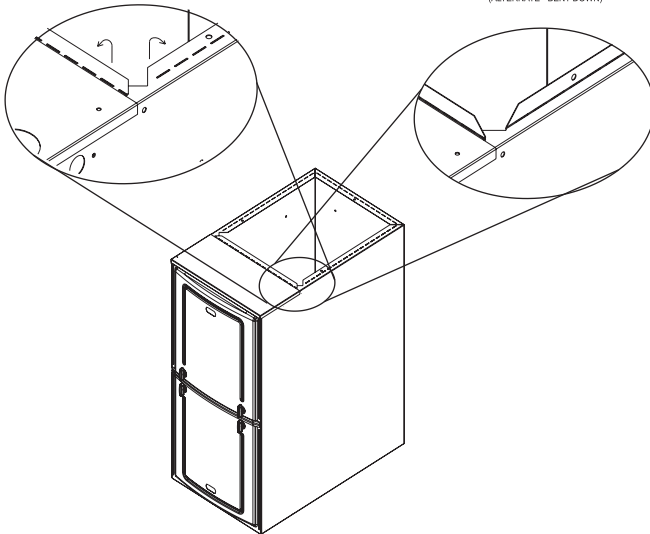

NOTES:
 THIS VIEW IS REPRESENTATIVE OF BOTH SUPPLY AND RETURN OPENINGS.
 DUCT FLANGES MUST BE FIELD - BENT ALONG PERFORATIONS EITHER INTO OR OUT OF THE FURNACE AS NECESSARY FOR INSTALLATIONS BUT **NEITHER FLANGE CAN REMAIN FLAT.**
 INSTALLER SHOULD USE DUCK BILLED PLIERS (AKA: FOLDING PLIERS) TO BEND THE FLANGE ALONG THE PERFORATIONS.

ST-A1194-39-00

TABLE 1
NON-COMBUSTIBLE FLOOR BASES

MODELS	DIM. A	DIM. B	FILTER SIZE
RXGF-F17	17.5"	15.0"	16.0" X 25.0"
RXGF-F21	21.0"	18.5"	20.0" X 25.0"
RXGF-F24	24.5"	22.0"	20.0" X 25.0"

FIGURE 11

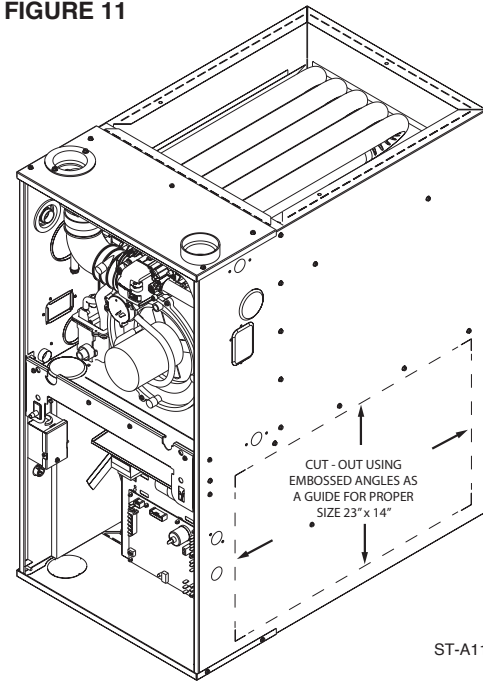

ST-A1194-04-X0

NOTE: DO NOT take return air from furnace rooms, garages or cold areas. Avoid return air from utility rooms, kitchens, laundry rooms and bathrooms.

FIGURE 12
NON-COMBUSTIBLE FLOOR BASE INSTALLATION INSTRUCTIONS

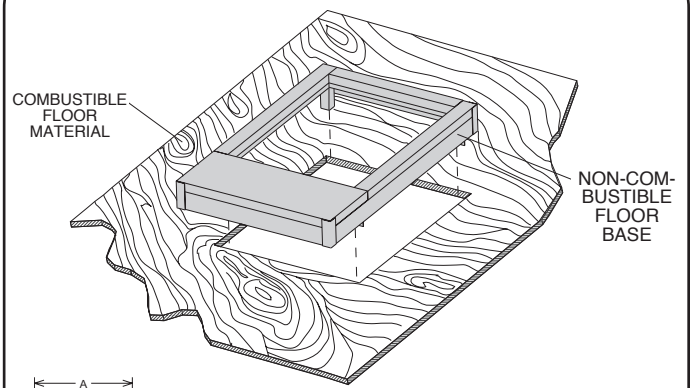

FLOOR CUTOUT DIMENSIONS

MODELS	DIM. A	DIM. B	FILTER SIZE
RXGF-F17	17.5"	15.0"	16.0" X 25.0"
RXGF-F21	21.0"	18.5"	20.0" X 25.0"
RXGF-F24	24.5"	22.0"	20.0" X 25.0"

ST-A1194-43-00

GENERAL VENTING REQUIREMENTS AND GUIDELINES

VENTING & COMBUSTION AIR REQUIREMENTS

WARNING

READ AND FOLLOW ALL INSTRUCTIONS IN THIS SECTION. FAILURE TO PROPERLY VENT THIS FURNACE CAN CAUSE CARBON MONOXIDE POISONING, OR AN EXPLOSION OR FIRE, RESULTING IN PROPERTY DAMAGE, PERSONAL INJURY OR DEATH.

WARNING

THIS FURNACE AND ANY OTHER FUEL-BURNING APPLIANCE MUST BE PROVIDED WITH ENOUGH FRESH AIR FOR PROPER COMBUSTION AND VENTILATION OF THE FLUE GASES. MOST BUILDINGS WILL REQUIRE THAT OUTSIDE AIR BE SUPPLIED INTO THE FURNACE AREA. FAILURE TO DO SO CAN CAUSE PERSONAL INJURY OR DEATH FROM CARBON MONOXIDE POISONING. REFER TO SECTION TITLED “NON-DIRECT VENTING” TO DETERMINE IF THE FURNACE MUST USE OUTSIDE AIR FOR COMBUSTION.

This furnace removes both sensible and latent heat from the combustion gases. Removal of latent heat results in the condensation of flue gas water vapor. This condensed water vapor drains from the secondary heat exchanger and out of the unit into the drain trap.

When installed as a non-direct vent furnace, only exhaust piping is required and inside combustion air may be used. Refer to the section on “NON-DIRECT VENTING.”

Direct vent installations require a dedicated combustion air and venting system. All air for combustion is taken from the outside atmosphere and all combustion products are discharged to the outdoors.

Adequate facilities for providing air for combustion and ventilation must be provided in accordance with Section 5.3, “Air for Combustion and Ventilation” of the National Fuel Gas Code, ANSI Z223.1 (latest edition), in Canada CSA B149.1; Canadian Natural Gas and Propane Installation Code and The National Fire Code of Canada, or applicable provisions for the local building codes, and not obstructed so as to prevent the flow of air to the furnace.

IMPORTANT: Air for combustion and ventilation must not come from a corrosive atmosphere. Any failure due to corrosive elements in the atmosphere is excluded from the warranty coverage.

Combustion air must be free of acid-forming chemicals such as sulfur, fluorine and chlorine. These elements are found in aerosol sprays, detergents, bleaches, cleaning solvents, air fresheners, paint and varnish removers, refrigerants and many other commercial and household products. When burned in a gas flame, vapors from these products form acid compounds. The acid compounds increase the dew point temperature of the flue products and are highly corrosive after they condense.

The following types of installations (but not limited to the following) may require outdoor air for combustion (direct vent) due to chemical exposures:

- Commercial buildings
- Buildings with indoor pools
- Furnaces installed in laundry rooms
- Furnaces in hobby or craft rooms
- Furnaces installed near chemical storage areas

If combustion air is exposed to the following substances (but not limited to the following), it should not be used and the furnace may require outdoor air for combustion (direct vent).

- Permanent wave solutions
- Chlorinated waxes and cleaners
- Chlorine-based swimming pool chemicals
- Water softening chemicals
- De-icing salts or chemicals
- Carbon tetrachloride
- Halogen type refrigerants
- Printing inks, paint removers, varnishes etc.
- Cleaning solvents (such as perchloroethylene)
- Hydrochloric acid
- Cements and glues
- Antistatic fabric softeners for clothes dryers
- Masonry curing and acid washing materials

WARNING

ALL FURNACE INSTALLATIONS MUST COMPLY WITH THE NATIONAL FUEL GAS CODE, IN CANADA CSA B149.1; CANADIAN NATURAL GAS AND PROPANE INSTALLATION CODE AND THE NATIONAL FIRE CODE OF CANADA, NFPA 54 AND LOCAL CODES TO PROVIDE ADEQUATE COMBUSTION AND VENTILATION AIR FOR THE FURNACE. FAILURE TO DO SO CAN RESULT IN EXPLOSION, FIRE, PROPERTY DAMAGE, CARBON MONOXIDE POISONING, PERSONAL INJURY OR DEATH.

Combustion air requirements are determined by whether the furnace is in an open (unconfined) area or in a confined space such as a closet or small room.

When the furnace is installed in the same space with other gas appliances, such as a water heater, be sure there is an adequate supply of combustion and ventilation air for the furnace and the other appliances. Do not delete or reduce the combustion air supply required by the other gas appliances in this space. See Z223.1, National Fuel Gas Code (NFPA 54), in Canada CSA B149.1; Canadian Natural Gas and Propane Installation Code and The National Fire Code of Canada, for determining the combustion air requirements for gas appliances. An unconfined space must have at least 50 cubic feet (volume) for each 1,000 BTUH of the total input of all appliances in the space. If the open space containing the appliances is in a building with tight construction (contemporary construction), outside air may still be required for the appliances to burn and vent properly. Outside air openings should be sized the same as for a confined space.

GENERAL VENTING REQUIREMENTS AND GUIDELINES

VENTING & COMBUSTION AIR REQUIREMENTS (cont.)

IMPORTANT: ONLY THE CURRENT VENT INSTRUCTIONS APPLY. All 90 Plus Gas Furnaces cannot be common-vented.

OVER TEMPERATURE SAFETY SWITCHES

Furnaces are equipped with safety switches in the burner compartment to protect against over-temperature conditions caused by inadequate combustion air supply. The switches are located in the burner compartment. If a switch is tripped it must be manually reset after clearing the fault condition which caused it to open.

WARNING

DO NOT BYPASS, JUMPER, OR REMOVE ANY SAFETY SWITCH FROM THE FURNACE CONTROL CIRCUIT. IF A SAFETY SWITCH CAUSES THE FURNACE TO SHUT DOWN OR OPERATE INTERMITTENTLY, IT IS AN INDICATION OF A POTENTIAL SAFETY HAZARD THAT MUST BE ADDRESSED BY A QUALIFIED TECHNICIAN, SERVICE AGENCY OR THE GAS SUPPLIER. DO NOT RESET SAFETY CONTROLS WITHOUT CORRECTIVE ACTION AND/OR VERIFICATION OF PROPER SAFE OPERATION BY A QUALIFIED INSTALLER, SERVICE AGENCY OR THE GAS SUPPLIER.

REPLACE ANY SAFETY CONTROL COMPONENT ONLY WITH IDENTICAL OEM REPLACEMENT PARTS

MATERIAL REQUIREMENTS PIPING REQUIREMENTS

Vent materials can be of a plastic type if they provide the proper temperature and corrosive resistance pvc schedule 40 pipe per ASTM D1785 and fittings sized per D2466. Other plastics can be used per UL-1738c.

NOTE: Cellular core PVC is NOT approved for use. Each run of venting must be made by the same material and manufacturer. Joints must be made per the manufacturer's specified method. Do not use cements and adhesives not approved for your application.

NOTE: Material, primer, solvent-cement certified to UL 1738 is also approved for use. The material products must be the same dimensionally as material described in this section, and installed in accordance with the manufacturer's specific venting and combustion air requirements listed in this section, to ensure the system is installed per UL 1738 certification and other applicable standards.

1. All horizontal piping must slope upward from the furnace with a minimum slope of ¼ inch per foot of horizontal vent so that condensate drains back toward the furnace.
2. All horizontal runs must be supported at least every 4 feet. No sags or dips are permitted.
3. **IMPORTANT:** Do not common vent with any other appliance. Do not install in the same chase or chimney

with a metal or high temperature plastic pipe from another gas or fuel-burning appliance unless the required minimum clearances to combustibles are maintained between the plastic pipe and other pipes. For Canada PVC, CPVC and polypropylene can be used as long as they conform with ULCS-636C requirements.

4. All vent installed through unconditioned spaces where below-freezing temperatures are expected must be insulated with an approved insulating material. Materials such as Armaflex or Rubatex insulation may also be used as long as there is no heat tape applied to the vent pipe. For horizontal runs where water may collect, wrap the vent pipe with self-regulating 3 watt or 6 watt heat tape. The heat tape must be U.L. listed and installed per the manufacturer's instructions.
NOTE: Never cover heat tape with insulation.

WARNING

IN CANADA, PRODUCTS CERTIFIED FOR INSTALLATION AND INTENDED TO BE VENTED WITH PLASTIC VENT SYSTEMS (PVC, CPVC & POLYPROPYLENE) MUST USE VENT SYSTEMS THAT ARE CERTIFIED TO THE STANDARD FOR TYPE BH GAS VENTING SYSTEMS, ULC S636.

THE COMPONENTS OF THE CERTIFIED MATERIAL MUST NOT BE INTERCHANGED WITH OTHER VENT SYSTEMS OR UNLISTED PIPE/FITTINGS.

PLASTIC COMPONENTS AND SPECIFIED PRIMERS AND GLUES OF THE CERTIFIED SYSTEM MUST BE FROM A SINGLE SYSTEM MANUFACTURER AND NOT INTERMIXED WITH OTHER SYSTEM MANUFACTURER'S PARTS.

VENT TERMINATIONS ARE NOT REQUIRED TO BE FROM THE SAME MANUFACTURER AS THE REST OF THE VENTING BUT VENT TERMINATIONS MUST BE ULC S636 APPROVED.

NOTE: WITH THE EXCEPTION OF THE TERMINATION INLET AIR PIPING IS NOT CONSIDERED TO BE A PART OF THE "VENTING SYSTEM". THE REQUIREMENT THAT VENT MATERIAL BE CERTIFIED TO ULC S636 DOES NOT APPLY TO INLET AIR PIPING.

REGARDLESS, ALL TERMINATIONS ON BOTH INLET AND OUTLET PIPES MUST BE CONSTRUCTED FROM COMPONENTS BUILT TO ULC-S636 REQUIREMENTS.

5. The minimum vent pipe length is 5 feet [1.5m].
6. **IMPORTANT:** No part of the combustion air and/or vent pipes may be installed underground.
7. Piping at a roof, wall or other penetration must be immobilized to prevent pipes from disconnecting. Disconnected pipes may allow flue products to be released inside the structure.
8. For Direct Vent systems, all pipe penetrations through roof or sidewall must be installed so that the vent and

GENERAL VENTING REQUIREMENTS AND GUIDELINES

VENTING & COMBUSTION AIR REQUIREMENTS (cont.)

combustion air intake pipes terminate in the same atmospheric pressure zone.

9. Vent terminations must be installed with the minimum clearances specified in the TERMINATION REQUIREMENTS sections of this manual and **Figure 22** (for Non-Direct Vent) and **Figure 33** (for direct Vent installations).
10. Piping external to the structure (excluding approved venting terminations) and vent passing through unheated crawl-spaces, attics, verandas, patios or decks must be insulated with approved insulating material to prevent freezing as required for local climate.

WARNING

PVC/CPVC SOLVENT CEMENTS AND PRIMERS ARE HIGHLY FLAMMABLE. PROVIDE ADEQUATE VENTILATION AND DO NOT ASSEMBLE NEAR A HEAT SOURCE OR AN OPEN FLAME. DO NOT SMOKE. AVOID SKIN OR EYE CONTACT. OBSERVE ALL CAUTIONS AND WARNINGS PRINTED ON MATERIAL CONTAINERS. FAILURE TO FOLLOW THESE GUIDELINES MAY RESULT IN FIRE, EXPLOSION OR ASPHYXIATION CAUSING PERSONAL INJURY OR DEATH.

TABLE 2
APPLICABLE ASTM STANDARDS FOR VENT MATERIALS

Materials	Sch. 40 Pipe	SDR Pipe	Fittings	Primer	Solv. Cement
ABS	D1527	-	D2468 & D2661	-	D2235
PVC	D1785	D2241	D2466 & D2665	F656	D2564
CPVC	F441	F442	F348	-	F493
ABS to PVC	-	-	-	-	D3138

For Canadian installations all exhaust venting materials must be certified to ULCS-636C.

GENERAL VENTING REQUIREMENTS AND GUIDELINES

VENT PIPE SIZING AND MAXIMUM VENT LENGTHS

EQUIVALENT VENT LENGTHS

The concept of equivalent vent lengths is frequently used in piping systems to account for pressure drop of fittings, such as elbows. The equivalent length of a fitting is the length of a straight section of pipe that has an equivalent pressure drop in the application as the fitting used. With the equivalent length vent concept, a vent system can use up to the maximum number of elbows and vent length of straight pipe as long as the maximum equivalent vent length is not exceeded.

There are several different types of elbows that can be used when constructing a vent system. **Figure 13** shows the standard dimensions for standard and long-sweep 90° (1/4 turn) elbows as specified by ASTM 3311, Standard Specification for Drain, Waste and Vent (DWV) Plastic Fittings Patterns.

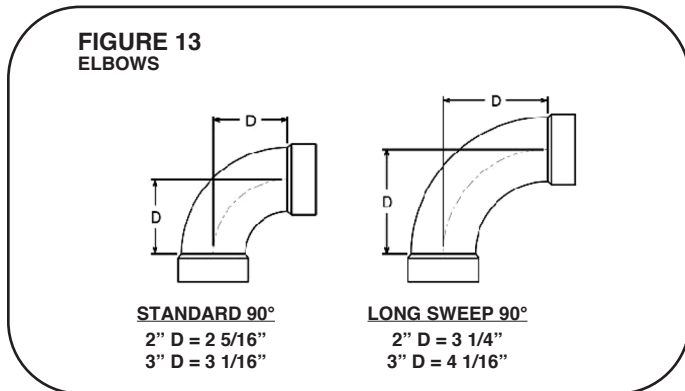

A long-sweep (AKA Long-Radius) 90° (1/4 turn) elbow has an equivalent vent length of 5 feet of straight pipe for either 2 inch or 3 inch plastic pipe. A standard 90° elbow has an equivalent vent length of 10 feet of straight pipe. This equivalent length can be used in circumstances where it might be necessary to lengthen the vent at the outside of the structure, such as in areas with large accumulations of snow in winter. **Table 3** shows the equivalent lengths of different types of elbows.

Fitting Type	Equivalent Length
90° Standard Elbow	10 Feet of Pipe
45° Long-Sweep Elbow	2-1/2 Feet of Pipe
90° Long-Sweep Elbow	5 Feet of Pipe

Table 4 specifies the equivalent maximum vent lengths specified by the manufacturer for each furnace. Listed table maximums have been qualified by the manufacturer. Dependant on individual installation specifics, installations beyond the table recommendations may cause erratic pressure switch operation.

Examples:

1. A 60KBTU direct-vent installation needs a 31 foot long vent run with qty=5, 90° long-sweep elbows and 2 inch pipe.

$$31 \text{ feet of 2 inch pipe} = 31 \text{ equivalent feet}$$

$$\text{Qty} = 5, 90^\circ \text{ long-sweep elbows} = 25 \text{ equivalent feet}$$

$$\text{Total} = 56 \text{ equivalent feet}$$

Since the maximum equivalent vent length specified for a 60KBTU furnace is 65 feet, this installation is acceptable.

2. If the installation from Example 1 were installed with standard elbows instead of long-sweep elbows, the calculation would be as follows:

$$31 \text{ feet of 2 inch pipe} = 31 \text{ equivalent feet}$$

$$\text{Qty} = 5, 90^\circ \text{ standard elbows} = 50 \text{ equivalent feet}$$

$$\text{Total} = 81 \text{ equivalent feet}$$

This installation is NOT acceptable as it exceeds the 65 foot maximum specified for this model.

GENERAL VENTING REQUIREMENTS AND GUIDELINES

VENT PIPE SIZING AND MAXIMUM VENT LENGTHS (cont.)

Venting

TABLE 4: MAXIMUM EQUIVALENT VENT LENGTH (TABLE IS FOR BOTH DIRECT & NON-DIRECT VENTING)			
Input (BTU/H)	Pipe Size	Maximum Equivalent Length (Feet)	Recommended Maximum Number of Elbows
42,000	2 inchØ	65	6
	3 inchØ	100	6
56,000	2 inchØ	65	6
	3 inchØ	100	6
70,000	2 inchØ	65	6
	3 inchØ	100	6
70,000 5 ton 21" cabinet	2 inchØ	65 (except hz right 50)	6
	3 inchØ	100 (except horizontal right 85)	6
84,000	2 inchØ	30	2
	3 inchØ	100	6
98,000	2 inchØ	20	2**
	3 inchØ	100	6
112,000	2 inchØ	20	2**
	3 inchØ	85	6
<p>NOTE: The elbows needed for the vent termination are not counted in these lengths except at altitudes above 6,000 feet. Above 6,000 feet alternate horizontal vent termination elbows are to be included in the equivalent vent length.</p> <p>* This is the recommended maximum number of long sweep elbows for either 2 or 3 inch pipe. Combinations of long sweep 90s, standard 90s, or 45s may be used, but the manufacturer recommends the use of long sweep 90s whenever possible because the use of the maximum number of standard 90 and 45 elbows only may result in nuisance furnace outages due to individual installation specifics. Exceeding the recommended maximum number of elbows may cause nuisance operation of the pressure switch.</p> <p>** Not applicable for alternate terminations.</p>			

NOTE: If the vent length exceeds the maximum equivalent length specified for 2" pipe, then the transition from 2" to 3" needs to be within 2 feet of the unit.

GENERAL VENTING REQUIREMENTS AND GUIDELINES

VENT PIPE SIZING AND MAXIMUM VENT LENGTHS (cont.)

POLYPROPYLENE VENT PRODUCTS

Centrotherm brand *Innoflue* and Duravent *Polypro* Single-wall and flex venting products are approved for use on this furnace product only in single appliance applications. Do not exceed maximum venting lengths, diameters or elbows listed in these instructions (**Vent Pipe Sizing and Maximum Vent Lengths** section [Table 4]). Application of these products is limited to the terminations listed in Tables 5 and 6 below. These manufacturers have provisions

for B-vent liners and chimney liners which can be used with this furnace with non-direct venting applications only. Refer to the manufacturer's installation instructions for proper installation. Contact the manufacturer for all installation and application information.

NOTE: These venting products are listed for use in Canada under ULC-S636.

TABLE 5: DURAVENT BRAND POLYPRO & POLYPRO FLEX TERMINATION COMPONENTS

2" VENT	3" VENT	Description
2PPS-HTP	3PPS-HTP	Horizontal Direct-Vent Termination
2PPS-HST	3PPS-HST	Horizontal Non-Direct Termination
2PPS-VK, 2PPS-VK-TC	3PPS-VK, 3PPS-VK-TC	Vertical Concentric Kits
2PPS-HK	3PPS-HK	Horizontal Concentric Kits
2PPS-FK	3PPS-FK	Flex Chimney Lining Kit
2PPS-VFT	3PPS-VFT	Vertical Flex Termination Cap
2PPS-BV4, 2PPS-BV5, 2PPS-BV6	3PPS-BV5, 3PPS-BV6	B-VENT Adapter

TABLE 6: CENTROTHERM BRAND ECO SYSTEMS TERMINATION COMPONENTS

2" VENT	3" VENT	Description	Notes
ISCP02	ISCP03	Chimney Cover	For Use on Non-Direct Vent only. DO NOT use with a Direct-Vent Installation.
NA	ISCM03	Stainless Steel Chimney Cover	For Use on Non-Direct Vent only. DO NOT use with a Direct-Vent Installation.
IABC0204 thru IABC0207	IABC0304 thru IABC0307	B-Vent Rain Collar	For Use on on Non-Direct Vent only. DO NOT use with a Direct-Vent Installation.
ISLPT0202	ISLPT0303	Low-Profile Wall Termination	
ISTT0220	ISTT0320	Termination Tee	
ISEP02 & ISEP0239	ISEP03 & ISEP0339	End Pipe	
IFEPO2	NA	2" Flex End Pipe	
NA	ICWT352	Plastic Concentric Wall Termination	Approved for Direct-Vent
ICW2413	ICW3513	Stainless Steel Concentric Wall Termination	Approved for Direct-Vent
ICRT2439	ICRT3539	Concentric Roof (Vertical) Termination	Approved for Direct-Vent

GENERAL VENTING REQUIREMENTS AND GUIDELINES

TERMINATION REQUIREMENTS

CAUTION

THE COMBUSTION PRODUCTS AND MOISTURE IN THE FLUE GASES WILL CONDENSE AS THEY LEAVE THE TERMINATION. THE CONDENSATE CAN FREEZE ON THE EXTERIOR WALL, UNDER THE EAVES AND ON SURROUNDING OBJECTS. SOME DISCOLORATION TO THE EXTERIOR OF THE BUILDING IS TO BE EXPECTED. HOWEVER, IMPROPER LOCATION OR INSTALLATION CAN RESULT IN FINISH DAMAGE TO THE BUILDING AND MAY RE-CIRCULATE THE PRODUCTS OF COMBUSTION INTO THE COMBUSTION AIR TERMINAL AND FREEZE.

Vent terminations for both Non-Direct and Direct-Vent installations must adhere to guidelines specified by the latest edition of ANSI Z21.47 **Gas-Fired Central Furnaces**. These are clearly detailed in **Figure 22** for Non-Direct-Vent installations and **Figure 33** for Direct-Vent installations. In addition to these requirements, the installation and venting must also comply with the National Fuel Gas Code (U.S.) and CSA-B149.1; Canadian Natural Gas and Propane Installation Code (Canada) and the following requirements must also be met:

NOTE: Screens of any kind on the inlet or exhaust pipes are not permitted and will void the manufacturer's warranty.

In addition to the requirements shown in **Figure 22** for Non-Direct venting and **Figure 33** for Direct-Venting, the vent must be installed with the following minimum clearances:

1. The vent terminal shall have a specified minimum horizontal clearance from electric meters, gas meters, regulators and relief equipment. See the National Fuel Gas Code for specific distances or CSA B149.1 in Canada as these distances may vary by location.
 2. Locate the furnace combustion air inlet away from the vent of any other gas or fuel-burning appliance or clothes dryer to prevent recirculation of the flue gases into the furnace combustion air inlet. For exact distances based on BTU of appliances refer to National Fuel Gas Code or CSA B149.1 in Canada. The only exception to this requirement is the case of multiventing two or more furnaces, which is covered in the section on multiventing of these instructions.
- In addition to the minimum clearances listed above and in **Figure 22** (Non-Direct Vent) and **Figure 33** (Direct-Vent), the vent location should also be governed by the following guidelines.
1. Avoid terminating under any kind of patio or deck. However, if necessary, vent piping may be installed under a deck as long as the termination(s) is (are) not under the deck.
 2. If installing the vent under a deck, insulate it to insure that no condensate freezes and blocks the pipes.
 3. Do not terminate in any area or behind any obstruction that may allow the flue products to become stagnant and/or re-circulate.
 4. Do not locate on the side of a building with prevailing winter winds. This will help prevent moisture from freezing on the walls and overhangs (under eaves).
 5. If extending vent through a brick or masonry surface, a sleeve between the wall and venting is suggested to protect against damage from thermal expansion and contraction.
 6. A corrosion-resistant sheet metal or plastic backing plate installed on the wall behind the vent is suggested to prevent exhaust gases and condensate from contacting the wall.
 7. Avoid locating too close to shrubs as condensate may stunt growth or kill them.

GENERAL VENTING REQUIREMENTS AND GUIDELINES

NON-DIRECT VENT

WARNING

ALL FURNACE INSTALLATIONS MUST COMPLY WITH THE NATIONAL FUEL GAS CODE, NFPA 54, AND IN CANADA CSA B149.1; CANADIAN NATURAL GAS AND PROPANE INSTALLATION CODE, THE NATIONAL FIRE CODE OF CANADA, AND LOCAL CODES TO PROVIDE ADEQUATE COMBUSTION AND VENTILATION AIR FOR THE FURNACE. FAILURE TO DO SO CAN RESULT IN EXPLOSION, FIRE, PROPERTY DAMAGE, CARBON MONOXIDE POISONING, PERSONAL INJURY OR DEATH.

For improved indoor air quality, added safety and product performance we recommend direct vent type installations. If non-direct type vent system is used, the requirements for combustion air must be provided as identified in the National Fuel Gas Code and, in Canada, CSA B149.1; Canadian Natural Gas and Propane Installation Code.

Combustion air requirements are determined by whether the furnace is in an open (unconfined) area or in a confined space such as a closet or small room.

WARNING

READ AND FOLLOW THE **GENERAL VENTING REQUIREMENTS AND GUIDELINES** OF THIS MANUAL FOR ADDITIONAL VENTING REQUIREMENTS PERTAINING TO ALL FURNACE INSTALLATIONS (INCLUDING DIRECT AND NON-DIRECT VENTING). FAILURE TO FOLLOW ALL INSTRUCTIONS IN THIS MANUAL CAN RESULT IN EQUIPMENT FAILURE, EQUIPMENT DAMAGE, PROPERTY DAMAGE, PERSONAL INJURY OR DEATH.

CONFINED AND UNCONFINED SPACES

The below instructions are for U.S. installations only. The terms **Confined Space** and **Unconfined Space** refer to U.S. installations only. In Canada the proper term to use is **Enclosure** when specifying that a furnace is installed in a partially enclosed or fully enclosed room or space. For Canadian installations, to determine combustion air requirements for non-direct vent installations, the installer must follow CSA B149.1; Canadian Natural Gas and Propane Installation Code and NOT the below instructions.

TABLE 7: MINIMUM SPACE REQUIREMENTS FOR UNCONFINED SPACE, NON-DIRECT VENT

Input (BTUH)	Minimum Space (Cubic Ft)	Minimum Area with 8ft Ceilings (sq ft)	Typical Room Size w/ 8' Ceilings (ft x ft)
42,000	2,100	263	14 x 20
56,000	2,800	350	18 x 20
70,000	3,500	438	22 x 20
84,000	4,200	525	25 x 20
98,000	4,900	613	20 x 30
112,000	5,600	700	25 x 30

FURNACE LOCATED IN AN UNCONFINED SPACE (U.S. INSTALLATIONS) USING INDOOR AIR FOR COMBUSTION:

An unconfined space must have at least 50 cubic feet for each 1,000 BTUH of total input for all appliances in the space. **Table 7** below specifies minimum space requirements and a few examples of the room sizes required for different inputs. The sizes are based on 8-foot ceilings.

If the open space containing the furnace is in a building with tight construction, outside air may still be required for the furnace to operate and vent properly. Outside air openings should be sized the same as for a confined space.

FURNACE LOCATED IN A CONFINED SPACE (U.S. INSTALLATIONS)

A confined space is defined as any space for a given furnace input rating which is smaller than that which is specified in **Table 7** as minimum for an "unconfined" space. If the space is less than that specified in this table, the space is defined as "confined".

If the space is small enough to be designated as "confined", it must have openings into the space which are located in accordance with the requirements set forth in the following subsections A and B. Size connected to the heated area or to the outside, and by the input of **ALL** appliances in the space.

If the confined space is within a building with tight construction, combustion air must be taken from outdoors or from an area freely communicating with the outdoors.

A. USING INDOOR AIR FOR COMBUSTION:

IMPORTANT: Air should not be taken from a heated space with a fireplace, exhaust fan or other device that may produce negative pressure.

If combustion air is taken from the heated area, the openings must each have at least 100 square inches of free area. Each opening must have at least one square inch of free area for each 1,000 BTUH of total input in the space. **Table 8** shows some typical examples of openings required for combustion air openings required for a confined space.

TABLE 8: MINIMUM FREE AREA OPENING REQUIRED FOR A FURNACE LOCATED IN A CONFINED SPACE USING INDOOR AIR FOR COMBUSTION.

Input (BTUH)	Free Area for Each Opening (sq inches)
42,000	100
56,000	100
70,000	100
84,000	100
98,000	100
112,000	120

GENERAL VENTING REQUIREMENTS AND GUIDELINES

NON-DIRECT VENT (cont.)

B. USING OUTDOOR AIR FOR COMBUSTION:

IMPORTANT: Do not take air from an attic space that is equipped with power ventilation.

The confined space must communicate with the outdoors in accordance with Methods 1 or 2 below. The minimum dimension of air openings shall not be less than 3 inches. Where ducts are used, they shall be of the same cross-sectional area as the free area of the openings to which they connect.

METHOD 1:

Two permanent openings, one located within 12 inches of the top and one located within 12 inches of the bottom of the enclosure, shall be provided. The openings shall communicate directly, or by ducts, with the outdoors or spaces (crawl or attic) that freely communicate with the outdoors.

TABLE 9: MINIMUM FREE AREA REQUIRED FOR EACH OPENING (WHEN TWO OPENINGS ARE USED) WITH A FURNACE:

1. LOCATED IN A CONFINED SPACE
2. USING OUTDOOR AIR FOR COMBUSTION
3. COMMUNICATING DIRECTLY TO THE OUTSIDE THROUGH AN OPENING OR THROUGH A VERTICAL DUCT.

Total Input for ALL Gas Appliances (BTUH)	Free Area for Each Opening when 2 Separate Openings are used (sq inches)	Round Pipe Duct Diameter (Vertical Duct Only) (inches)
42,000	10	4
56,000	15	5
70,000	18	5
84,000	21	6
98,000	25	6
112,000	28	6

TABLE 10: MINIMUM FREE AREA REQUIRED FOR EACH OPENING (WHEN TWO OPENINGS ARE USED) WITH A FURNACE:

1. LOCATED IN A CONFINED SPACE
2. USING OUTDOOR AIR FOR COMBUSTION
3. COMMUNICATING DIRECTLY TO THE OUTSIDE THROUGH A HORIZONTAL DUCT.

Total Input for ALL Gas Appliances (BTUH)	Free Area for Each Opening when 2 Separate Openings are used (sq inches)	Round Pipe Duct Diameter (Horizontal Duct Only) (inches)
42,000	21	6
56,000	28	6
70,000	35	7
84,000	42	8
98,000	49	8
112,000	56	9

A. Where directly communicating with the outdoors through an opening or where communicating to the outdoors through vertical ducts as shown in **Figure 15**, each opening shall have a minimum free area of 1 square inch for each 4,000 BTUH of total appliance input rating of all equipment in the enclosure. **Table 9** below specifies the minimum area for each of the 2 combustion air openings and minimum round duct diameter for direct openings and vertical ducting only.

B. Where communicating with the outdoors through horizontal ducts, each opening shall have a minimum free area of 1 square inch for each 2,000 BTUH of total appliance input rating of all equipment in the enclosure (see **Figure 16**). **Table 10** specifies the minimum area for each of the 2 combustion air openings and minimum round duct diameter for horizontal ducting only.

METHOD 2:

One permanent opening located within 12 inches of the top

TABLE 11: MINIMUM FREE AREA REQUIRED FOR AN OPENING (WHEN ONE OPENING IS USED) WITH A FURNACE:

1. LOCATED IN A CONFINED SPACE
2. USING OUTDOOR AIR FOR COMBUSTION
3. COMMUNICATING DIRECTLY TO THE OUTSIDE.

Total Input for ALL Gas Appliances (BTUH)	Free Area for an Opening when 1 Opening is used (sq inches)	Round Pipe Duct Diameter (inches)
42,000	21	6
56,000	28	6
70,000	35	7
84,000	42	8
98,000	49	8
112,000	56	9

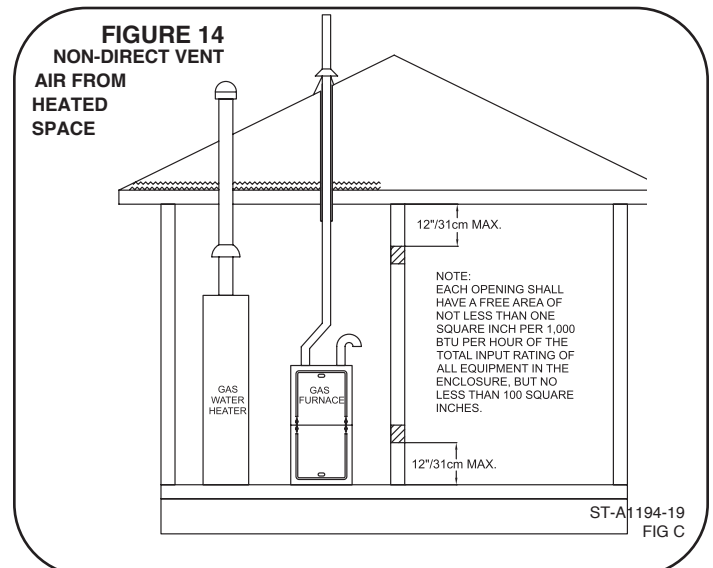

GENERAL VENTING REQUIREMENTS AND GUIDELINES

NON-DIRECT VENT (cont.)

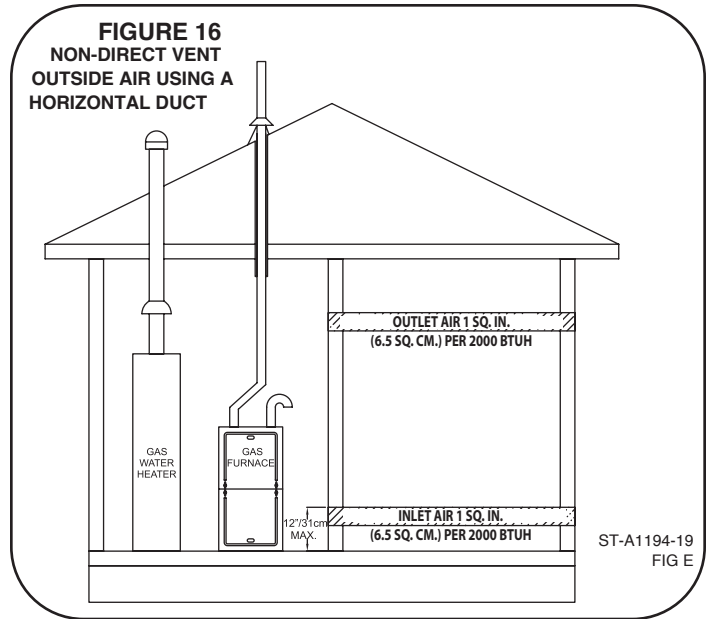
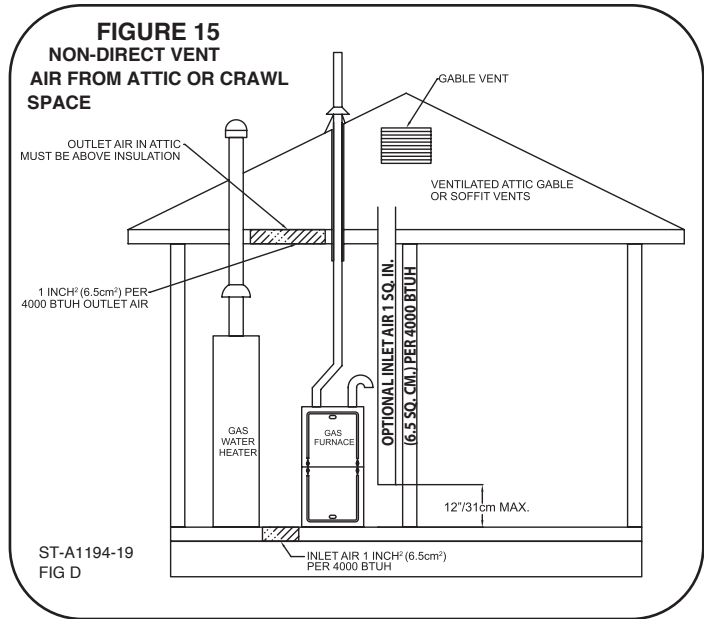

Venting

of the enclosure, shall be permitted where the equipment has clearances of at least 1 inch from the sides and back and 6 inches from the front of the appliance. The opening shall directly communicate with the outdoors or communicate through a vertical or horizontal duct to the outdoors or

spaces (crawl or attic) that freely communicate with the outdoors, and shall have a minimum of:

- A. 1 Square inch for each 3,000 BTUH of the total input rating of all equipment located in the enclosure and

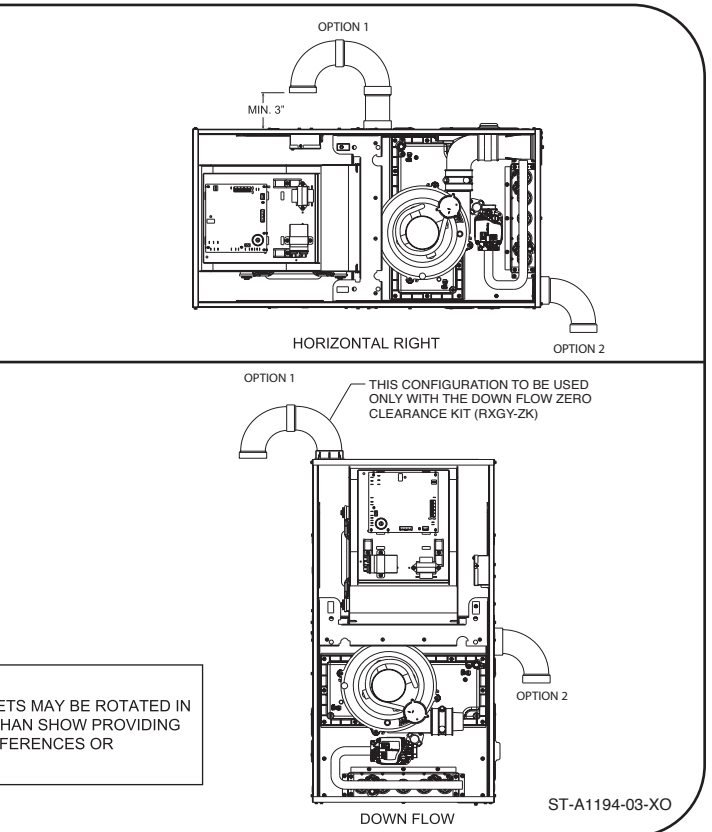
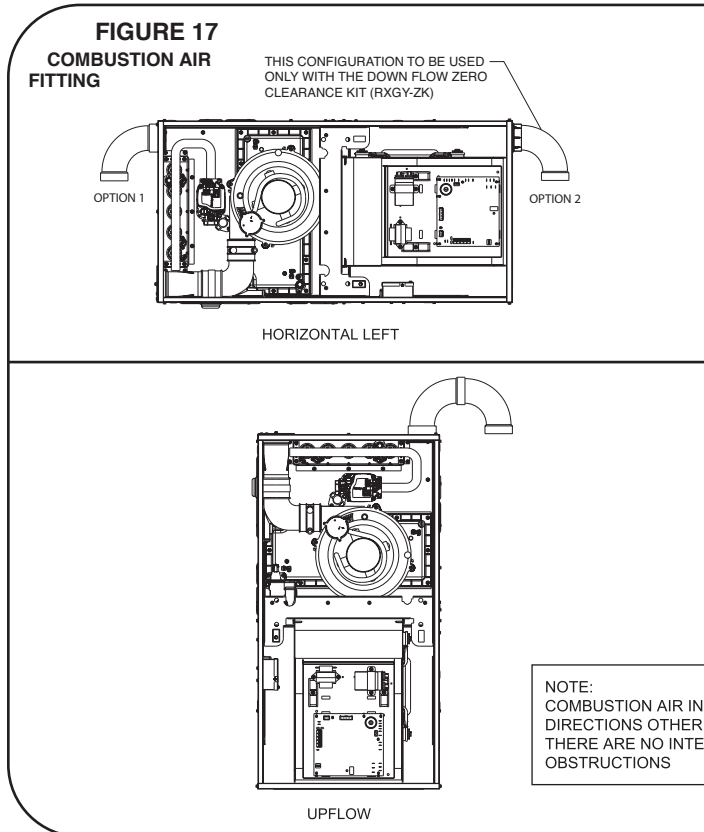

GENERAL VENTING REQUIREMENTS AND GUIDELINES

NON-DIRECT VENT (cont.)

B. Not less than the sum of the areas of all vent connectors in the confined space.

If the unit is installed where there is an exhaust fan, sufficient ventilation must be provided to prevent the exhaust fan from creating negative pressure.

Combustion air openings must not be restricted in any manner.

Figure 17 shows allowable inlet air configurations for furnaces installed with non-direct vent.

IMPORTANT: When indoor combustion air is used, the inlet air opening at the furnace must be protected from accidental blockage (see **Figure 17**).

WARNING

DO NOT USE VENT TERMINATIONS WHICH ARE NOT SPECIFIED IN THESE INSTRUCTIONS. USING VENT TERMINATIONS OTHER THAN THOSE SPECIFIED HERE CAN RESULT IN ERRATIC OPERATION, EQUIPMENT FAILURE OR PERSONAL INJURY OR DEATH FROM CARBON MONOXIDE POISONING.

NON-DIRECT VENTING TERMINATIONS

These furnaces are design-certified to use a single vent pipe where all combustion air is taken from indoors and can be vented either vertically or horizontally.

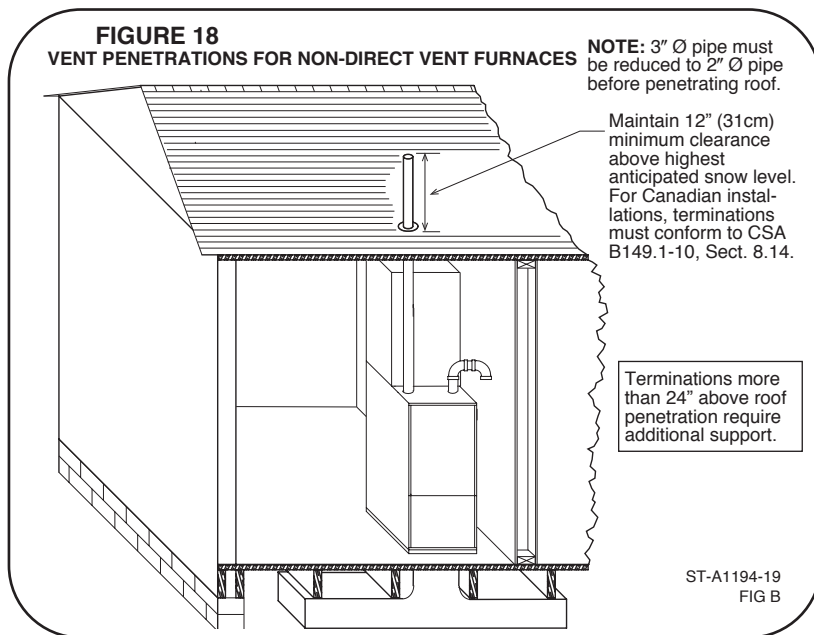

CAUTION

ALL VENTS INSTALLED THROUGH UNCONDITIONED SPACE WHERE BELOW-FREEZING TEMPERATURES ARE EXPECTED SHOULD BE INSULATED WITH APPROVED INSULATION MATERIAL. MATERIAL SUCH AS ARMAFLEX OR RUBATEX INSULATION MAY ALSO BE USED AS LONG AS THERE IS NO HEAT TAPE IS APPLIED TO THE VENT PIPE. FAILURE TO INSULATE THE PIPE COULD RESULT IN FREEZING OF WATER IN THE PIPE THEREBY BLOCKING THE PIPE AND PREVENTING FURNACE OPERATION.

OPTION 1: VERTICAL TERMINATION

Figure 18 shows a standard non-direct vertical vent termination with clearances.

OPTION 2: STANDARD HORIZONTAL TERMINATION

Figure 19 shows the standard non-direct vent horizontal termination with minimum clearances.

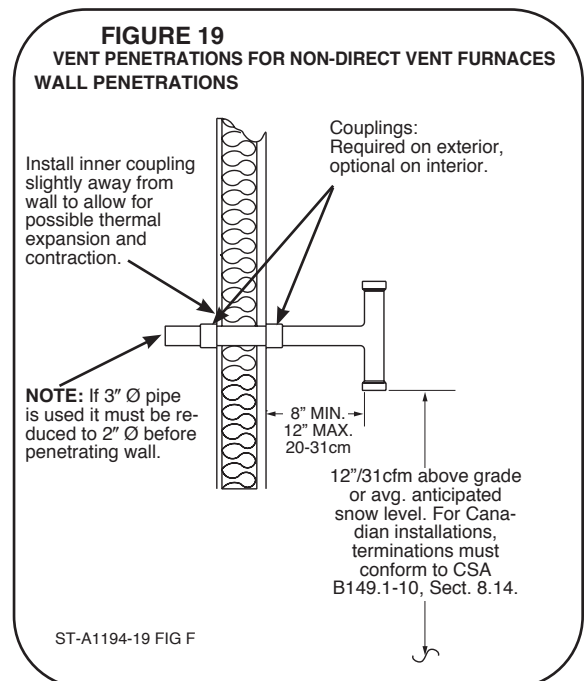

GENERAL VENTING REQUIREMENTS AND GUIDELINES

NON-DIRECT VENT (cont.)

OPTION 3: ALTERNATE HORIZONTAL TERMINATION

Figure 20 shows the alternate non-direct vent horizontal termination with minimum clearances.

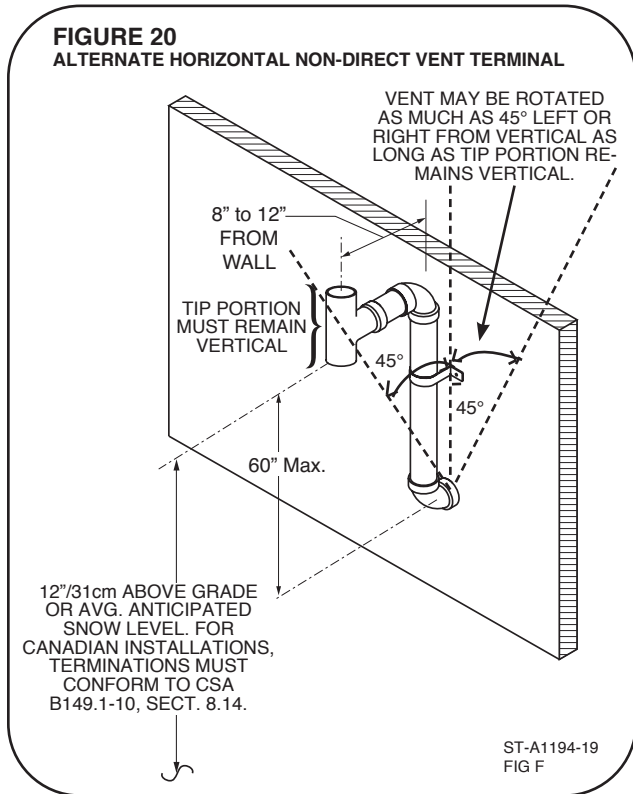

OPTION 4: RXGY-G02 SIDE WALL VENT TERMINATION

See **Figure 21** and refer to the **DIRECT VENT** Section, **OPTION 8: SIDEWALL VENT KIT** of this manual for information and directions on the side wall vent kit. The sidewall vent kit (RXGY-G02) can be used for both direct-vent and non-direct vent installations.

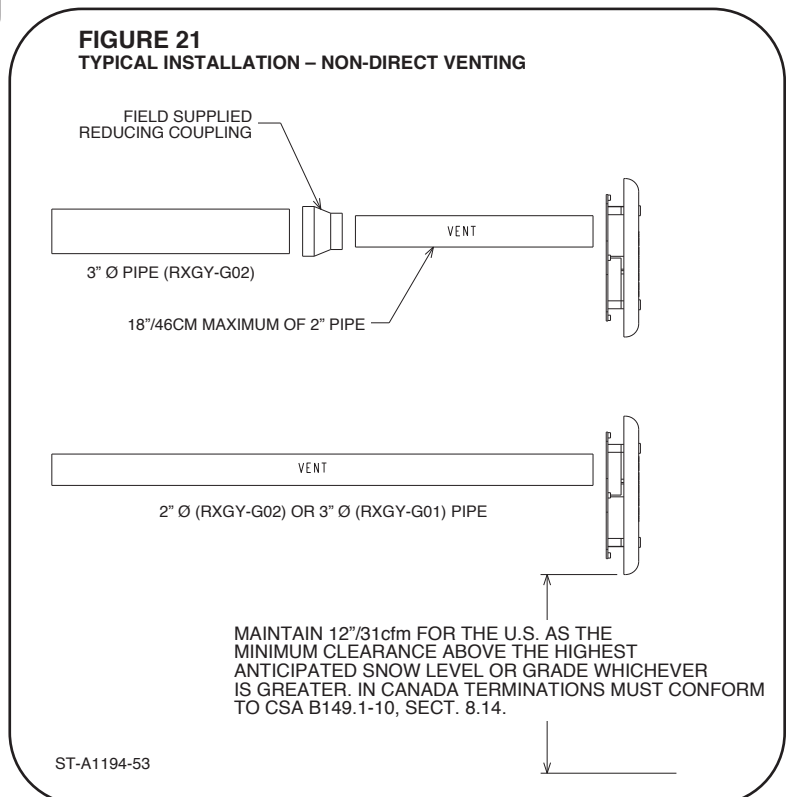

GENERAL VENTING REQUIREMENTS AND GUIDELINES

NON-DIRECT VENT TERMINATION CLEARANCES

Figure 22 shows minimum clearances that must be used for non-direct venting terminations.

FIGURE 22
VENT TERMINATION CLEARANCES FOR NON-DIRECT VENT INSTALLATIONS

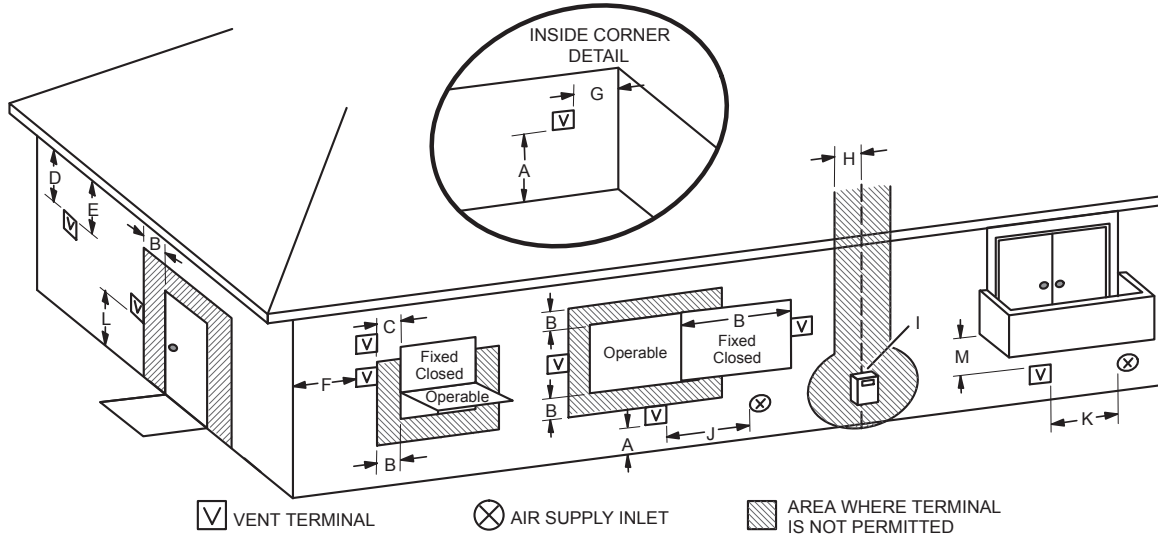

	US Installations ¹	Canadian Installations ²
A = Clearance above grade, veranda, porch, deck or balcony	12 inches (305mm) or 12 in. 305mm) above average snow accumulation.	must conform to CSA B149.1-10, Sect. 8.14.
B = Clearance to window or door that may be opened	4 feet (1.2m) below or to side of opening; 1 foot (30cm) above opening	6 inches (15cm) for appliances <10,000 Btuh (3kw), 12 inches (30cm) for appliances >10,000 Btuh (3kw), and <100,000 Btuh (30kw), 36 inches (.9m) for appliances > 100,000 Btuh (30kw)
C = Clearance to permanently closed window	* 12" (30cm)	* 12" (30cm)
D = Vertical clearance to ventilated soffit located above the terminal within a horizontal distance of 2 feet (0.6m) from the center line of the terminal	* Equal to or greater than soffit depth	* 3" (0.9m)
E = Clearance to unventilated soffit	* Equal to or greater than soffit depth	* 2" (0.6m)
F = Clearance to outside corner	* No minimum to outside corner	* No minimum to outside corner
G = Clearance to inside corner	* 3 ft. (.9m), 10 ft. (3.05 m) preferred	* 3 ft. (.9m), 10 ft. (3.05 m) preferred
H = Clearance to each side of center line extended above meter / regulator assembly	3 feet (.9m) within a height 15 feet (4.5m) above the meter / regulator assembly	3 feet (.9m) within a height 15 feet (4.5m) above the meter / regulator assembly
I = Clearance to service regulator vent outlet	3 feet (.9m)*	*3 feet (.9m)
J = Clearance to non-mechanical air supply inlet to building or the combustion air inlet to any other appliance	4 feet (1.2m) below or to side of opening; 1 foot (30cm) above opening	6 inches (15cm) for appliances <10,000Btuh (3kw), 12 inches (30cm) for appliances > 10,000 Btuh (3kw) and <100,000 Btuh (30kw), 36 inches (.9m)for appliances > 100,000 Btuh (30kw)
K = Clearance to mechanical air supply inlet	3 feet (.9m) above if within 10 feet (3m) horizontally	6 feet (1.8m)
L = Clearance above paved sidewalk or paved driveway located on public property	* 7 feet (2.1m)	7 feet (2.1m)†
M = Clearance under veranda, porch, deck or balcony	*12 inches (305mm)‡	12 inches (30cm) ‡

¹ In accordance with the current ANSI Z223.1/NFPA 54 Natural Fuel Gas Code

² In accordance with the current CSA B149.1, Natural Gas and Propane Installation Code

† A vent shall not terminate less than 7 ft. (2.1m) above a paved sidewalk or paved driveway that is located on public property.

‡ Permitted only if veranda, porch, deck or balcony is full open on a minimum of two sides beneath the floor. We recommend avoiding this location if possible.

For clearances not specified in ANSI Z223.1/NFPA 54 or CSA B149.1, clearance will be in accordance with local installation codes and the requirements of the gas supplier and these installation instructions.

GENERAL VENTING REQUIREMENTS AND GUIDELINES

DIRECT VENT

▲ WARNING

ALL FURNACE INSTALLATIONS MUST COMPLY WITH THE NATIONAL FUEL GAS CODE OR, IN CANADA, CSA B149.1; NATURAL GAS AND PROPANE INSTALLATION CODE AND LOCAL CODES TO PROVIDE ADEQUATE COMBUSTION AND VENTILATION AIR FOR THE FURNACE. FAILURE TO DO SO CAN RESULT IN EXPLOSION, FIRE, PROPERTY DAMAGE, CARBON MONOXIDE POISONING, PERSONAL INJURY OR DEATH.

▲ WARNING

READ AND FOLLOW THE *GENERAL VENTING REQUIREMENTS AND GUIDELINES* OF THIS MANUAL FOR ADDITIONAL VENTING REQUIREMENTS PERTAINING TO ALL FURNACE INSTALLATIONS (INCLUDING DIRECT AND NON-DIRECT VENTING). FAILURE TO FOLLOW ALL INSTRUCTIONS IN THIS MANUAL CAN RESULT IN EQUIPMENT FAILURE, EQUIPMENT DAMAGE, PROPERTY DAMAGE, PERSONAL INJURY OR DEATH.

DIRECT-VENT (2-PIPE) INSTALLATIONS

The field-supplied vent system used for direct-vent installations uses 2 pipes; one inlet pipe for supplying the combustion air to the furnace, and an exhaust (or flue) pipe for transferring the flue products to the outside. The flue pipe is elevated at least 12 inches above the air intake pipe for all vertical installations to prevent flue gas recirculation during operation.

The furnace combustion air inlet must be located a minimum safe distance from the vent of any other gas or fuel-burning appliance or clothes dryer to prevent recirculation of the flue gases into the furnace combustion air inlet. Reference National Fuel Gas Code current edition and in Canada CSA 149.1 current edition for minimum distances. The only exception to this requirement is the case of multiventing two or more furnaces, which is covered in the section on multiventing of these instructions.

Direct-Vent systems must be installed so that the vent and combustion air intake pipes terminate in the same atmospheric pressure zone.

OPTION 1: STANDARD VERTICAL DIRECT-VENT TERMINATION

Figure 23 below shows a standard vertical termination for direct venting installations. Maintain the dimensions specified in this drawing for vertical venting of direct-vent furnace installations. Specific details of the roof penetration can be found in *Figure 24*.

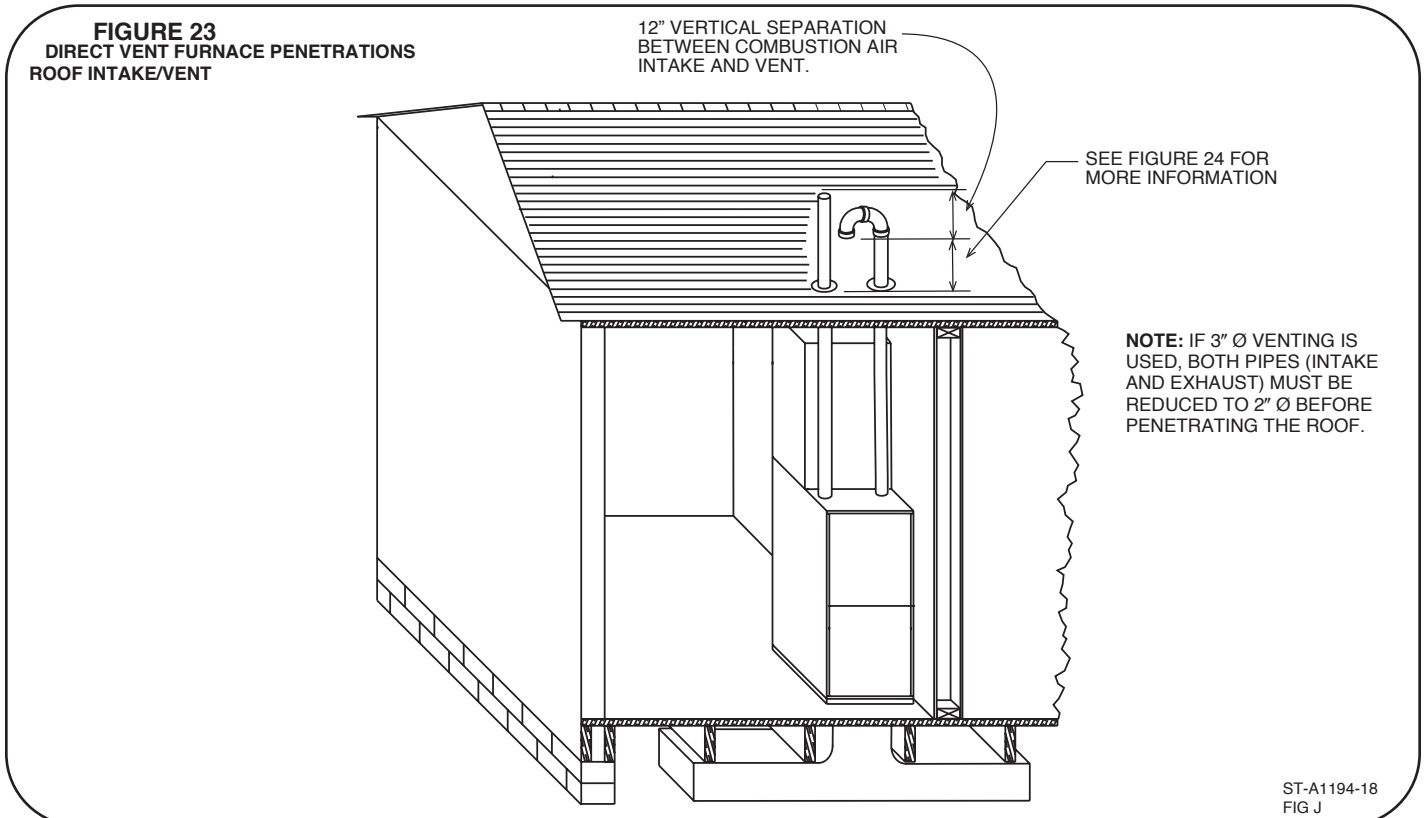

GENERAL VENTING REQUIREMENTS AND GUIDELINES

DIRECT VENT (cont.)

Figure 24 below shows the necessary detail for the roof penetration on a standard direct-vent vertical termination.

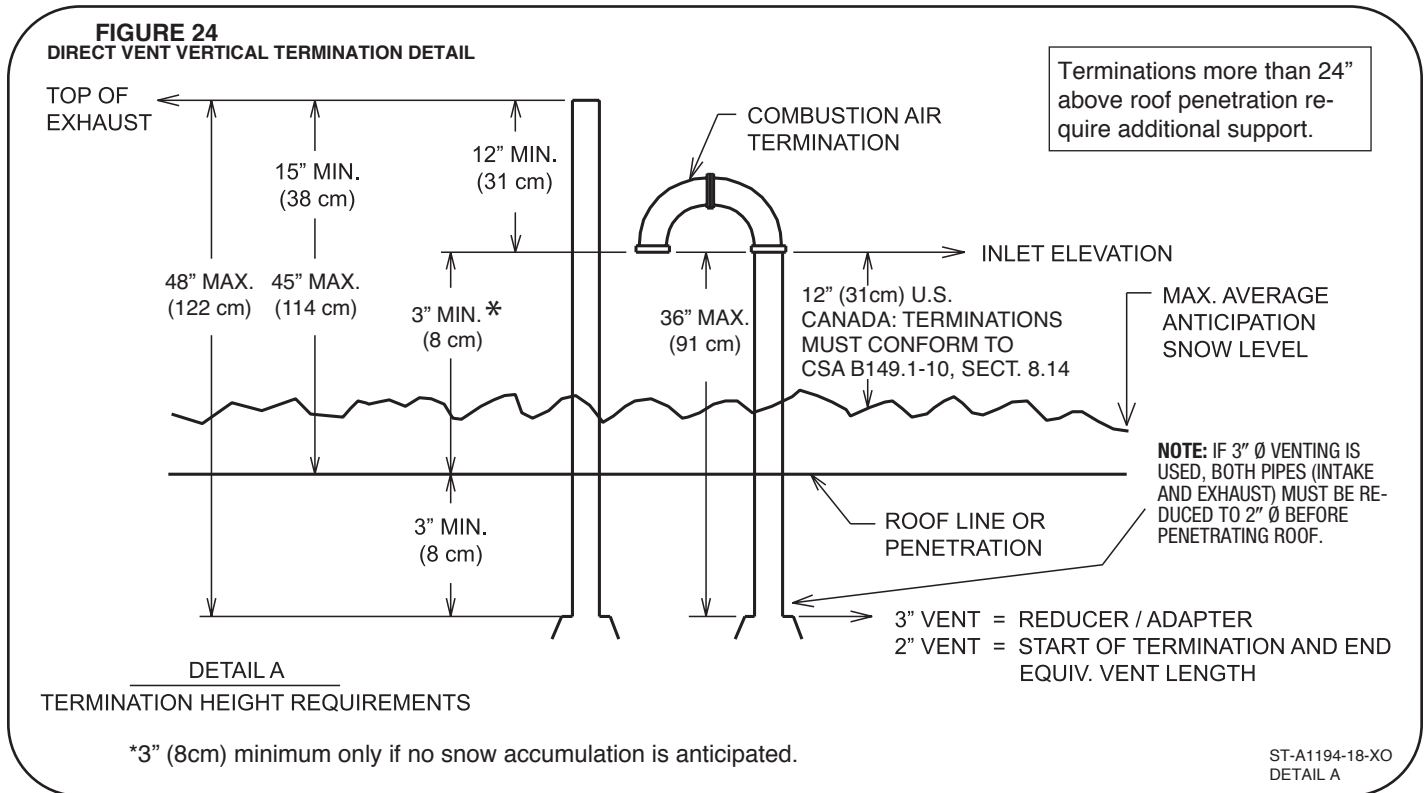

Venting

GENERAL VENTING REQUIREMENTS AND GUIDELINES

DIRECT VENT (cont.)

OPTION 2: STANDARD HORIZONTAL DIRECT-VENT TERMINATION

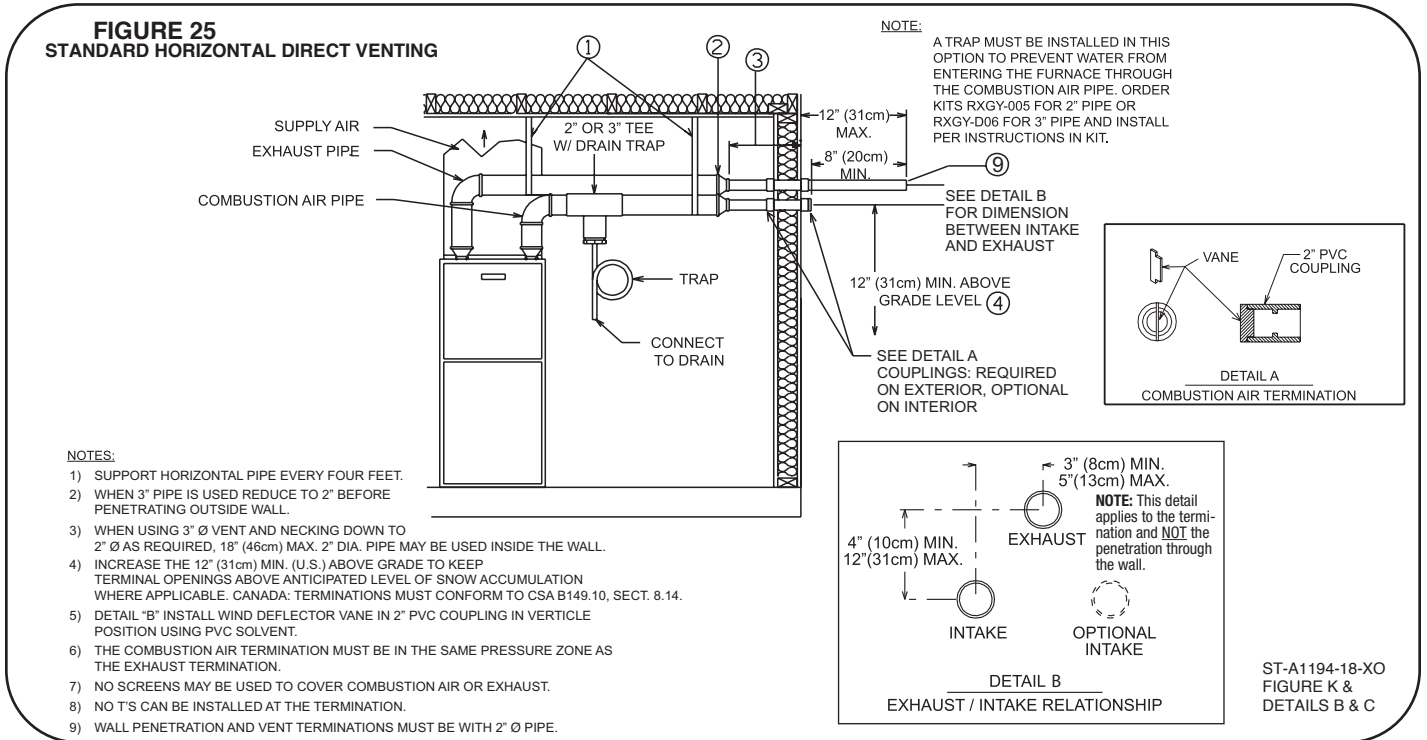

OPTION 3: VARIANT OF STANDARD HORIZONTAL DIRECT-VENT TERMINATION

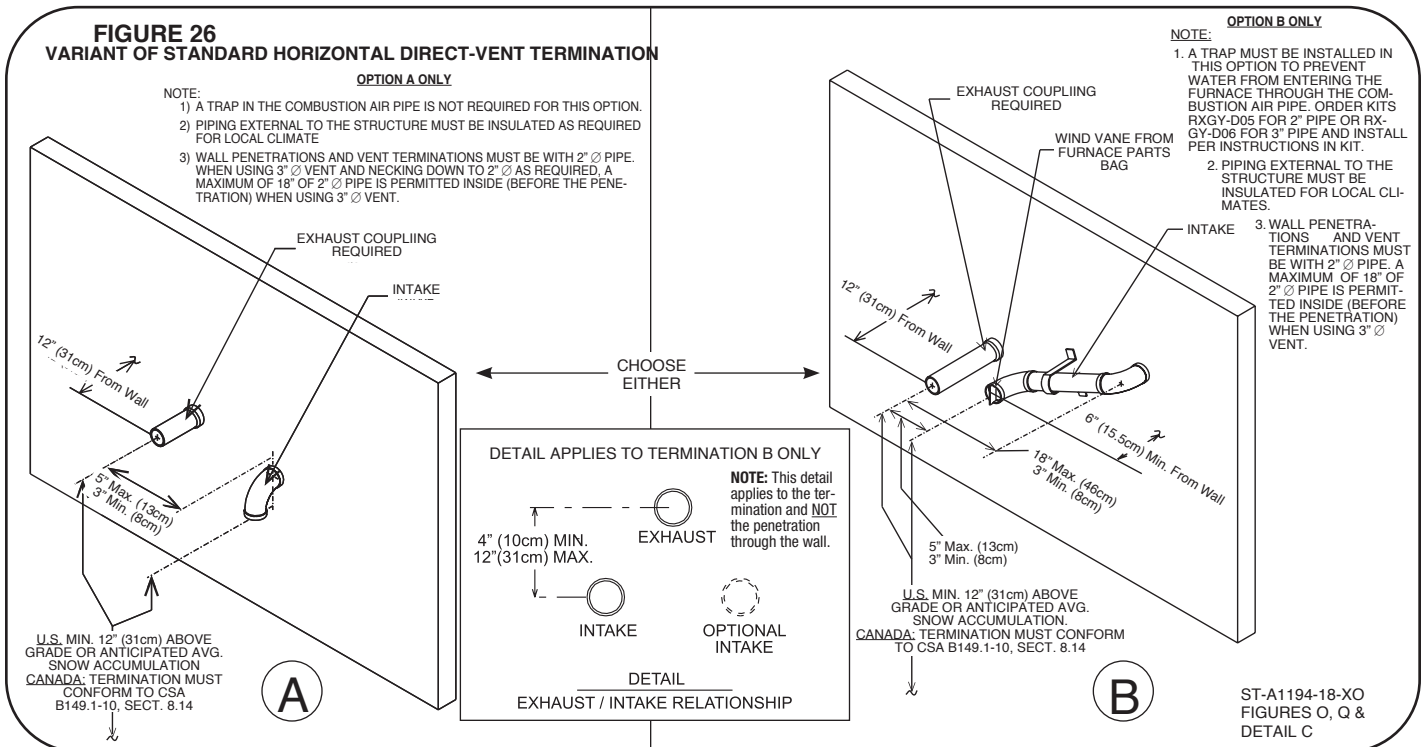

GENERAL VENTING REQUIREMENTS AND GUIDELINES

DIRECT VENT (cont.)

OPTION 4: ALTERNATE HORIZONTAL DIRECT-VENT TERMINATION

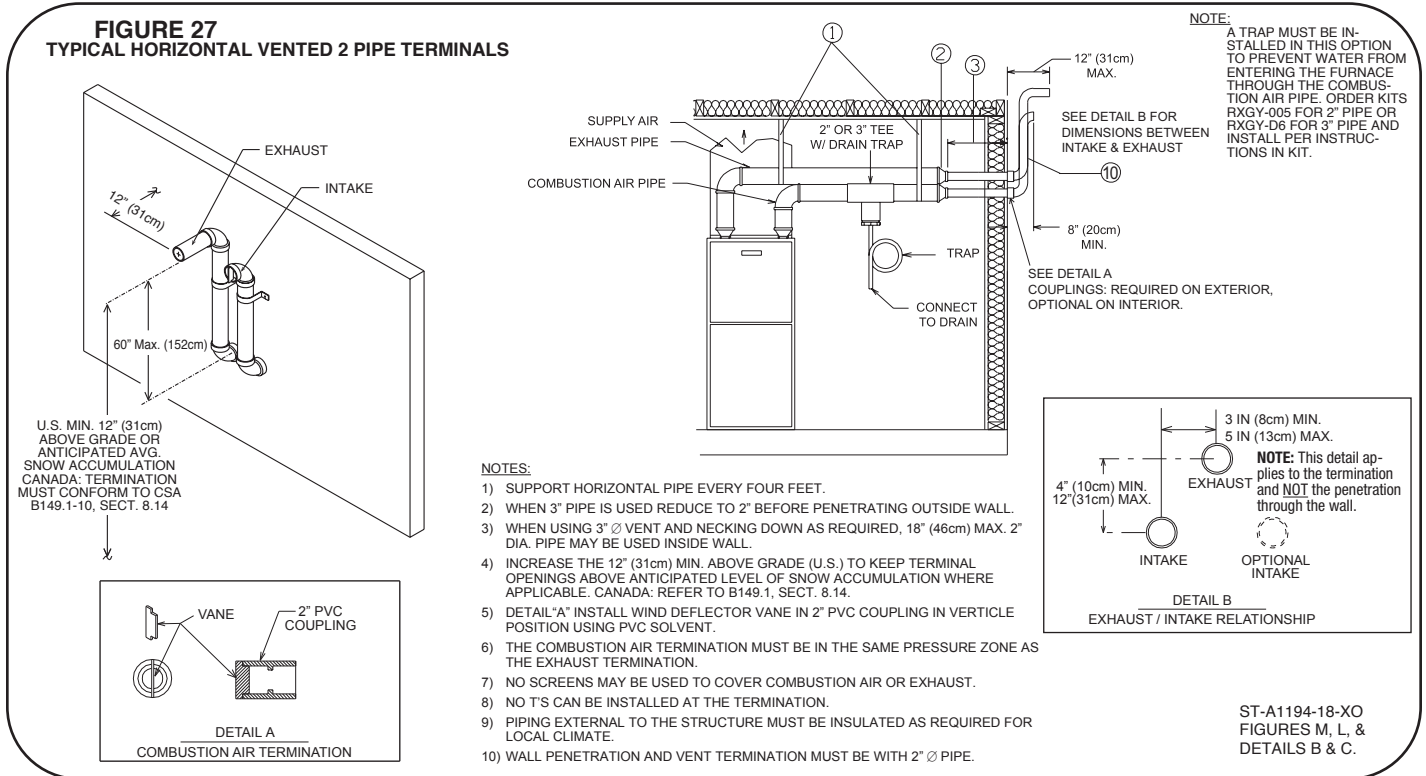

OPTION 5: VARIANT OF ALTERNATE HORIZONTAL DIRECT-VENT TERMINATION

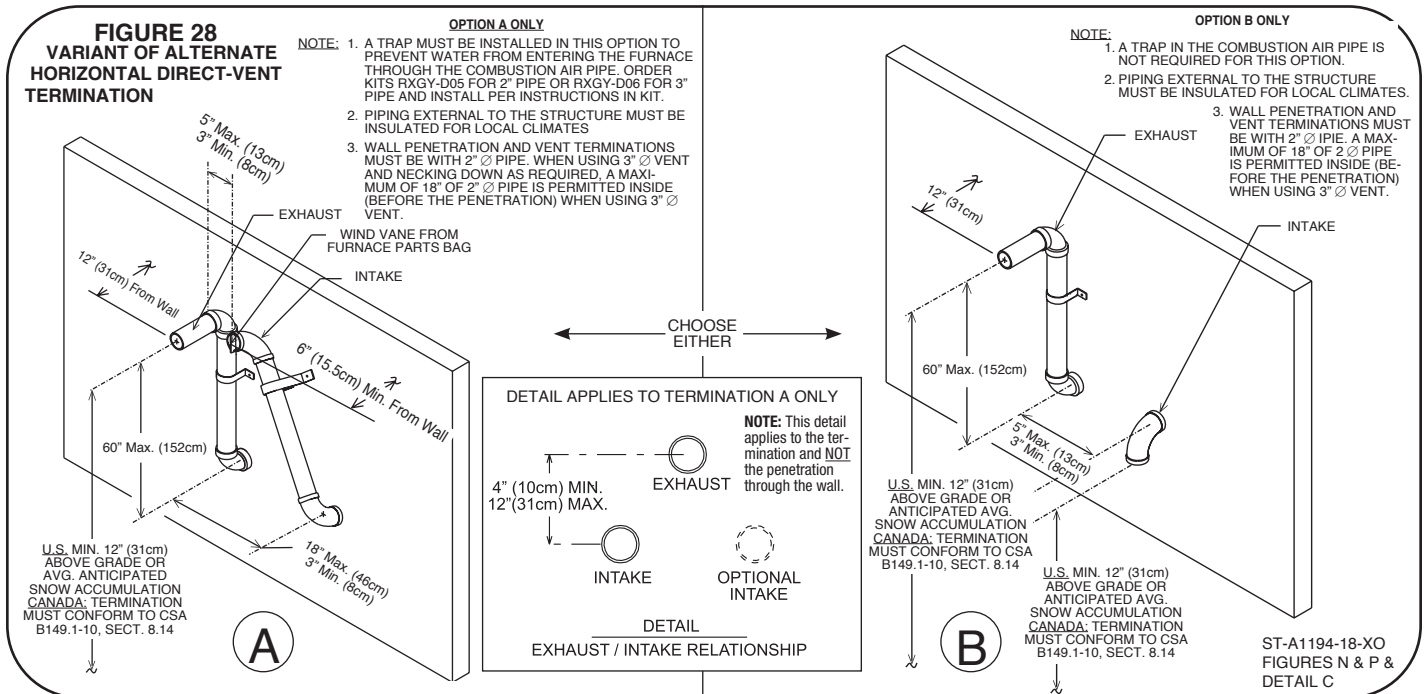

GENERAL VENTING REQUIREMENTS AND GUIDELINES

DIRECT VENT (cont.)

OPTIONAL TERMINATION ANGLES FOR OPTION FOR ALT. HORIZ. AND VARIANT OF ALT. HORIZ. DIRECT-VENT TERMINATIONS (OPTIONS 4 & 5)

NOTE: These optional termination angles apply only to direct-vent termination options 4 and 5 above (alternate horizontal and variant of optional horizontal) in this section. Do not use these angled terminations with any other termination option.

NOTE: This option is recommended for installations where the distance from the vent pipe perpendicular to another structure is less than 10 feet.

Top view for using 22° or 45° termination on a single furnace.

Using alternate vent terminations from options 4 or 5 above, simply rotate the final elbows 22 or 45 degrees from the wall as shown below.

1. Both the combustion air and exhaust final termination elbows must be at the same angle and face the same direction (left or right).
2. A wind vane must be installed in the combustion air inlet pipe as shown in the diagram.
3. Number and distance between (recommended) support straps must provide rigid support.

4. Mark the final (22° or 45°) angles on the top of the vertical risers and final elbows before gluing into place to ensure that the final angles are correct.
5. Insulating the exhaust termination vertical riser may be necessary in some areas, depending on the total length and expected temperatures in the area.
6. Do not angle (22° or 45°) into an inside corner.
7. Do not use screens on the inlet or exhaust pipes.
8. Angled terminations cannot be used on pairs of vents.
9. This termination may cause discoloration over time to the external surface of the structure.
10. Wall penetrations and vent terminations must be with 2" \varnothing pipe to reduce the possibility of ice forming at the termination. A maximum of 18" of 2" \varnothing pipe is permitted inside (before the penetration) when using 3" \varnothing vent.

FIGURE 29

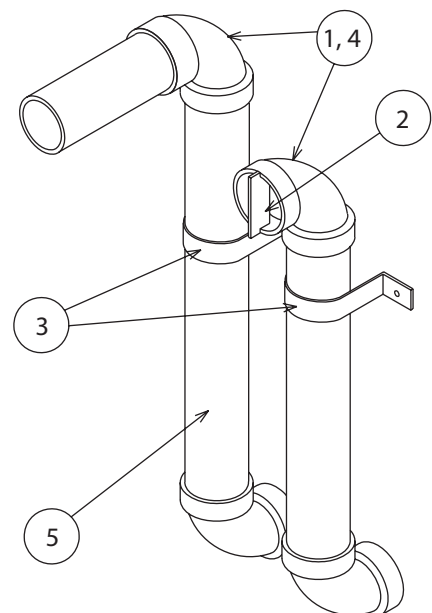
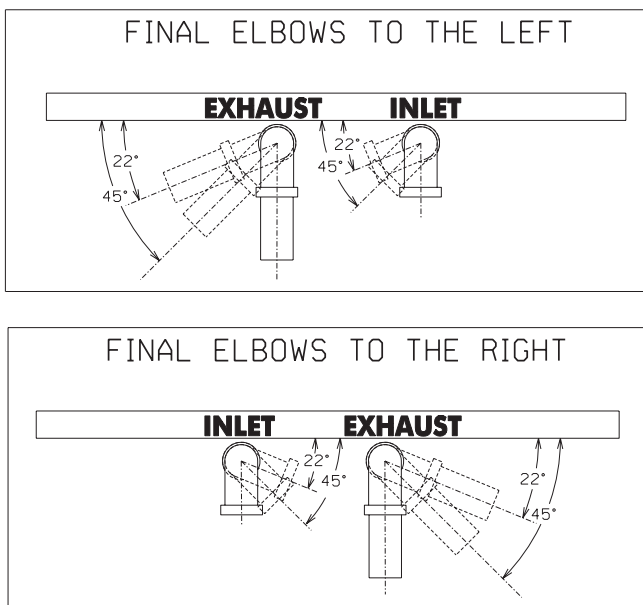

ST-A1194-20

GENERAL VENTING REQUIREMENTS AND GUIDELINES

DIRECT VENT (cont.)

OPTIONS 6 & 7: VERTICAL OR HORIZONTAL CONCENTRIC VENT TERMINATION
FOR 2" PIPE: RXGY-E02 (U.S. ONLY) OR RXGY-E02A (U.S. AND CANADA)
FOR 3" PIPE: RXGY-E03 (U.S. ONLY) OR RXGY-E03A (U.S. AND CANADA)

CONCENTRIC TERMINATIONS

These kits are for vertical/horizontal intake air/vent runs and may be installed through roofs or sidewalls. One 5 inch diameter hole (RXGY-E03 & RXGY-E03A) or 3-5/8 inch diameter hole (RXGY-E02 & RXGY-E02A) is required for the installation. See **Figure 30** for the general layout. Complete instructions are included with each kit.

NOTE: The following IPEX brand concentric vent termination (System 636) may be purchased in the field and used in place of the kits offered by the furnace manufacturer.

3" Concentric Vent Kit = Item #196006

NOTE: Maximum equivalent lengths specified in the **VENT PIPE SIZING AND MAXIMUM VENT LENGTHS** section of this manual are in addition to the concentric vent.

NOTE: With this option a trap on the inlet air pipe is NOT required.

Venting

FIGURE 30
CONCENTRIC VENT KIT NO. RXGY-E02A (2") AND RXGY-E03A (3")

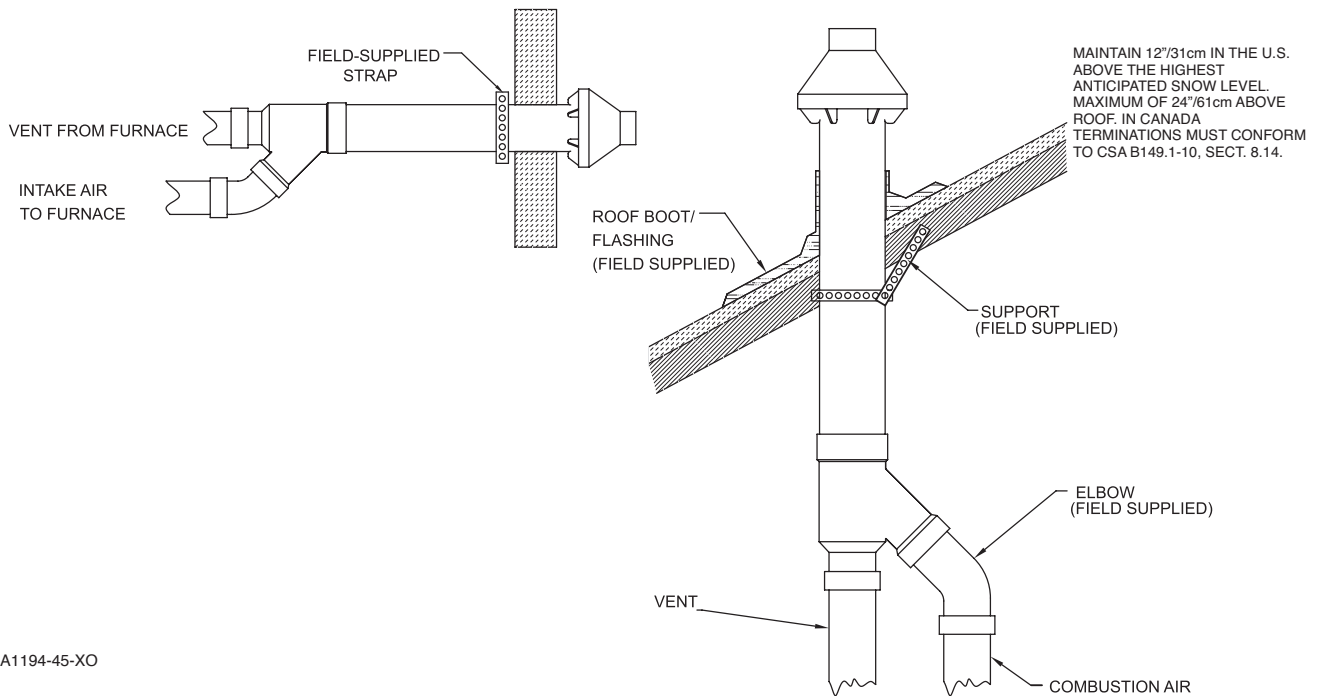

ST-A1194-45-XO

GENERAL VENTING REQUIREMENTS AND GUIDELINES

DIRECT VENT (cont.)

OPTIONS 8 & 9: 2" & 3" SIDE WALL VENT TERMINATIONS

FOR 2" PIPE: RXGY-G02

FOR 3" PIPE: RXGY-G01

This termination is for horizontal venting only. This termination may be installed with either a non-direct-vent or a direct-vent system. When installed as non-direct vent, only one wall penetration is necessary for the exhaust vent.

IMPORTANT: Do not install on the prevailing winter wind side of the structure.

IMPORTANT: Maintain a minimum of 12 inches (U.S.) above grade or the highest anticipated average snow level (whichever is greater) to the bottom of the vent cover or, in Canada, terminations must conform with CSA B149.1-10, Sect. 8.14, Canadian Natural Gas and Propane Installation Code.

NOTE: Dimensions between the inlet and outlet pipes (direct-vent only) are fixed by the sidewall termination. Other drawings in this manual which specify minimum and/or maximum distances (vertical and horizontal) between pipes do not apply to the sidewall termination kit.

NOTE: Multiventing – NO COMMON VENTING IS PERMITTED WITH THIS KIT.

NOTE: With this option a trap on the inlet combustion air pipe is NOT required.

NOTE: Install the vent and air intake piping into the vent plate openings. Seal all gaps between the pipes and wall. **BE SURE TO USE SILICONE SEALANT** to seal the vent pipe to the vent cap to permit field disassembly for annual inspection and cleaning. Also seal all pipe penetrations in the wall. **DO NOT INSTALL VENT KITS ONE ABOVE THE OTHER** to prevent the possibility of condensate freeze-up or recirculation.

NOTE: Vent should protrude a maximum of 2-1/4 inches beyond the vent plate. Air intake should protrude a maximum of 1 inch beyond the vent plate.

NOTE: The RXGY-G02 termination can be used with 3" vent pipe. A maximum of 18" of 2" Ø pipe can be used before penetrating the wall.

Complete installation instructions are included with these kits.

Venting

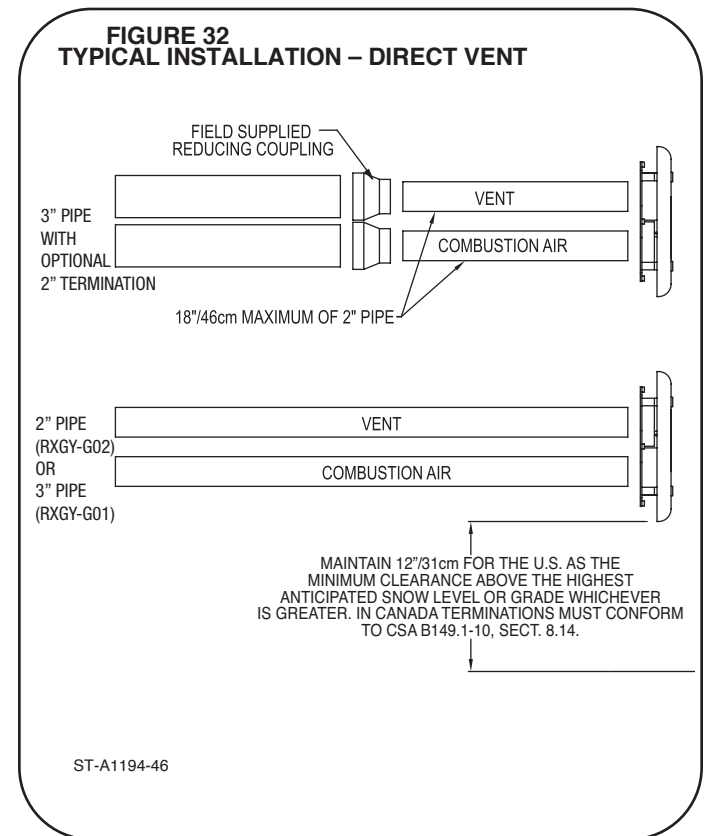
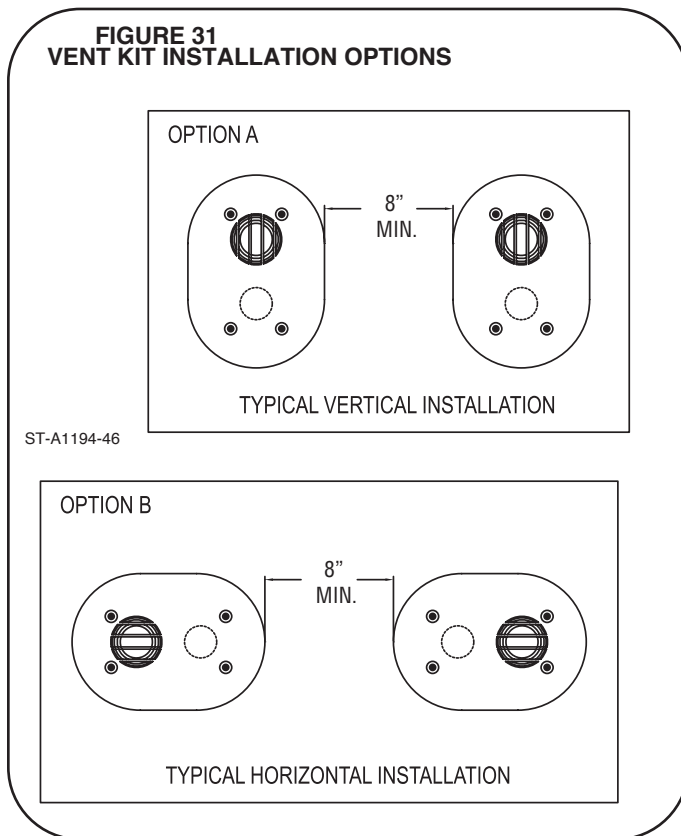

GENERAL VENTING REQUIREMENTS AND GUIDELINES

DIRECT VENT TERMINATION CLEARANCES

Figure 33 shows minimum clearances that must be used for direct venting terminations.

FIGURE 33
DIRECT VENT TERMINAL CLEARANCES

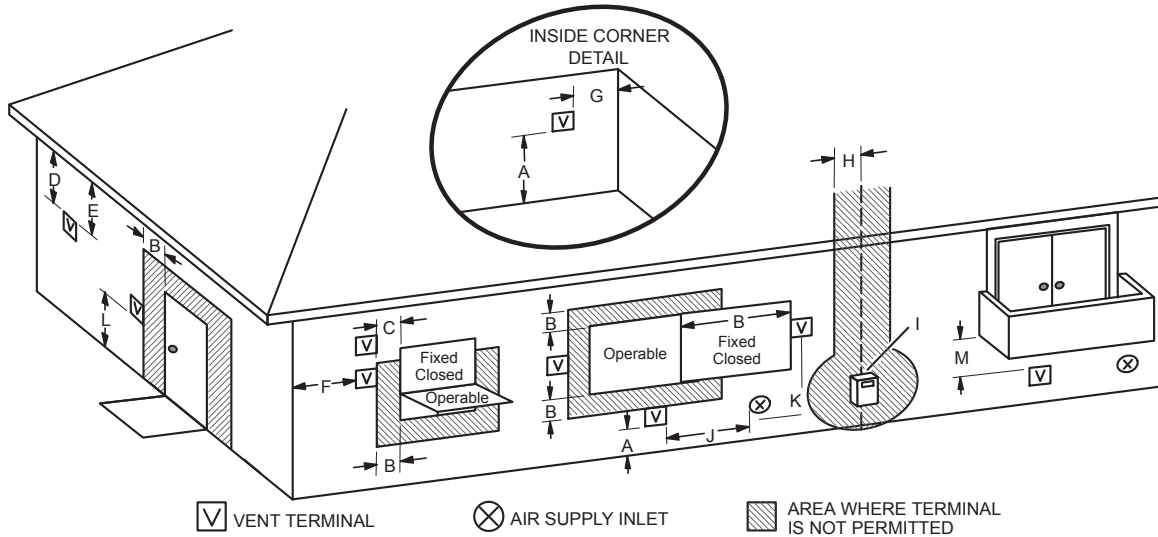

	US Installations ¹	Canadian Installations ²
A = Clearance above grade, veranda, porch, deck or balcony	12 inches (305mm) or 12 in. 305mm above average snow accumulation.	Must conform to CSA B149.1-10, Sect. 8.14.
B = Clearance to window or door that may be opened	6 inches (152mm) for appliances <10,000 Btuh (3kw), 9 inches (305mm) for appliances >10,000 Btuh (3kw), and <50,000 Btuh (15kw), 12 inches (.9m) for appliances > 50,000 Btuh (15kw)	6 inches (15cm) for appliances <10,000 Btuh (3kw), 12 inches (305mm) for appliances >10,000 Btuh (3kw), and <100,000 Btuh (30kw), 36 inches (.9m) for appliances > 100,000 Btuh (30kw)
C = Clearance to permanently closed window	* 12" (30cm)	* 12" (30cm)
D = Vertical clearance to ventilated soffit located above the terminal within a horizontal distance of 2 feet (0.6m) from the center line of the terminal	* Equal to or greater than soffit depth	* 3 ft. (0.9m)
E = Clearance to unventilated soffit	* Equal to or greater than soffit depth	* 2 ft. (0.6m)
F = Clearance to outside corner	* No minimum to outside corner	* No minimum to outside corner
G = Clearance to inside corner	* 3 ft. (.9m), 10 ft. (3.05 m) preferred	* 3 ft. (.9m), 10 ft. (3.05m) preferred
H = Clearance to each side of center line extended above meter / regulator assembly	3 feet (.9m) within a height 15 feet (4.5m) above the meter / regulator assembly	3 feet (.9m) within a height 15 feet (4.5m) above the meter / regulator assembly
I = Clearance to service regulator vent outlet	3 feet (.9m)*	*3 feet (.9m)
J = Clearance to non-mechanical air supply inlet to building or the combustion air inlet to any other appliance	6 inches (152mm) for appliances <10,000Btuh (3kw), 9 inches (305mm) for appliances > 10,000 Btuh (3kw) and <50,000 Btuh (15kw), 12 inches (.9m) for appliances > 50,000 Btuh (15kw)	6 inches (15cm) for appliances <10,000Btuh (3kw), 12 inches (30cm) for appliances > 10,000 Btuh (3kw) and <100,000 Btuh (30kw), 36 inches (.9m) for appliances > 100,000 Btuh (30kw)
K = Clearance to mechanical air supply inlet	3 feet (.9m) above if within 10 feet (3m) horizontally	6 feet (1.8m)
L = Clearance above paved sidewalk or paved driveway located on public property	* 7 feet (2.1m)	7 feet (2.1m)†
M = Clearance under veranda, porch, deck or balcony	*12 inches (305mm)‡	12 inches (30cm) ‡

¹ In accordance with the current ANSI Z223.1/NFPA 54 Natural Fuel Gas Code

² In accordance with the current CSA B149.1, Natural Gas and Propane Installation Code

† Vent shall not terminate less than 7 ft. (2.1m) above a paved sidewalk or paved driveway that is located on public property.

‡ Permitted only if veranda, porch, deck or balcony is full open on a minimum of two sides beneath the floor. We recommend avoiding this location if possible.

*For clearances not specified in ANSI Z223.1/NFPA 54 or CSA B149.1, clearance will be in accordance with local installation codes and the requirements of the gas supplier and these installation instructions."

GENERAL VENTING REQUIREMENTS AND GUIDELINES

MULTIVENTING OF DIRECT-VENT FURNACES

Figures 34 & 35: NOTE: WHEN VENTING MULTIPLE FURNACES IN CLOSE PROXIMITY, EACH FURNACE MUST BE INDIVIDUALLY VENTED – NO COMMON VENTING IS PERMITTED. See **Figures 34 & 35** for positioning of the terminations. When more than two furnaces are to be vented, there must be at least 3 feet between the first two furnaces and the third and etc. **Figure 34, (Detail A)** below shows the necessary detail for the roof penetration on a standard direct-vent vertical termination.

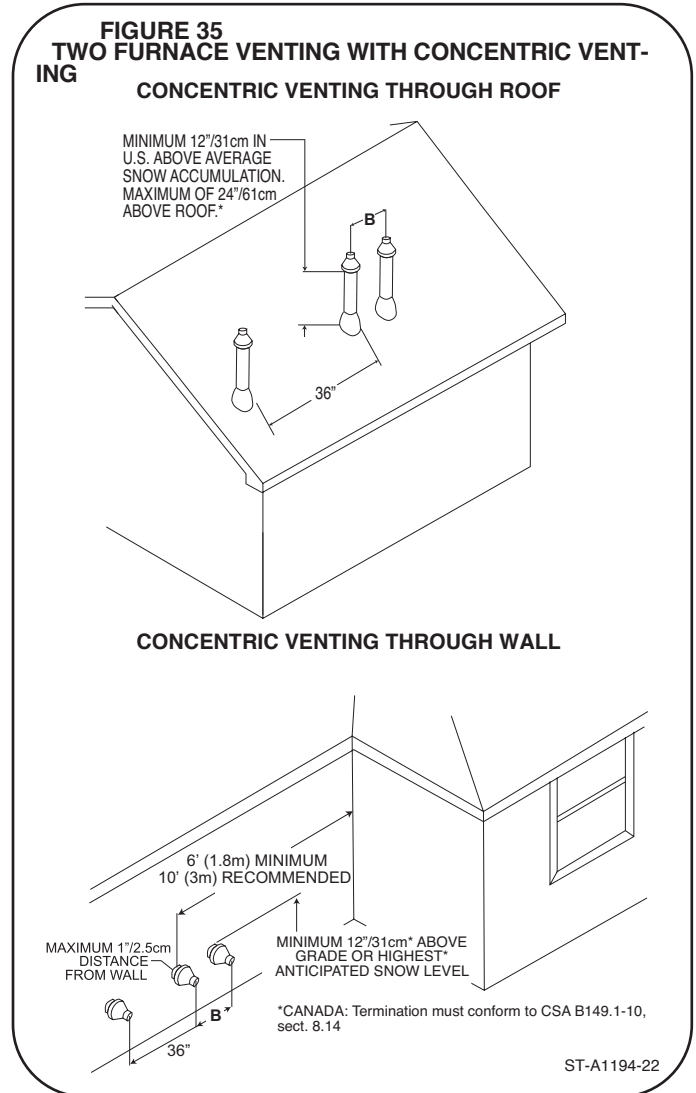
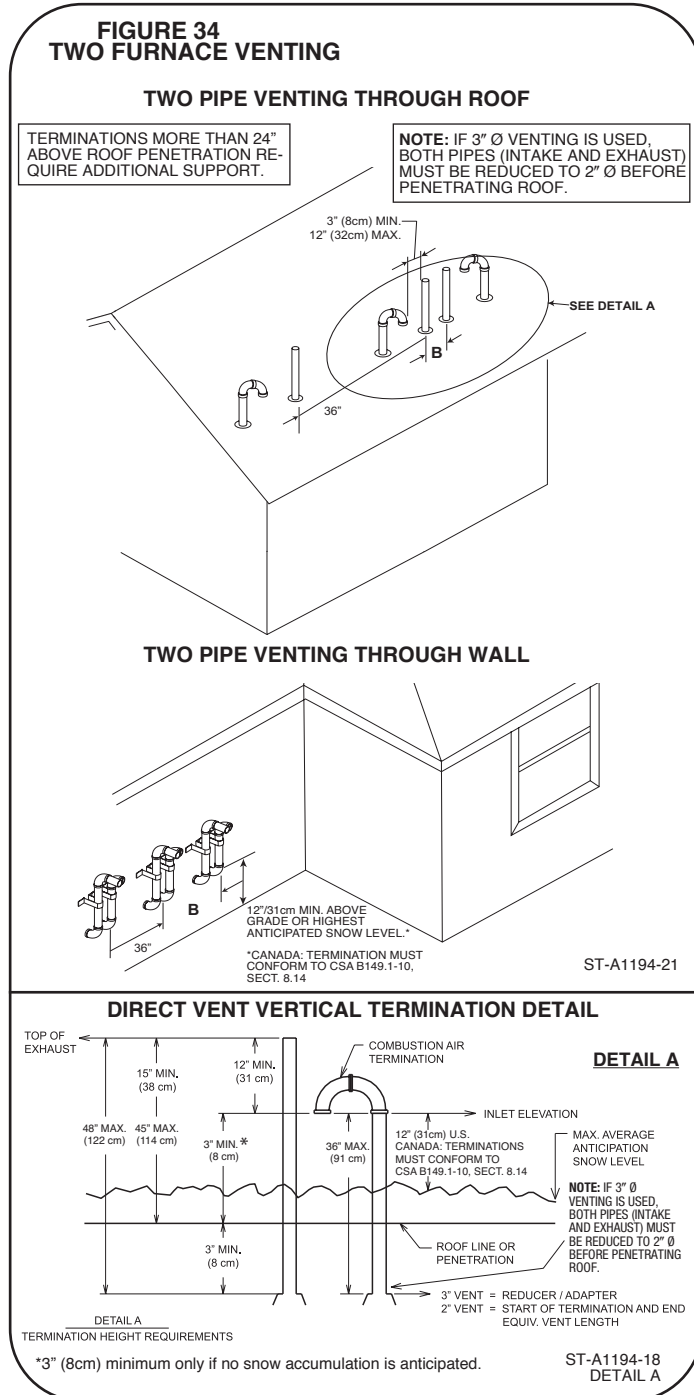

For 2 Direct Vent Furnace Installations

- B 1.** Terminations must be 9'-24" apart.
- 2.** Canada: 12" (300mm) for inputs 10k Btuh (3kW) up to and including 100K Btuh (30kW)
36" (900mm) for inputs exceeding 100K Btuh (30kW)

For 3 or More Direct Vent Furnace Installations

Furnace terminations require 36" between each additional pair of terminations for US and Canada.

CONDENSATE DRAIN

CONDENSATE DRAIN & DRAIN NEUTRALIZER

GENERAL INFORMATION

CAUTION

DO NOT RUN DRAIN OUTDOORS. FREEZING OF CONDENSATE CAN CAUSE PROPERTY DAMAGE.

IMPORTANT: Do not connect into a common drain line with an air conditioner evaporator coil drain located below the furnace. A blocked or restricted drain line can result in overflow of the coil pan and negate the furnace blocked drain shutoff control.

The condensate drain trap is self-priming. Upon the first heat attempt after installation or the first ignition after a long off period (e.g. summer), the trap will be dry allowing air to pull through the trap and causing the condensate to be held in the collector box by the negative pressure while the inducer is energized.

Condensate builds up in the collector box until the level reaches the electronic water level sensor. When this happens the heat attempt is ended thus shutting off the inducer after a post purge. This relieves the negative pressure pulled through the trap and the water then falls into the trap generally priming it after the first time. Note that in some circumstances this process may be repeated up to four times before the trap is fully primed – particularly in horizontal installations where there is less volume of water in the collector box below the water level sensor.

Important: There are two options when choosing a height for the condensate vent riser (also see Figure 36):

A. **CONDENSATE OVERFLOW** – When the top of the vent tube is below the elevation of the LOWER condensate water level sensor (aka electronic water level sensor) the furnace will continue to run even if the drain is blocked. A blocked drain will cause the condensate water to overflow the vent and spill water on the floor below it but the furnace will continue to run and heat will be provided. If the installer uses this approach, he must make sure that there is a mechanism for handling the possibility of water overflow onto the floor in the event of a blocked drain.

B. **FURNACE SHUTOFF** – When the top of the vent tube is above the elevation of the LOWER condensate water level sensor (aka electronic water level sensor), the furnace will be shut off in the event of a blocked drain and no heat will be provided.

NOTE: IT IS IMPORTANT ANY TIME THE FURNACE IS INSTALLED IN AN ENVIRONMENT WHERE THE TEMPERATURE CAN GET BELOW FREEZING THAT THE TRAP AND ALL CONDENSATE LINE BE PROTECTED FROM FREEZING. IF THE FURNACE IS EXPOSED TO TEMPERATURES BELOW FREEZING, THE TRAP WILL FREEZE AND THIS WILL CAUSE THE FURNACE TO SHUT DOWN AND/OR DAMAGE THE DRAIN TRAP UNLESS FREEZE PROTECTION IS INSTALLED.

If local codes require, install a condensate neutralizer cartridge in the drain line. Install cartridge in horizontal position only. Also install an overflow line if routing to a floor drain. See Figure 36.

If no floor drain is available, install a condensate pump that is resistant to acidic water. Pumps are available from your local distributor. If pump used is not resistant to acidic water, a condensate neutralizer must be used ahead of the pump. The condensate pump must have an auxiliary safety switch to prevent operation of the furnace and resulting overflow of condensate in the event of pump failure. The safety switch must be wired through the “R” circuit only (low voltage) to provide operation in either heating or cooling modes.

For Econet-enabled systems, the condensate overflow switch can be connected to the auxiliary inputs on the furnace control – see section titled “Auxiliary Inputs” in the furnace control section.

CONDENSATE DRAIN

CONDENSATE DRAIN & DRAIN NEUTRALIZER (cont.)

CONDENSATE DRAIN LOCATING INSTRUCTIONS

FIGURE 36

NOTE: THESE IMAGES INTENTIONALLY DEPICT GENERIC VIEWS OF THE DRAIN ROUTING. THE INSTALLER HAS THE OPTION TO ROUTE THE DRAIN TO THE RIGHT OR LEFT SIDE OF THE FURNACE AS NEEDED.

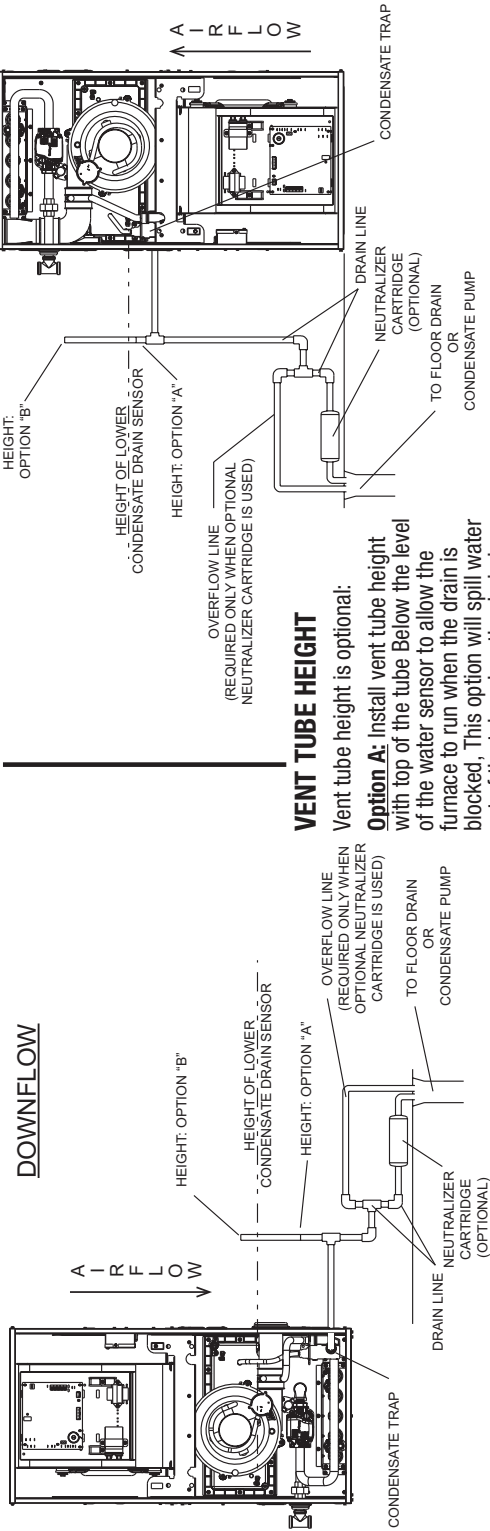

VENT TUBE HEIGHT

Vent tube height is optional.

Option A: Install vent tube height with top of the tube Below the level of the water sensor to allow the furnace to run when the drain is blocked. This option will spill water out of the tube when the drain is blocked, but the furnace will continue to run.

Option B: Install vent tube height with top of the tube Above the level of the lower condensate water sensor to shut the furnace down when the drain is blocked. This option will not spill water from the drain vent but the furnace will also not continue to run with a blocked drain.

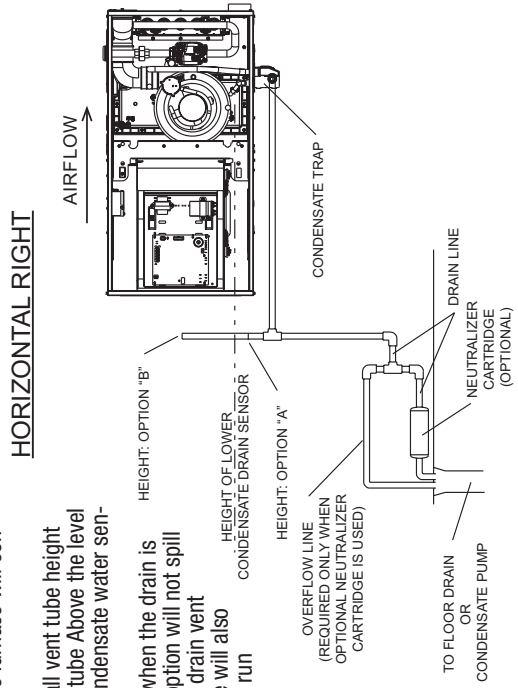

HORIZONTAL RIGHT

HORIZONTAL LEFT

ST-A1194-42-X0

Condensate Drain

GAS SUPPLY

GAS SUPPLY AND PIPING

IMPORTANT SAFETY INFORMATION

NATURAL GAS AND PROPANE (LIQUEFIED PETROLEUM GAS / LPG) SAFETY

GAS SUPPLY

WARNING

- FURNACES USING PROPANE GAS ARE DIFFERENT FROM NATURAL GAS MODELS. A NATURAL GAS HEATER WILL NOT FUNCTION SAFELY ON PROPANE AND VICE VERSA. CONVERSIONS OF HEATER GAS TYPE SHOULD ONLY BE MADE BY QUALIFIED INSTALLERS USING FACTORY SUPPLIED COMPONENTS. THE FURNACE SHOULD ONLY USE THE FUEL TYPE IN ACCORDANCE WITH LISTING ON RATING PLATE. ANY OTHER FUEL USAGE WILL RESULT IN DEATH OR SERIOUS PERSONAL INJURY FROM FIRE AND/OR EXPLOSION.
- BOTH NATURAL GAS AND PROPANE HAVE AN ODORANT ADDED TO AID IN DETECTING A GAS LEAK. SOME PEOPLE MAY NOT PHYSICALLY BE ABLE TO SMELL OR RECOGNIZE THIS ODORANT. IF YOU ARE UNSURE OR UNFAMILIAR WITH THE SMELL OF NATURAL GAS OR PROPANE, ASK YOUR LOCAL GAS SUPPLIER. OTHER CONDITIONS, SUCH AS "ODORANT FADE," WHICH CAUSES THE ODORANT TO DIMINISH IN INTENSITY, CAN ALSO HIDE, CAMOUFLAGE, OR OTHERWISE MAKE DETECTING A GAS LEAK BY SMELL MORE DIFFICULT.
- UL OR CSA RECOGNIZED FUEL GAS DETECTORS ARE RECOMMENDED IN ALL ENCLOSED PROPANE AND NATURAL GAS APPLICATIONS WHEREIN THERE IS A POTENTIAL FOR AN EXPLOSIVE MIXTURE OF FUEL GAS TO ACCUMULATE. FUEL DETECTOR INSTALLATION SHOULD BE IN ACCORDANCE WITH THE DETECTOR MANUFACTURER'S RECOMMENDATIONS AND/OR LOCAL LAWS, RULES, REGULATIONS, OR CUSTOMS.
- BEFORE ATTEMPTING TO LIGHT THE FURNACE, MAKE SURE TO LOOK AND SMELL FOR GAS LEAKS. USE A SOAPY SOLUTION TO CHECK ALL GAS FITTINGS AND CONNECTIONS.

BUBBLING AT A CONNECTION INDICATES A LEAK THAT MUST BE CORRECTED. WHEN SMELLING TO DETECT A GAS LEAK, BE SURE TO ALSO SNIFF NEAR THE FLOOR. PROPANE GAS IS HEAVIER THAN AIR AND TENDS TO COLLECT AT LOWER LEVELS MAKING IT MORE DIFFICULT TO SMELL AT NOSE LEVEL. NATURAL GAS IS LIGHTER THAN

(Continued on next column)

AIR AND WILL RISE, POSSIBLY ACCUMULATING IN HIGHER PORTIONS OF THE STRUCTURE.

- IF A GAS LEAK IS PRESENT OR SUSPECTED:
 - DO NOT ATTEMPT TO FIND THE CAUSE YOURSELF.
 - NEVER USE AN OPEN FLAME TO TEST FOR GAS LEAKS. THE GAS CAN IGNITE RESULTING IN DEATH, PERSONAL INJURY, OR PROPERTY DAMAGE.
 - DO NOT TRY TO LIGHT ANY APPLIANCE.
 - DO NOT TOUCH AND ELECTRICAL SWITCH.
 - DO NOT USE ANY PHONE IN YOUR BUILDING.
 - LEAVE THE BUILDING IMMEDIATELY AND CALL THE GAS SUPPLIER FROM A NEIGHBOR'S PHONE. FOLLOW THE GAS SUPPLIER'S INSTRUCTIONS.
 - IF YOU CANNOT REACH YOUR GAS SUPPLIER, CALL THE FIRE DEPARTMENT.
 - DO NOT RETURN TO THE BUILDING UNTIL AUTHORIZED BY THE GAS SUPPLIER OR FIRE DEPARTMENT.
- SHOULD OVERHEATING OCCUR OR THE GAS SUPPLY FAIL TO SHUT OFF, TURN OFF THE MANUAL GAS CONTROL VALVE TO THE FURNACE.
- CONSULT WITH THE LOCAL BUILDING DEPARTMENT AND FUEL GAS SUPPLIER BEFORE INSTALLING THE HEATER:
 - THE INSTALLATION AND PURGING OF GAS PIPING MUST CONFORM TO LOCAL CODES, UTILITY COMPANY REQUIREMENTS, AND THE LATEST EDITION OF NATIONAL FUEL GAS CODE (NFGC) - ANSI Z223.1/NFPA 54, OR CSA B149.1, NATURAL GAS AND PROPANE INSTALLATION CODE.
 - LP FURNACES SHOULD NOT BE INSTALLED BELOW GRADE (IN A BASEMENT FOR EXAMPLE) IF SUCH INSTALLATION IS PROHIBITED BY FEDERAL, STATE, PROVINCIAL, AND/OR LOCAL LAWS, RULES, REGULATIONS, OR CUSTOMS.
 - INSTALLATION OF A GAS PRESSURE REGULATOR MAY BE REQUIRED IN THE GAS SUPPLY LINE. THE REGULATOR SHOULD NOT EXCEED THE MAXIMUM SUPPLY PRESSURE LISTED ON THE FURNACE RATING PLATE. DO NOT USE AN INDUSTRIAL-TYPE GAS REGULATOR.
 - FOLLOW ALL LOCAL CODES AND SECTION 8.3 OF NFGC WITH REGARD TO PURGING OF GAS PIPING TO ENSURE THAT THE AIR AND/OR FUEL GAS IN THE GAS PIPING IS PROPERLY VENTED TO A LOCATION WHERE AN EXPLOSIVE MIXTURE CANNOT ACCUMULATE.

GAS PIPING

▲ WARNING

THIS FURNACE IS EQUIPPED AT THE FACTORY FOR USE ON NATURAL GAS ONLY. CONVERSION TO LP GAS REQUIRES A SPECIAL KIT IS AVAILABLE AT THE DISTRIBUTOR. FAILURE TO USE THE PROPER CONVERSION KIT CAN CAUSE FIRE, CARBON MONOXIDE POISONING, EXPLOSION, PROPERTY DAMAGE, PERSONAL INJURY OR DEATH. SEE THE CONVERSION KIT INDEX SUPPLIED WITH THE FURNACE. THIS INDEX IDENTIFIES THE PROPER LP GAS CONVERSION KIT REQUIRED FOR EACH PARTICULAR FURNACE.

IMPORTANT: Any additions, changes or conversions required for the furnace to satisfactorily meet the application should be made by a qualified installer, service agency or the gas supplier, using factory-specified or approved parts.

IMPORTANT: Connect this furnace only to gas supplied by a commercial utility or commercial fuel provider.

IMPORTANT: U.L. or CSA recognized fuel gas and carbon monoxide (CO) detector(s) are recommended in all applications, and their installation should be in accordance with the manufacturer's recommendations and/or local laws, rules, regulations or customs.

Install the gas piping according to all local codes and regulations of the utility company.

If possible, run a separate gas supply line directly from the meter to the furnace. Conventional and alternate gas installations are detailed in Figure 37. Alternate gas from right of cabinet will require additional fittings. Two street elbows are recommended to route gas line behind the valve and align the knockout in the furnace casing. Consult the local gas company for the location of the manual main shut-off valve. **The gas line and manual gas stop must be adequate in size to prevent undue pressure drop and never smaller than the pipe size to the gas valve on the furnace.** Refer to Table 12 for natural gas (Table 13 for LP gas) for the recommended gas pipe size. See Figure 37 for typical gas pipe connections.

Install a ground joint union within 3 feet of the cabinet to easily remove the gas valve assembly. Local codes may dictate the location of the ground joint union. Install a manual shut-off valve in the gas line outside of the furnace casing and upstream of the ground joint union. The manual shut-off valve should be readily accessible to turn the gas supply on or off. Install a drip leg in the gas supply line as close to the furnace as possible. Always use a pipe compound resistant to the action of liquefied petroleum gases on all threaded connections.

IMPORTANT: When making gas pipe connections, use a back-up wrench to prevent any twisting of the main gas valve and manifold. Do not overtighten gas valve on pipe.

FIGURE 37
GAS PIPING INSTALLATION

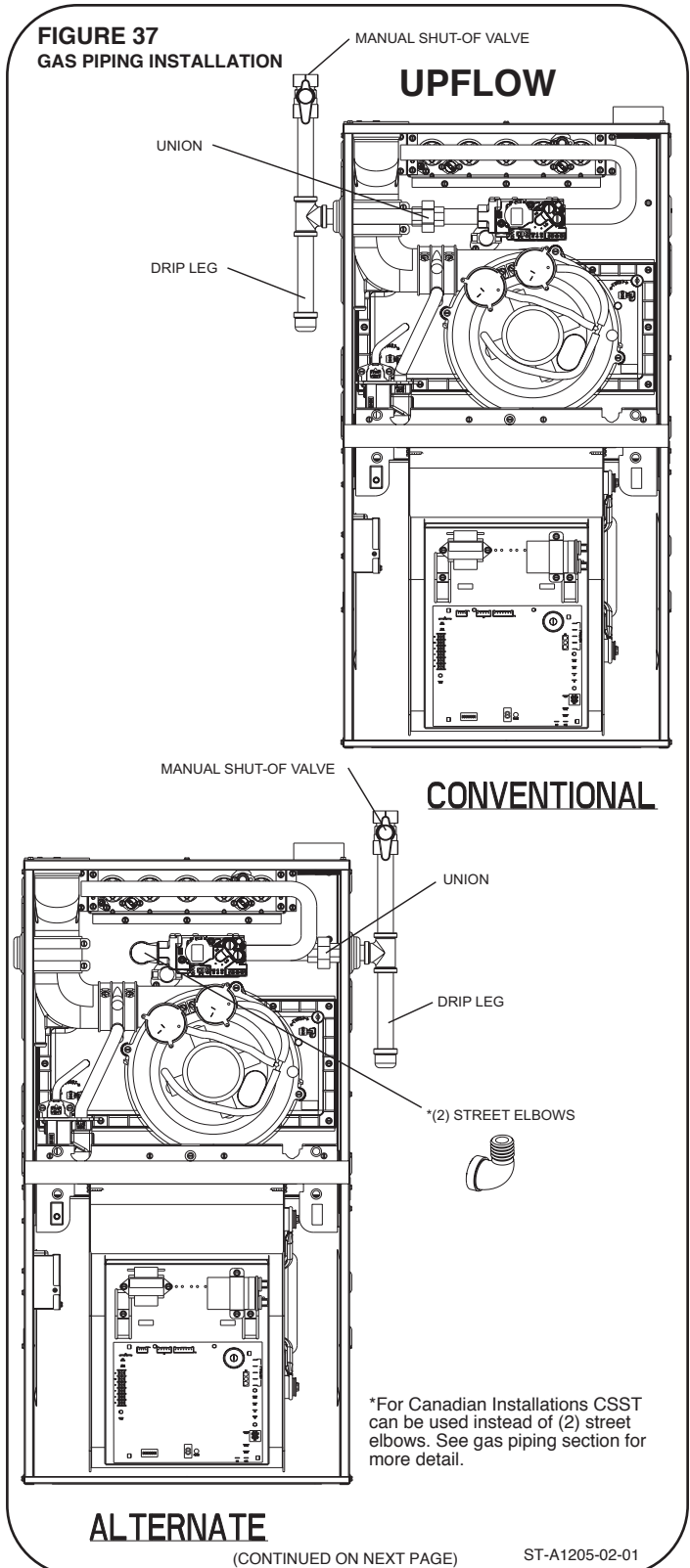

Gas Supply

(CONTINUED ON NEXT PAGE)

ST-A1205-02-01

GAS SUPPLY

GAS PIPING

FIGURE 37 – continued
GAS PIPING INSTALLATION

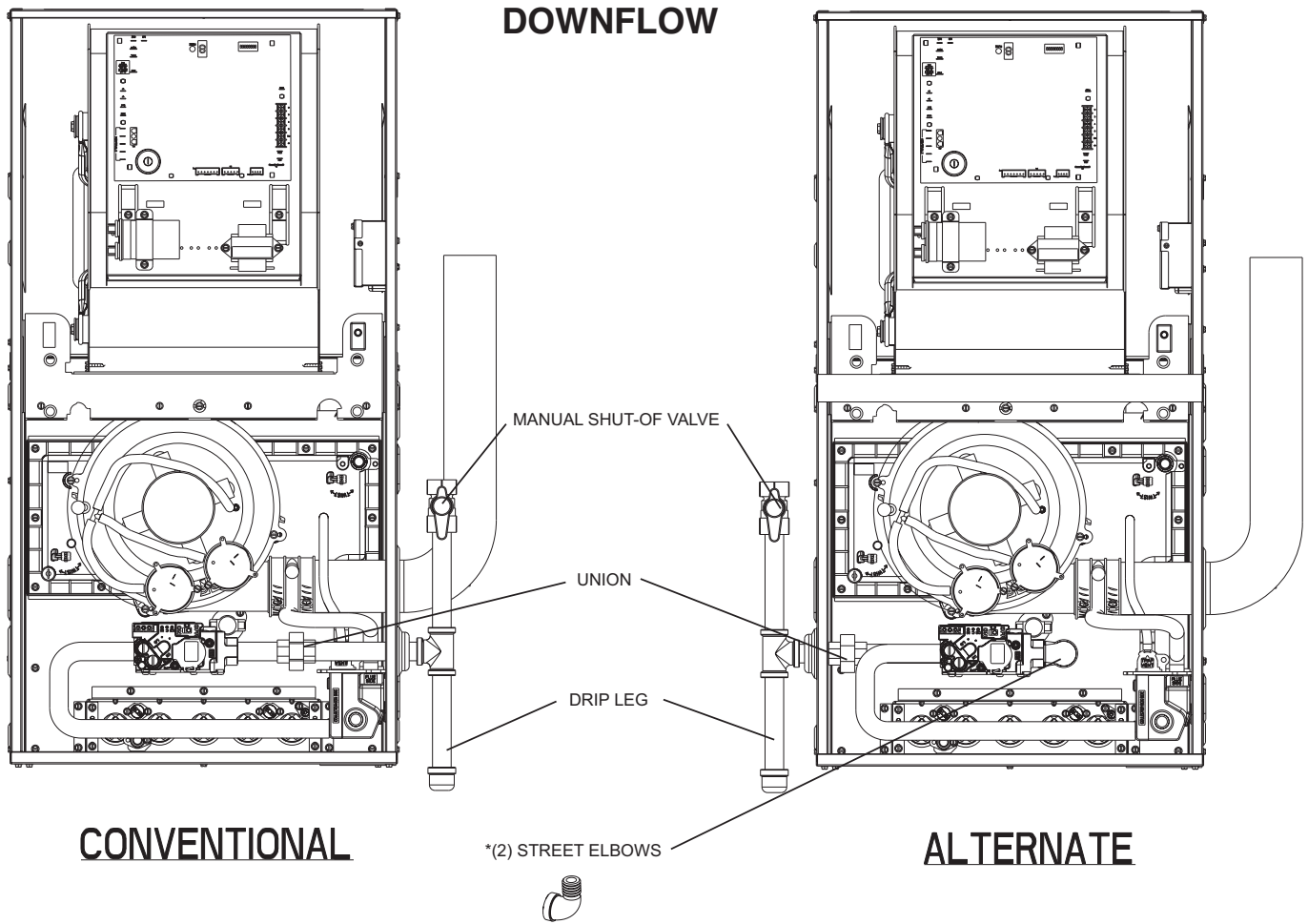

*For Canadian Installations CSST can be used instead of (2) street elbows.

(CONTINUED ON NEXT PAGE)

ST-A1205-03-01

GAS PIPING

FIGURE 37 – continued
GAS PIPING INSTALLATION

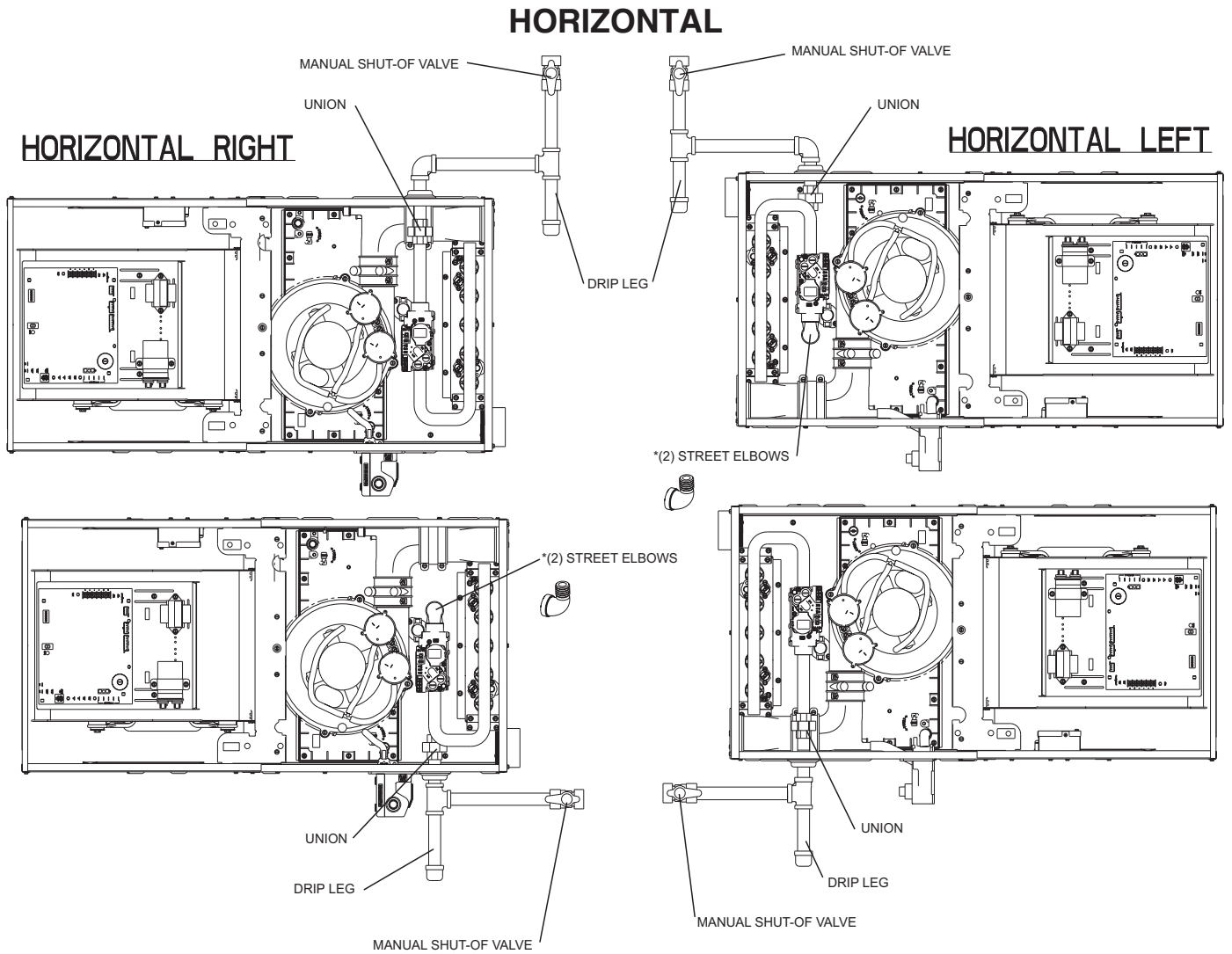

* FOR CANADIAN INSTALLATIONS CSST CAN BE USED INSTEAD OF (2) STREET ELBOWS.

ST-A1205-04-01

GAS SUPPLY

GAS PRESSURE

Any strains on the gas valve can change the position of the gas orifices in the burners. This can cause erratic furnace operation.

IMPORTANT: Do not run a flexible gas connector inside the furnace. The gas pipe gasket in the cabinet does not seal around a flexible gas line.

If local codes allow the use of a flexible gas appliance connector, always use a new listed connector. Do not use a connector which has previously serviced another gas appliance. Massachusetts law requires that all flexible connectors be less than 36".

It is important to have all openings in the cabinet burner compartment sealed for proper furnace operation.

IMPORTANT: ENSURE that the furnace gas valve is not to be subjected to high gas line supply pressures.

DISCONNECT the furnace and its individual manual gas stop from the gas supply piping during **any pressure testing that exceeds 1/2 PSIG. (3.48 kPa).**

Natural gas supply pressure must be 5" to 10.5" w.c. LP gas supply pressure must be 11" to 13" w.c. This pressure must be maintained with all other gas-fired appliances in operation.

The minimum gas supply pressure to the gas valve for proper furnace input adjustments is 5" w.c. for natural gas, however 6" to 7" is recommended. The minimum gas supply pressure is 11" w.c. for LP gas.

CAUTION

ELEVATIONS ABOVE 2000 FT. REQUIRE THAT THE FURNACE INPUT RATING BE ADJUSTED AND THAT THE SIZE OF THE BURNER ORIFICES BE RECALCULATED BASED ON ELEVATION AND GAS HEATING VALUE. THE BURNER ORIFICES MAY (OR MAY NOT) NEED TO BE CHANGED. SEE THE SECTION TITLED "HIGH ALTITUDE INSTALLATIONS" OF THIS BOOK FOR INSTRUCTIONS.

TABLE 12
NATURAL GAS PIPE CAPACITY TABLE (CU. FT./HR.)

Capacity of gas pipe of different diameters and lengths in cu. ft. per hr. with pressure drop of 0.3 in. and specific gravity of 0.60 (natural gas).

Nominal Iron Pipe Size, Inches	Length of Pipe, Feet							
	10	20	30	40	50	60	70	80
1/2	132	92	73	63	56	50	46	43
3/4	278	190	152	130	115	105	96	90
1	520	350	285	245	215	195	180	170
1-1/4	1,050	730	590	500	440	400	370	350
1-1/2	1,600	1,100	890	760	670	610	560	530

After the length of pipe has been determined, select the pipe size which will provide the minimum cubic feet per hour required for the gas input rating of the furnace. By formula:

$$\text{Cu. Ft. Per Hr. Required} = \frac{\text{Gas Input of Furnace (BTU/HR)}}{\text{Heating Value of Gas (BTU/FT}^3\text{)}}$$

The gas input of the furnace is marked on the furnace rating plate. The heating value of the gas (BTU/FT³) may be determined by consulting the local natural gas utility or the LP gas supplier.

FIGURE 38
TWO STAGE GAS VALVE (WHITE RODGERS)

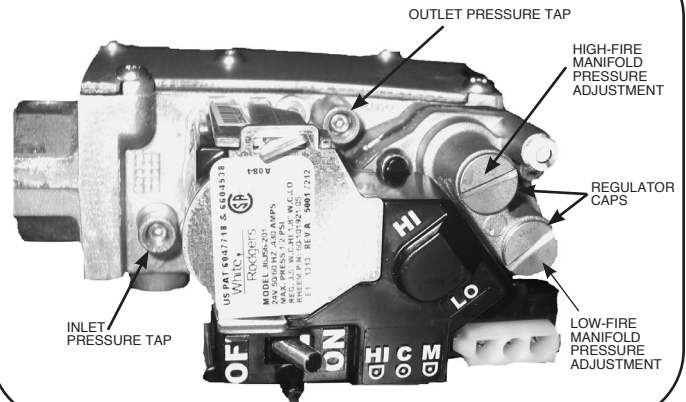

WARNING

NEVER PURGE A GAS LINE INTO THE COMBUSTION CHAMBER. NEVER USE MATCHES, FLAME OR ANY IGNITION SOURCE FOR CHECKING LEAKAGE. FAILURE TO ADHERE TO THIS WARNING CAN CAUSE A FIRE OR EXPLOSION RESULTING IN PROPERTY DAMAGE, PERSONAL INJURY OR DEATH.

TO CHECK FOR GAS LEAKAGE, USE AN APPROVED CHLORIDE-FREE SOAP AND WATER SOLUTION, OR OTHER APPROVED METHOD.

GAS VALVE

This furnace has a 24-volt gas valve. It has ports for measuring supply and manifold gas pressure. The valve body contains a pressure regulator to maintain proper manifold gas pressure.

A control switch is on the valve body. It can be set to only the "ON" or "OFF" positions. The gas valve is a slow-opening valve. See Figure 38.

When energized, it takes 2 to 3 seconds to fully open.

FIGURE 39
SINGLE STAGE WHITE RODGERS GAS VALVE

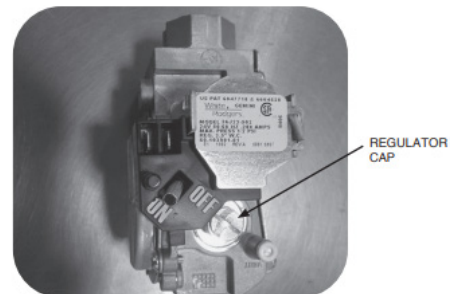

LP CONVERSION

NOTE: See Page 82 for Canadian High-Altitude Derate.

The valve can be converted to use liquified petroleum (LP) gas by replacing the pressure regulator springs with the conversion kit springs. This LP kit spring allows the regulators to maintain the proper manifold pressure for LP gas.

NOTE: Order the correct LP conversion kit from the furnace manufacturer. Furnace conversion to LP gas must be performed by a qualified installer, service agency or the gas supplier.

ORIFICE INSTALLATION

LP Gas is a manufactured gas that has consistent heating value across most regions.

The Sea Level input should still be reduced by 4% per thousand ft. and the orifice size must be selected based on the reduced input selection chart in High Alt. Instruction Section.

To change orifice spuds for either conversion to LP or for elevation:

1. Shut off the manual main gas valve and remove the gas manifold.
2. Replace the orifice spuds.
3. Reassemble in reverse order.
4. Turn the gas supply back on and check for proper operation and manifold pressure.
5. Attach the notice label alerting the next service technician that the furnace has been converted to LP gas.

WARNING

LP TANKS FROM LOCAL LP SUPPLIER MUST NOT BE USED TO STORE ANYTHING (SUCH AS FERTILIZER) EXCEPT LP GAS. THIS INCLUDES ALL DELIVERY VESSELS (LP TRUCKS). IF MATERIAL OTHER THAN LP GAS IS USED IN THE SAME VESSELS/TANK AS THE LP GAS, THE LP GAS CAN BECOME CONTAMINATED AND DAMAGE THE FURNACE. THIS WILL VOID THE MANUFACTURER'S WARRANTY. CONTACT THE SUPPLIER TO MAKE SURE FERTILIZER IS NOT USED IN THE SAME TANKS USED TO STORE AND DELIVER LP GAS.

FIGURE 40
TYPICAL LP KIT CONTENTS

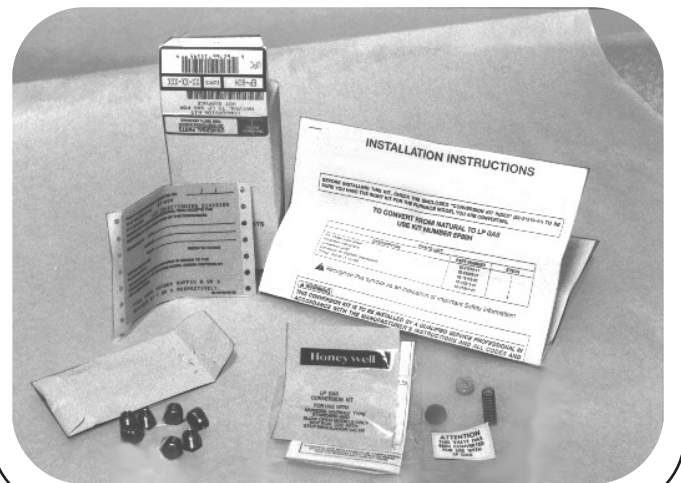

TABLE 13
LP GAS PIPE CAPACITY TABLE (CU. FT./HR.)

Maximum capacity of pipe in thousands of BTU per hour of undiluted liquefied petroleum gases (at 11 inches water column inlet pressure).

(Based on a Pressure Drop of 0.5 Inch Water Column)

Nominal Iron Pipe Size, Inches	Length of Pipe, Feet											
	10	20	30	40	50	60	70	80	90	100	125	150
1/2	275	189	152	129	114	103	96	89	83	78	69	63
3/4	567	393	315	267	237	217	196	182	173	162	146	132
1	1,071	732	590	504	448	409	378	346	322	307	275	252
1-1/4	2,205	1,496	1,212	1,039	913	834	771	724	677	630	567	511
1-1/2	3,307	2,299	1,858	1,559	1,417	1,275	1,181	1,086	1,023	976	866	787
2	6,221	4,331	3,465	2,992	2,646	2,394	2,205	2,047	1,921	1,811	1,606	1,496

Example (LP): Input BTU requirement of unit, 120,000
Equivalent length of pipe, 60 ft. = 3/4" IPS required.

GAS PRESSURE

GAS PRESSURE

SETTING GAS PRESSURE

The maximum gas supply pressure to the furnace must not exceed 10.5" w.c. natural gas, or 13" w.c. LP gas. The minimum supply gas pressure to the gas valve should be 5" w.c. natural gas or 11" w.c. LP gas. A properly calibrated manometer is required for accurate gas pressure measurements.

SINGLE STAGE SUPPLY GAS PRESSURE MEASUREMENT

An inlet pressure tap is on the input side of the gas valve.

1. With gas shut off to the furnace at the manual gas valve outside the unit, remove the inlet pressure tap plug.
2. Connect a manometer to the pressure tap.
3. Turn on the gas supply and operate the furnace and all other gas-fired units on the same gas line as the furnace.
4. Note or adjust the line gas pressure to give:
 - A. 5" - 10.5" w.c. for natural gas.
 - B. 11" - 13" w.c. for LP gas.
5. Shut off the gas at the manual gas valve and remove the manometer and hose.
6. Replace the pressure tap plug before turning on the gas.
7. Turn on the gas supply and check for gas leaks using an approved leak detector. Do **NOT** use a flame of any kind to check for leaks. Repair any leaks and repeat.

If the supply gas line pressure is above these ranges, install an in-line gas regulator to the furnace for natural gas units. With LP gas, have the LP supplier reduce the line pressure at the regulator.

If supply gas line pressure is below these ranges, either remove any restrictions in the gas supply piping or enlarge the gas pipe. See Tables 12 and 13. With LP gas, have the LP supplier adjust the line pressure at the regulator.

CAUTION

ELEVATIONS ABOVE 2000 FT. REQUIRE THAT THE FURNACE INPUT RATING BE ADJUSTED AND THAT THE SIZE OF THE BURNER ORIFICES BE RECALCULATED BASED ON ELEVATION AND GAS HEATING VALUE. THE BURNER ORIFICES MAY (OR MAY NOT) NEED TO BE CHANGED. SEE THE SECTION TITLED "HIGH ALTITUDE INSTALLATIONS" OF THIS BOOK FOR INSTRUCTIONS.

SINGLE STAGE MANIFOLD GAS PRESSURE MEASUREMENT

Natural gas manifold pressure should be 3.5" ($\pm .3$) w.c. LP gas manifold pressure should be 10.0" ($\pm .5$) w.c. Only small variations in gas pressure should be made by adjusting the pressure regulator.

1. With the gas to the unit shut off at the manual gas valve, remove the outlet pressure tap plug.
2. Connect a manometer to this pressure tap.
3. Turn on the gas supply and operate the furnace (apply a heat call).
4. Note or adjust the manifold gas pressure to give:
 - A. 3.5" ($\pm .3$) w.c. for natural gas
 - B. 10.0" ($\pm .5$) w.c. for LP gas.
5. To adjust the pressure regulator, remove the regulator cap. (See Figure 37A and 37B.)
6. Turn the adjustment screw clockwise to increase pressure, or counterclockwise to decrease pressure.
7. Securely replace the regulator caps.
8. Shut off gas at the manual gas valve and remove the manometer and hose.
9. Replace the pressure tap plug before turning on the gas.
10. Turn on the gas supply and apply a heat call to the furnace then check for gas leaks using an approved leak detector. Do **NOT** use a flame of any kind to check for leaks. Repair any leaks and repeat.

2-STAGE MANIFOLD GAS PRESSURE MEASUREMENT

Natural gas manifold pressure should be 3.5" ($\pm .3$) w.c. for high fire and 1.8" ($\pm .1$) w.c. for low fire. LP gas manifold pressure should be 10.0" ($\pm .5$) w.c. for high fire and 4.9" ($\pm .2$) w.c. for low fire. Only small variations in gas pressure should be made by adjusting the pressure regulator.

1. With the gas to the unit shut off at the manual gas valve, outside the unit.
2. Loosen (do **NOT** remove) the outlet pressure tap plug using a 3/32" allen-head wrench (see figure 37).
3. Connect a manometer to the pressure tap. The pressure tap requires a 5/16" I.D. hose.

A kit is available from Prostock Replacement Parts which includes the following:

- A. 3/32" allen-head wrench
 - B. 5/16" to 1/4" I.D. hose reducer fitting.
 - C. Short piece of 5/16" I.D. hose
- Kit part number is: F0092-100300S1
4. Turn on the gas supply and operate the furnace

GAS PRESSURE / ELECTRICAL WIRING

GAS PRESSURE

- (apply a heat all).
- Note or adjust the manifold gas pressure to give:
 - 3.5" ($\pm .3$) w.c. high fire / 1.8" ($\pm .1$) w.c. low fire natural gas.
 - 10.0 ($\pm .5$) w.c. high fire / 4.9" ($\pm .2$) w.c. low fire L.P.G.
 - To adjust the pressure regulators, remove the regulator caps. (See figure 37).
 - Turn the adjustment screw clockwise to increase pressure, or counterclockwise to decrease pressure.
 - Securely replace the regulator caps.
 - Shut off gas at the manual gas valve and remove the manometer and hose.
 - Tighten the allen-head screw in the outlet pressure tap using a 3/32" allen-head wrench (see figure 37).
 - Turn on the gas supply and apply a heat call to the furnace. Then check for gas leaks using an approved leak detector. Do NOT use a flame of any kind to check for leaks. Repair any leaks and repeat.

ELECTRICAL WIRING

WARNING

TURN OFF ELECTRIC POWER AT FUSE BOX OR SERVICE PANEL BEFORE MAKING ANY ELECTRICAL CONNECTIONS. FAILURE TO DO SO CAN CAUSE ELECTRICAL SHOCK RESULTING IN PERSONAL INJURY OR DEATH.

WARNING

THE CABINET MUST HAVE AN UNINTERRUPTED GROUND ACCORDING TO THE LATEST EDITION OF THE NATIONAL ELECTRICAL CODE, ANSI/NFPA70- OR IN CANADA, THE CANADIAN ELECTRICAL CODE, CSA-C221 OR LOCAL CODES THAT APPLY. DO NOT USE GAS PIPING AS AN ELECTRICAL GROUND. A GROUND SCREW IS PROVIDED IN THE JUNCTION BOX. FAILURE TO DO SO CAN CAUSE ELECTRICAL SHOCK RESULTING IN PERSONAL INJURY OR DEATH.

WARNING

THIS FURNACE IS EQUIPPED WITH A BLOWER DOOR SAFETY SWITCH. DO NOT DISABLE THIS SWITCH. FAILURE TO FOLLOW THIS WARNING CAN RESULT IN ELECTRICAL SHOCK, PERSONAL INJURY OR DEATH.

IMPORTANT: The furnace must be installed so that the electrical components are protected from water (condensate).

Before proceeding with the electrical connections, be certain that the voltage, frequency and phase corresponds to that specified on the furnace rating plate. For single

furnace application, maximum over-current protection is 15 amperes.

Use a separate fused branch electrical circuit containing a properly sized fuse or circuit breaker. Run this circuit directly from the main switch box to an electrical disconnect that is readily accessible and located near the furnace (as required by code). Connect from the electrical disconnect to the junction box on the left side of the furnace, inside the blower compartment. For the proper connection, refer to the appropriate wiring diagram located on the inside cover of the furnace control box and in these instructions.

NOTE: The electrical junction box may be moved to the right side if necessary. A knockout is provided. Seal the opposite hole with plug provided.

NOTE: L1 (hot) and L2 (neutral) polarity must be observed when making field connections to the furnace. The ignition control may not sense flame if L1 and L2 are reversed. Make all electrical connections in accordance with the latest edition of the National Electrical Code;

ANSI/NFPA70 or, in Canada, The Canadian Electrical Code and local codes having jurisdiction.

These may be obtained from:

National Fire Protection Association, Inc.
Batterymarch Park
Quincy, MA 02269

FIGURE 41
DOOR SWITCH REMOVAL INSTRUCTIONS

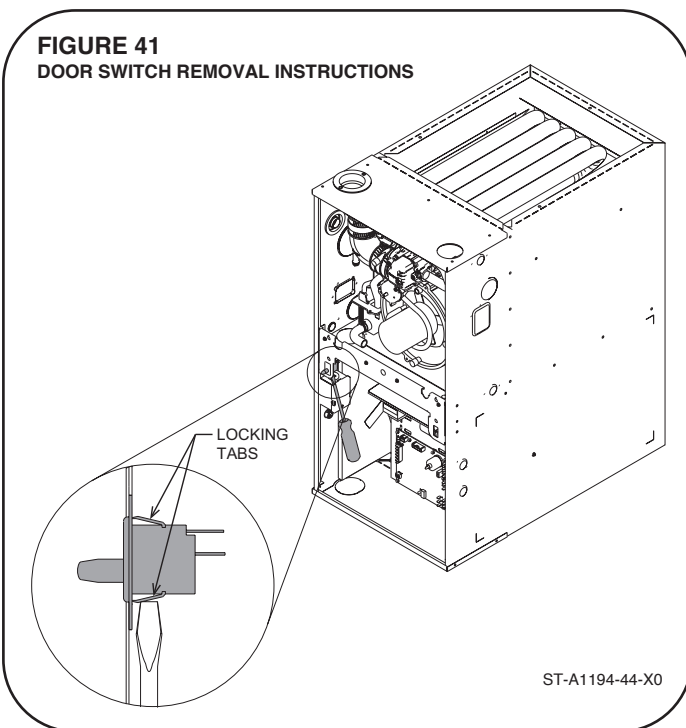

ST-A1194-44-X0

CSA - International
5060 Spectrum Way
Mississauga, Ontario
Canada L4W 5N6
online: www.csa.ca

ELECTRICAL WIRING

REVERSING ELECTRICAL CONNECTION & THERMOSTAT

REVERSING THE ELECTRICAL CONNECTION (JUNCTION BOX)

If the line voltage electrical needs to be moved to the opposite side of the furnace, the following steps should be taken:

1. The furnace must NOT be electrically connected to line voltage prior to reversing the electrical connection.
2. Disconnect the wires from the door switch.
3. Remove the junction box from the furnace cabinet wall by removing the two screws that hold it to the cabinet. Leave the wires connected to the junction box.
4. Remove 7/8" plug from hole opposite j-box location. Drill 2 @ 3/16" Ø holes in the jacket. **NOTE:** Dimples/marks are provided in the sheet metal for correct drilling location.
5. Move the junction box to the opposite side of the cabinet. Install using the two screws removed in step 3 above. Note that all screws penetrating the junction box must be blunt – no sharp tipped screws can be used.
6. Replace the plug from the opposite of the furnace (the new j-box location) to the old j-box location and install qty=2 1/4" plugs from parts bag in empty screw holes in old location of j-box into the mounting screw holes in the old junction box location.
7. Using a flat screwdriver, squeeze the retaining arms on the door switch and gently pry the door switch from its opening as shown in Figure 41.
8. Install the door switch in the same opening on the opposite of the furnace and reconnect the electrical connectors (removed in Step 2) to the door switch.

FIGURE 42
LINE VOLTAGE CONNECTIONS

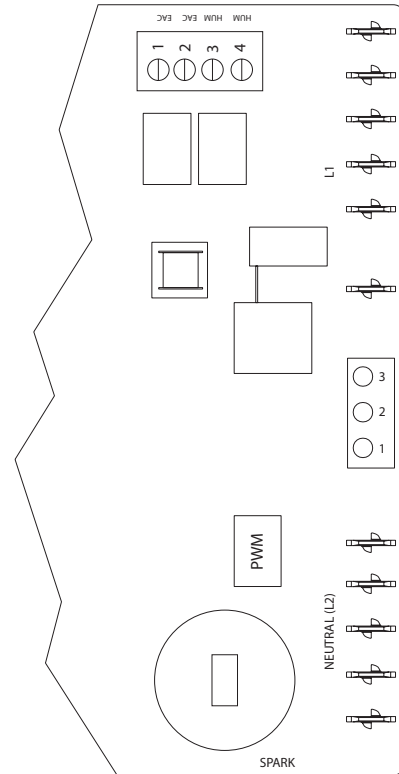

ST-A1325-01

THERMOSTAT

The room thermostat must be compatible with the furnace. See manufacturer's thermostat spec sheet for compatibility concerns. Generally, all thermostats that are not of the "current robbing" type are compatible with the integrated furnace control. The low voltage wiring should be sized as shown.

NOTE: Do not use 24 volt control wiring smaller than No. 18 AWG.

Install the room thermostat in accordance with the instruction sheet packed in the box with the thermostat. Run the thermostat lead wires inside the blower compartment and connect to low voltage terminals as shown on the wiring diagram. Never install the thermostat on an outside wall or where it will be influenced by drafts, concealed hot or cold water pipes or ducts, lighting fixtures, radiation from fire-place, sun rays, lamps, televisions, radios or air streams from registers.

FIELD INSTALLED OPTION ACCESSORIES

ELECTRONIC AIR CLEANER (AVAILABLE ONLY IN 2 STAGE)

The electronic air cleaner contacts (labeled “EAC” (2)) are “dry” contacts on the IFC that can support up to 230V and 1.0 amps. The dry contacts are connected directly to the contacts of a board-mounted relay. The coil of the relay is controlled by the microprocessor of the IFC. The coil is engaged whenever the blower motor is energized. The EAC terminals are enabled automatically (No setup required in thermostat or Bluetooth app).

Some lower fan speeds may not deliver enough airflow to operate an electronic air cleaner. The IFC determines the minimum airflow necessary to operate an electronic air cleaner and will not turn on the EAC unless the necessary airflow is met.

NOTE: Maximum current is 1.0 amps for the electronic air cleaner output.

LP CONVERSION KITS

For 2- Stage LP Conversion Kits:
RXGJ-FP34 White Rodgers Valve

For Single Stage LP Conversion Kits:
RXGJ-FP38 Universal: All Valves
RXGJ-FP36 White Rodgers Valve
RXGJ-FP33 Honeywell Valve

HUMIDIFIER

On 2 stage furnaces, humidifier output is a set of dry contacts with an additional 1/4” terminal labeled “HUM” that will supply line voltage whenever the induced draft motor is energized. The logic controlling these dry contacts and the necessary wire diagrams for installing a humidifier are detailed in the section of this manual titled Humidification/ Dehumidification. 2 stage furnaces can use the dry contacts by setting up in the EcoNet thermostat or through the Bluetooth app. The 1/4” terminal labeled “HUM” can be used without any setup in thermostat or app. Single stage furnaces will only have the 1/4” terminal labeled “HUM”.

FILTERS (See Figure 43)

Keep filters clean at all times. **A filter is not provided with the furnace, but one must be field-supplied and installed.**

It is recommended to replace the furnace filter periodically to maintain optimum furnace performance.

TWINNING

Twinning of these furnaces is NOT permitted!

AIR TEMPERATURE SENSORS (AVAILABLE ONLY IN 2 STAGE)

Outdoor Air Temperature Kit RXGJ-J02

Supply Air Temperature Sensor 47-24225-01

Refer to supply and outdoor air temperature section of integrated furnace control for more information.

ACCESSORIES

FIELD INSTALLED OPTION ACCESSORIES (cont.)

FIGURE 43
FILTER LOCATIONS

UPFLOW/HORIZONTAL

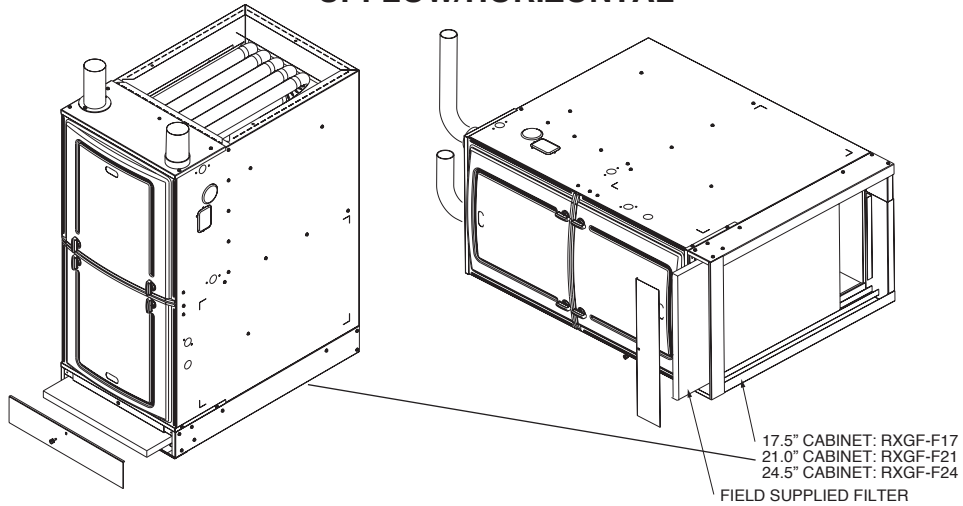

ST-A1194-10-X0

SIDE RETURN

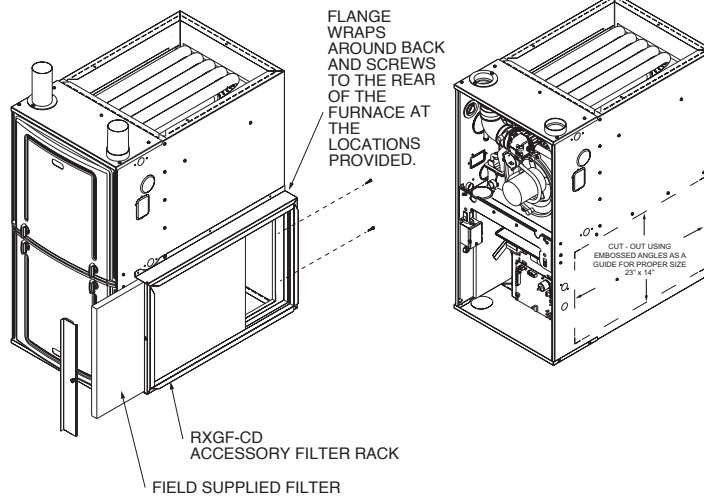

ST-A1194-11-X0

HORIZONTAL/DOWNFLOW

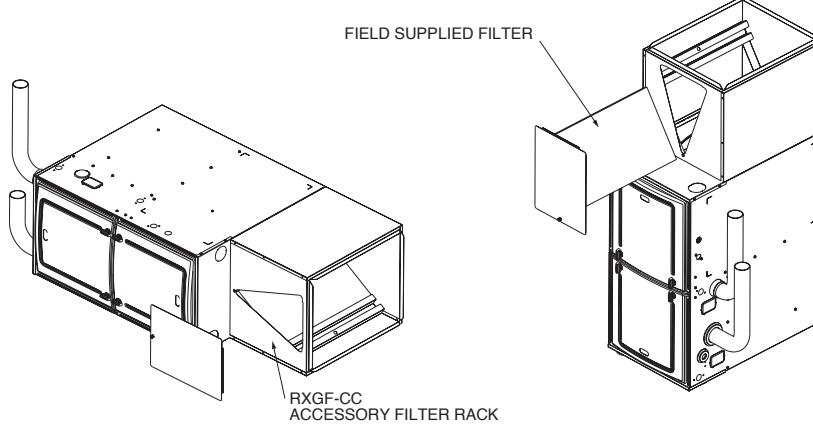

ST-A1194-12-X0

NATURAL GAS AT HIGH ALTITUDES

No high altitude pressure switch changes are required; only a 4% derate per 1,000 ft. at altitudes above 2,000 feet above sea level.

NATURAL GAS

CAUTION

INSTALLATION OF THIS FURNACE AT ALTITUDES ABOVE 2000 FT. (610 M) SHALL BE IN ACCORDANCE WITH LOCAL CODES, OR IN THE ABSENCE OF LOCAL CODES, THE NATIONAL FUEL GAS CODE, ANSI Z223.1/NFPA 54 OR IN CANADA, NATURAL GAS AND PROPANE INSTALLATION CODE, CSA B149.1.

CAUTION

ELEVATIONS ABOVE 2000 FT. REQUIRE THAT THE FURNACE INPUT RATING BE ADJUSTED AND THAT THE SIZE OF THE BURNER ORIFICES BE RE-CALCULATED BASED ON ELEVATION AND GAS HEATING VALUE. THE BURNER ORIFICES MAY (OR MAY NOT) NEED TO BE CHANGED. THE FOLLOWING EXAMPLES SHOW HOW TO DETERMINE IF AN ORIFICE CHANGE WILL BE NECESSARY AND HOW TO DETERMINE THE NEW ORIFICE SIZE.

IN CANADA, AS AN ALTERNATE TO ADJUSTING THE BURNER ORIFICE SIZE, THE MANIFOLD GAS PRESSURE MAY BE ADJUSTED. THIS METHOD IS COVERED LATER IN THIS SECTION. THIS METHOD OF ADJUSTING MANIFOLD PRESSURE MAY ONLY BE USED IN CANADIAN INSTALLATIONS.

NOTE: Factory installed orifices are calculated and sized based on a sea level Natural Gas heating value of 1100 BTU per cubic ft. Regional reduced heating values may nullify the need to change orifices except at extreme altitudes.

The following are examples of orifice sizing using the *National Fuel Gas Code Annex E, Tables E1.1(a) and E1.1(d), 2015 edition*. For a simplified estimation of orifice size based on heating value and elevation, use Table 14 on the following page. However, calculations as shown are the best method.

Example:

Use the formula below to calculate the amount of gas used per hour based on the Regional Heating Value of 900BTU/ft³.

$$I / H = Q$$

Where:

I = BTU input of burner at seal level (btu)

H = regional heating value of natural gas at seal level (btu/ft³)

Q = volume of natural gas per hour (ft³)

I = 14000 BTU. For this furnace the input per burner is 14,000 BTU.

H = 900 BTU/ft³. Obtain the natural gas heating value from your regional natural gas provider. For this example we will use a Regional Natural Gas Heating Value 900 btu/ft³.

Q = Calculate for the volume of natural gas per hour.

$$14,000 / 900 = Q$$

$$15.56 \text{ FT}^3 = Q$$

The volume of natural gas used on this furnace at sea level is 15.56 ft³ per hour. Use this value to locate the orifice size in table **Table E1.1(a)** of *National Fuel Gas Code, 2015 edition* (3.5" water column). Orifice required at sea level is : #49.

Use this orifice size to find derated orifice sizes for elevations on **Table E1.1(d)** of *National Fuel Gas Code, 2015 edition*.

Orifice required at 5000 ft. elevation (4% de-rate per thousand ft. above sea level): #51

Orifice required at 8000 ft. elevation (4% de-rate per thousand ft. above sea level): #52

HIGH ALTITUDE

NATURAL GAS AT HIGH ALTITUDES (cont.)

TABLE 14

NATURAL GAS ORIFICE SELECTION BASED ON HEATING VALUE & ELEVATION*

Notes:

1. All 92%, 95% single stage and 96% two stage units are factory equipped with orifices sized for 1100 sea level heating value gas.
2. Installer must be aware of the local heating value (sea level standard) to use the chart below.
3. This chart is based on the National Fuel Gas Code (NFGC) Annex E, 2015 Edition, based on natural gas with a specific gravity of 0.60
4. The recommended orifices below allow the furnace to operate within 10% of design rate. However, NFGC calculations are the best method.
5. Furnace operation is optimized when operating at design rate. Installer is responsible to verify rate.
6. This table applies to 90+ models only with 14,000BTU/Burner. DO **NOT** USE THIS CHART FOR ANY 80+ FURNACE MODEL.

Grey Cells Indicate Factory Orifice Size		ELEVATION									
		Sea Level to 1,999'	2,000' to 2,999'	3,000' to 3,999'	4,000' to 4,999'	5,000' to 5,999'	6,000' to 6,999'	7,000' to 7,999'	8,000' to 8,999'	9,000' to 9,999'	10,000'
Gas Heating Value (BTU's/ft ³) @ Sea Level**	1,000-1,100	52	52	53	53	53	53	53	54	54	54
		51	51	52	52	52	52	53	53	53	54
		50	51	51	51	51	52	52	52	53	53
	900-999	51	51	52	52	52	52	53	53	53	54
		50	51	51	51	51	52	52	52	53	53
		49	50	50	50	51	51	51	52	52	52
	800-899	50	51	51	51	51	52	52	52	53	53
		49	50	50	50	51	51	51	52	52	52
		48	49	49	49	50	50	50	51	51	52
	700-799	48	49	49	49	50	50	50	51	51	52
		47	48	48	49	49	49	50	50	51	51
		46	47	47	47	48	48	49	49	50	50
		45	46	47	47	47	48	48	49	49	50

*Table is derived from Annex E, 2015 Edition of the *National Fuel Gas Code*. To determine the correct orifice for your installation consult the *National Fuel Gas Code* tables E1.1(a) and E1.1(d), 2015 Edition

**Be sure to use sea level heating value. When requesting the heating value from a local utility, it must be converted to sea level equivalent in order to use this table.

Note: Above 5,000ft, the last 2 elbows on an alternate horizontal termination which are on the exterior of the building will be counted in the maximum vent length and maximum number of elbows permitted.

LP GAS AT HIGH ALTITUDES

ORIFICE INSTALLATION

LP Gas is a manufactured gas that has consistent heating value across most regions.

The NFGC guidelines are used with the following exception:

The recommended LP Gas high altitude orifice selections differ slightly in that the NFGC LP orifice chart, as they are not accurate for this furnace product. The National Fuel Gas Code LP orifices are based on an 11" of water column pressure at the orifice, which differs from this furnace product that use 10" of water column at the orifice. This difference requires a deviation from the NFGC orifice size recommendations. The Sea Level input should still be reduced by 4% per thousand ft. and the orifice size must be selected based on the reduced input selection Table 15.

ORIFICE ORDERING INFORMATION

Orifice sizes are selected by adding the 2-digit drill size required in the orifice part number. Drill sizes available are 39 through 64; metric sizes available 1.10mm (-90):

Orifice Part Number 62-22175-(drill size)

Example 1:

60 drill size orifice required
Part # 62-22175-60

Example 2:

1.10 mm drill size orifice required
Part # 62-22175-90

ALTERNATE METHOD OF CANADIAN HIGH-ALTITUDE DERATE

In Canada, unless an orifice change is specifically mandated by local codes, an alternate method of altitude deration through a reduction in manifold pressure is acceptable as described in Table 16.

The information in Table 16 is based on a heating value of 1000 BTU per cubic feet of natural gas, and 2500 BTU per cubic feet of LP gas.

IMPORTANT: Actual input rates must be measured on-site with manifold pressure adjustment to ensure that an actual 10% reduction in input rate is achieved.

Once this field adjustment has been made, the label shown in Figure 44 must be affixed in a conspicuous location on the front of the furnace cabinet:

NOTE: This label is supplied in the information packet shipped with each furnace.

Altitude	Input (per burner) 14000	Orifice Size
0 to 2000 ft.	14,000	1.10 mm (factory kit)
2000'-3000'	12,880	#57
3000'-4000'	12,320	#58
4000'-5000'	11,760	#59
5000'-6000'	11,200	#60
6000'-7000'	10,640	#61
7000'-8000'	10,080	#62
8000'-9000'	9,525	#63
9000'-10000'	8,960	#64

TABLE 16
ALTERNATE METHOD FOR CANADIAN HIGH-ALTITUDE DERATE
IMPORTANT: 90 Plus Models only.

NATURAL GAS					LP GAS				
ALTITUDE	INPUT	OUTPUT	ORIFICE SIZE	MANIFOLD PRESSURE	ALTITUDE	INPUT	OUTPUT	ORIFICE SIZE	MANIFOLD PRESSURE
0' - 2000'	42,000	39,900	#51	3.5" W.C.	0' - 2000'	42,000	39,900	1.10mm	10" W.C.
	56,000	53,200				56,000	53,200		
	70,000	66,500				70,000	66,500		
	84,000	79,800				84,000	79,800		
	98,000	93,100				98,000	93,100		
112,000	106,400	112,000	106,400						
2001' - 4500'	37,800	35,910	#51	3.0" W.C.	2001' - 4500'	37,800	35,910	1.10mm	7.6" W.C.
	50,400	47,880				50,400	47,880		
	63,000	59,850				63,000	59,850		
	75,600	71,820				75,600	71,820		
	88,200	83,790				88,200	83,790		
100,800	95,760	100,800	95,760						

FIGURE 44
MANIFOLD PRESSURE-CHANGE LABEL

THE MANIFOLD PRESSURE OF THIS APPLIANCE HAS BEEN FIELD ADJUSTED TO OBTAIN THE CORRECT INPUT RATING FOR INSTALLATION AT ALTITUDES BETWEEN 2,000 FEET AND 4,500 FEET ELEVATION.

LA PRESSION DU DISTRIBUTEUR D'ALIMENTATION DE CET APPAREIL A ÉTÉ AJUSTÉ SUR LES LIEUX AFIN D'OBTENIR LA BONNE PUISSANCE D'ENTRÉE POUR UNE INSTALLATION ENTRE 2000 ET 4500 PIEDS D'ALTITUDE.

92-24399-01-01

COMMUNICATING FURNACE CONTROL

START-UP AND SEQUENCE OF OPERATIONS

This furnace is equipped with a direct ignition control. Each time the room thermostat calls for heat, the ignitor lights the main burners directly. See the lighting instructions on the furnace.

TO START THE FURNACE

1. Remove the burner compartment control access door.
2. **IMPORTANT:** Be sure that the manual gas control has been in the "OFF" position for at least five minutes. Do not attempt to manually light the main burners.
3. Turn off the furnace electrical power and set the room thermostat to its lowest setting.
4. Turn the gas control to the "ON" position or move the gas control lever to the "On" position.
5. Replace the burner compartment control access door.
6. Turn on the furnace electrical power.
7. Set the room thermostat to a point above room temperature to light the main burners. The heat call should be adequate to activate the high stage gas heat – generally, the thermostat setpoint should be more than 2°F above room temperature. Consult your thermostat specs to be sure.
8. Operate high gas heat for a minimum period of 15 minutes and adjust input rate (See Section of this book titled **Adjusting Input Rate**) and observe condensate system for leaks. Correct leaks and set rate, shut down furnace and repeat until no leaks in condensate system can be detected.
9. Once high heat operation has been successfully verified and rate adjusted, the thermostat should be adjusted to set the heat call to low stage. This is generally with the heating setpoint at about 1°F above room temperature. Consult your thermostat specs to be sure.
10. Operate low gas heat for a minimum period of 15 minutes and adjust input rate (page 88) and observe condensate system for leaks. Correct leaks and set rate, shut down furnace and repeat until no leaks in condensate system can be detected.

TO SHUT DOWN THE FURNACE

1. Set the room thermostat to its lowest setting and wait for furnace to shut down.
2. Remove the burner compartment control access door.
3. Shut off the gas to the main burners by turning the gas control to the "OFF" position.

SEQUENCE OF OPERATION

CONTROLS Integrated Controls with Direct Spark Ignition.

1. Each time the thermostat "W" (Heating) contacts close

WARNING

SHOULD OVERHEATING OCCUR OR THE GAS SUPPLY FAIL TO SHUT OFF, CLOSE THE MANUAL GAS VALVE FOR THE APPLIANCE BEFORE SHUTTING OFF THE ELECTRICAL SUPPLY. FAILURE TO DO SO CAN CAUSE AN EXPLOSION OR FIRE RESULTING IN PROPERTY DAMAGE, PERSONAL INJURY OR DEATH.

- (legacy) or a communicating heat call is transmitted to the furnace control from a communicating thermostat, the furnace control checks to make sure that both pressure switches are open. This is true of a low or high heat call as "W" is energized on either call. Next the induced draft blower (inducer) begins a pre-purge cycle at high stage.
2. The air proving negative pressure switches (both low and high) close.
3. After the 30-second pre-purge, **the gas valve opens on high stage for an 8-second trial for ignition.**
4. The spark igniter is energized to light the gas burners and **stays energized for the up to 7 seconds after the gas valve opens.**
5. Eight seconds after the gas valve opens **the remote flame sensor must prove flame ignition for one second** using the process of flame rectification. If the burners don't light, the system goes through another ignition sequence. It does this **up to four times** before entering a 1-hour lockout.
6. Twenty seconds after flame is sensed, the gas valve is set to the thermostat demand (low or high) (note if thermostat demand is high, the gas valve is already at high stage and will not switch) and the main blower will be energized at either the low or high gas heat stage depending on the thermostat demand.
7. When the thermostat "W" (legacy) or communicated heat call ends, the gas valve closes, flame is extinguished, the induced draft blower stops after a **10-second post-purge**, and the negative pressure switch opens.
8. The main blower continues until timed off by the setting on the integrated furnace control board.

Sequence if the system doesn't light or doesn't sense flame:

1. Each time the thermostat "W" (Heating) contacts close, the furnace control checks to make sure that both pressure switches are open. This is true of a low or high heat call as "W" is energized on either call. Next the induced draft blower (inducer) begins a pre-purge cycle at high stage.
2. After the 30-second pre-purge, **the gas valve opens on high stage for an 8-second trial for ignition.**

INTEGRATED FURNACE CONTROL

FIGURE 45
COMMUNICATING FURNACE CONTROL LAYOUT

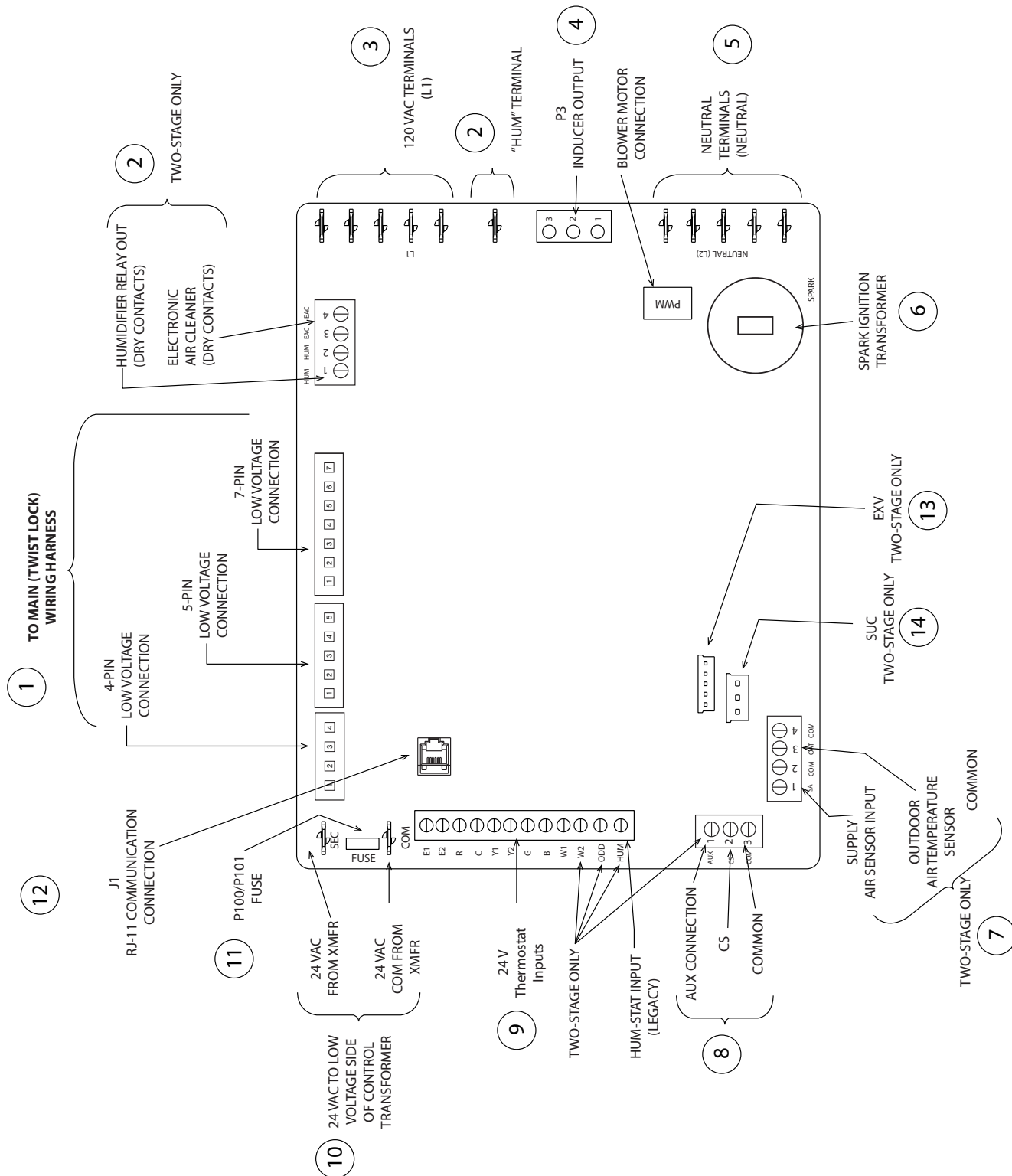

ST-A1325-02

INTEGRATED FURNACE CONTROL

1. **4-Pin, 7-Pin and 5-Pin - Low-Voltage Internal Wiring** Connections – Connect main twis lock wire harness to these connections. Pre-wired from the factory.

2. **ELECTRONIC AIR CLEANER (E.A.C.) OUTPUT (AVAILABLE ONLY IN 2 STAGE)** The electronic air cleaner contacts (labeled “EAC” (2)) are “dry” contacts on the IFC that can support up to 230V and 1.0 amps. The dry contacts are connected directly to the contacts of a board-mounted relay. The coil of the relay is controlled by the microprocessor of the IFC. The coil is engaged whenever the blower motor is energized. The EAC terminals are enabled automatically (No setup required in thermostat or Bluetooth app).

Some lower fan speeds may not deliver enough airflow to operate an electronic air cleaner. The IFC determines the minimum airflow necessary to operate an electronic air cleaner and will not turn on the EAC unless the necessary airflow is met.

HUMIDIFICATION AND DEHUMIDIFICATION HUMIDIFIER (AVAILABLE ONLY IN 2 STAGE) – The humidifier contacts (labeled “HUM” (2)) are “dry” contacts on the IFC that can support up to 230V and 1.0 amps. The dry contacts are connected directly to the contacts of a board-mounted relay. The coil of the relay is controlled by the microprocessor of the IFC. The coil is engaged whenever the minimum CFM is met in a heating call and (1) 24VAC is present on the thermostat terminal of the IFC labeled “HUM STAT” or (2) a communicating thermostat with humidification and dehumidification capability is installed with a call for humidification present. Minimum CFM for humidification can be set up in the EcoNet thermostat. If a legacy thermostat is being used, a minimum RPM will automatically be set to ensure humidification is enabled whenever a heat call is present and there is 24VAC present on the “HUM STAT” terminal.

Humidification/Dehumidification through the thermostat is only available on two-stage furnaces. Dehumidification can be set up through an EcoNet thermostat or through the Bluetooth app.

For single stage furnaces, line voltage power is supplied from the terminal labeled “HUM”. This will supply line voltage to the humidifier whenever the induced draft motor is energized. Neutral from the humidifier can be connected to a line voltage neutral terminal on the control board. This option can also be used for two-stage furnace with a legacy thermostat.

NOTE: Maximum current - 1.0 amps for each option (humidifier or electronic air cleaner). (See Figure 45 for location of humidification/dehumidification inputs on furnace control.)

3. **LINE VOLTAGE CONNECTIONS (120VAC, L1)** Four ¼” Quick-Connect style terminals are provided for internal connections and accessories

4. **INDUCED DRAFT MOTOR (INDUCER) OUTPUT** This three-pin Mate-n-Lok style connector provides power to both the high and low speed inducer outputs.

5. **NEUTRAL TERMINALS (N)** Four ¼” Quick-Connect style terminals are provided for internal connections and accessories.

6. **SPARK IGNITION TRANSFORMER** The spark ignition transformer resides on the furnace-control. The transformer provides spark energy at approximately 60 hz frequency and a minimum of 12KV.

7. Put #16 “Supply and Outdoor air temperature sensor input” here, and update the section.

8. **AUXILIARY INPUTS (COMMUNICATING SYSTEMS ONLY) (SEE FIGURE 52)**

Terminal is provided for field installation of up to two auxiliary switches. The auxiliary inputs shall be used to provide a means of using traditional drain pan switches, smoke detectors, freeze switches, etc. The inputs are to be labeled Aux 1 and Aux 2. The switch inputs are for communicating systems only. One or both inputs can be configured at the communicating thermostat as either normally open or normally closed contacts. System operation when the contacts either open or close can be configured at the Econet Thermostat.

A resistance of greater than 1k ohms to common shall be detected as an open switch and a resistance of less than 100 ohms shall be recognized as a closed switch.

9. **THERMOSTAT INPUTS – THERMOSTAT WIRING DIAGRAMS**

Both communicating and 24V legacy thermostats are to be connected at terminal block.

Max Wire Length – Between any 2 devices = 125 FT @ 18 AWG*

Sum Max Total Wire Length for All Components = 500 ft (see Figure 53)

Notes:

1. Wires may be solid or stranded.
2. *Wire gauge smaller than 18 AWG is not approved or recommended for this application.

3. If the thermostat wiring will be located near or in parallel with high voltage wiring, cable TV, Ethernet wiring, or radio frequency equipment, then shielded thermostat wire can be used to reduce or eliminate potential interference. The shielding must be contiguous (have continuity) across all devices and all wire segments. This should be done by twisting the shielding wires from adjacent segments together. Further, the shielding for the entire system must be grounded in a single location. Multiple grounds on the shielding

INTEGRATED FURNACE CONTROL

system are NOT permitted. The shield wire should be connected to the C terminal, or ground, at the indoor unit. The shield wire should NOT be connected to any terminal at the Control Center (aka;Thermostat). Connecting the shield to ground at both ends can cause current loops in the shield, reducing shield effectiveness.

4. When using existing wire from a previous installation, be sure to trim the tip of the wire back past the insulation and strip a small amount of insulation from the wire to expose clean new copper for the communicating connections. Fresh copper must be exposed when making the communicating connections or communications may not be properly established.

10. 24VAC AND COMMON CONNECTIONS

For connection to the low voltage side of the control transformer. Terminals are ¼" quick-connect style.

11. FUSE

A fuse is provided to protect low-voltage (24VAC) circuits from shorts between 24VAC and Ground or Common.

12. RJ-11 COMMUNICATION CONNECTION

This connector is used to program the furnace control at the factory. It should never be connected to a telephone line or a telephone. Doing so could damage the furnace control or the telephone (or telephone lines) or both.

▲ WARNING

DO NOT CONNECT A TELEPHONE OR PHONE LINE TO THE CONNECTOR (JACK) AT POSITION J-11. DOING SO COULD CAUSE IRREPARABLE DAMAGE TO EITHER THE FURNACE CONTROL (I.F.C.) OR THE TELEPHONE (OR TELEPHONE LINE) OR BOTH.

13. EXV (2-Stage only)

Connector provided for evaporator coils equipped with an EXV control.

14. SUC. PRESS (2-Stage only)

Connector provided for evaporator coils equipped with an EXV control system.

FIGURE 46
ELECTRONIC AIR CLEANER AND HUMIDIFIER TERMINALS
TWO STAGE ONLY

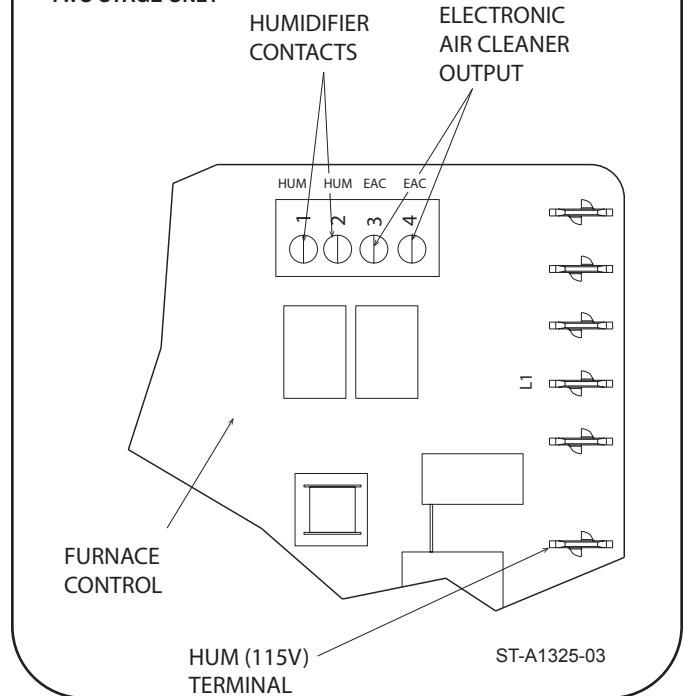

INTEGRATED FURNACE CONTROL

HUMIDIFICATION/DEHUMIDIFICATION

Two stage humidification/dehumidification can be used with communicating stat or legacy stat in conjunction with the Bluetooth app and an external humidistat.

Humidification: external humidifier will need to be installed on the (2) HUM terminals.

Dehumidification: Reduces airflow in cooling by approximately 15% to lower humidity

Communicating stat uses an internal humidistat in the control center to operate the dehumidification and will energize the (2) hum dry contacts for humidification mode.

Legacy stat will require an external humidistat and must be installed in series between R and ODD for dehumidification and R and HUM for humidification. Two separate conditions must be met before humidification can begin on a legacy system

- 1.) There must be a call for heat and the blower must be engaged
- 2.) The humidistat must determine that there is a need for humidification.

To determine which wiring diagram and method to use, select from the following configurations:

A. HUMIDIFICATION NO DEHUMIDIFICATION REQUIRES ADDITIONAL HUMIDIFIER

A1. COMMUNICATING THERMOSTAT TWO STAGE ONLY (SEE FIG. 47A)

- Wire humidifier to the (2) HUM contacts
- Select humidification in the thermostat settings & set minimum CFM. This value must be met for contacts to energize.

A2. LEGACY THERMOSTAT

(See FIG. 47B)

A2.1. CONTINUOUS HUMIDIFIER OPERATION DURING HEATING.(2 stage only)

- Wire humidifier to the (2) HUM contacts
- Jumper “R” & “HUM STAT”
- Enable humidification in the contractor app settings via Bluetooth.

A2.2 . CONTINUOUS HUMIDIFIER OPERATION DURING HEATING

(1 STAGE ONLY) See FIG 47C

- Humidifier is wired to 115V ¼” Spade terminal and is active anytime the inducer is energized. Max load 1A.

A separate humidistat is not required for continuous humidifier operation and the humidifier will turn on whenever there is a call for heat and the blower is running.

FIGURE 47A
HUMIDIFICATION CONTROL WITH COMMUNICATING THERMOSTAT(TWO STAGE ONLY) (REQUIRES OPTIONAL HUMIDIFIER)

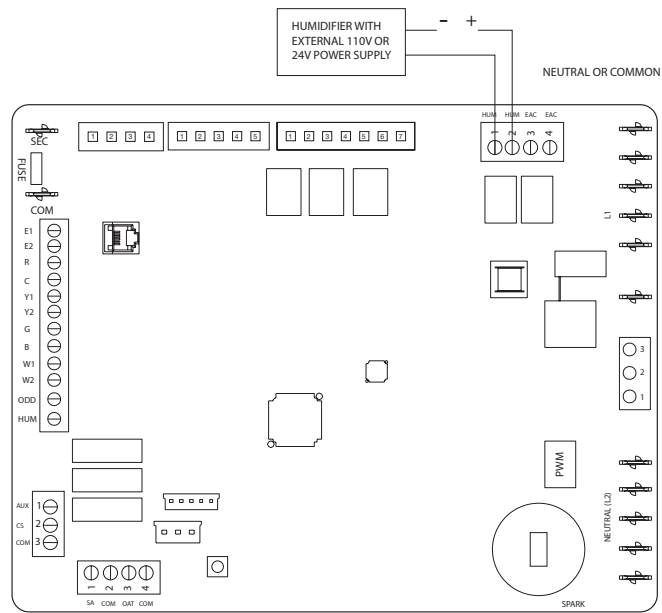

ST-A1325-19

INTEGRATED FURNACE CONTROL

HUMIDIFICATION/DEHUMIDIFICATION

FIGURE 47B
 HUMIDIFICATION CONTROL WITH NON-COMMUNICATING THERMOSTAT(TWO STAGE ONLY) (REQUIRES OPTIONAL HUMIDIFIER).
 THIS WILL CONTINUOUSLY RUN HUMIDIFIER DURING HEAT CALL.

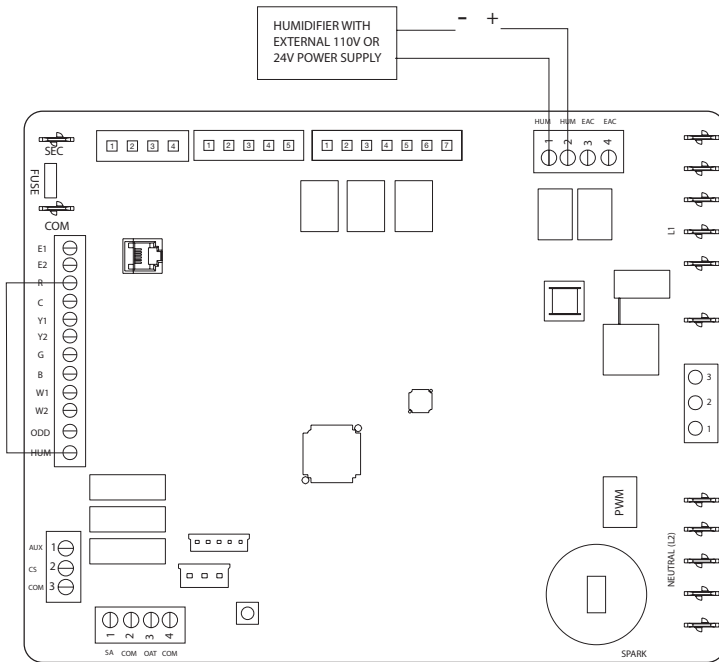

ST-A1325-20

FIGURE 47C
 HUMIDIFICATION CONTROL WITH NON-COMMUNICATING THERMOSTAT(1 STAGE ONLY) (REQUIRES OPTIONAL HUMIDIFIER).
 THIS WILL CONTINUOUSLY RUN HUMIDIFIER DURING HEAT CALL.

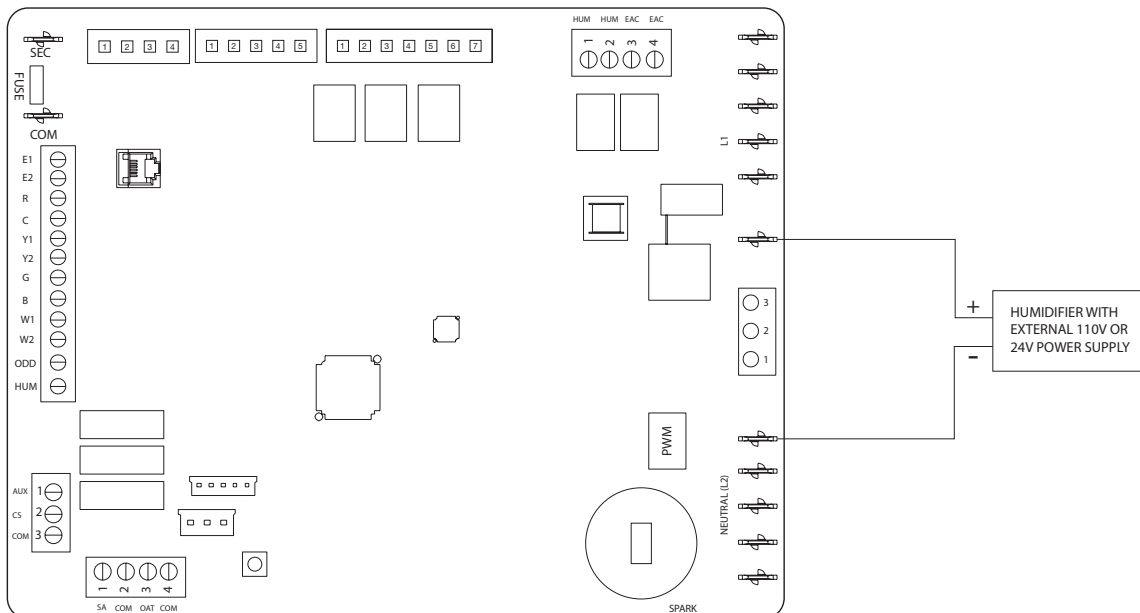

ST-A1325-21

INTEGRATED FURNACE CONTROL

HUMIDIFICATION/DEHUMIDIFICATION

A2.3 CONTROLLED HUMIDIFIER OPERATION USING A HUMIDISTAT (REQUIRES HUMIDISTAT AND HUMIDIFIER)

Controlled humidification can be accomplished using a humidistat as shown in Figure 48 or 49.

These figures show installation of a humidifier with external and internal power supplies, respectively.

- Humidification will need to be enabled via Bluetooth app.

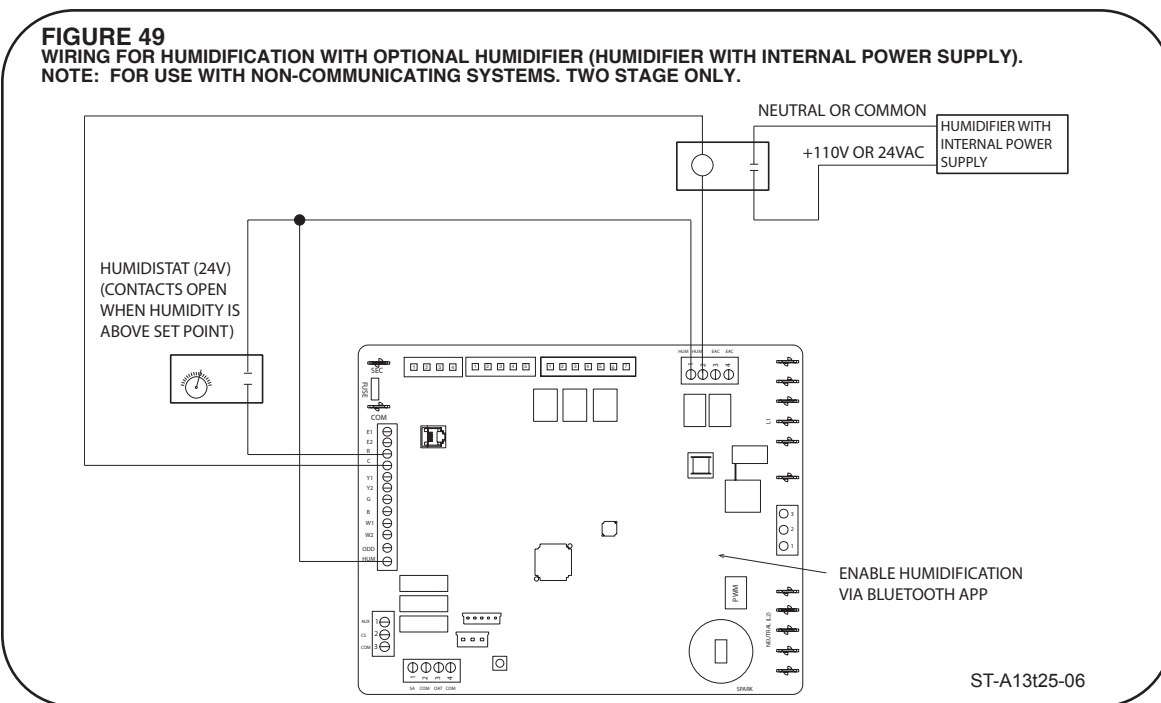
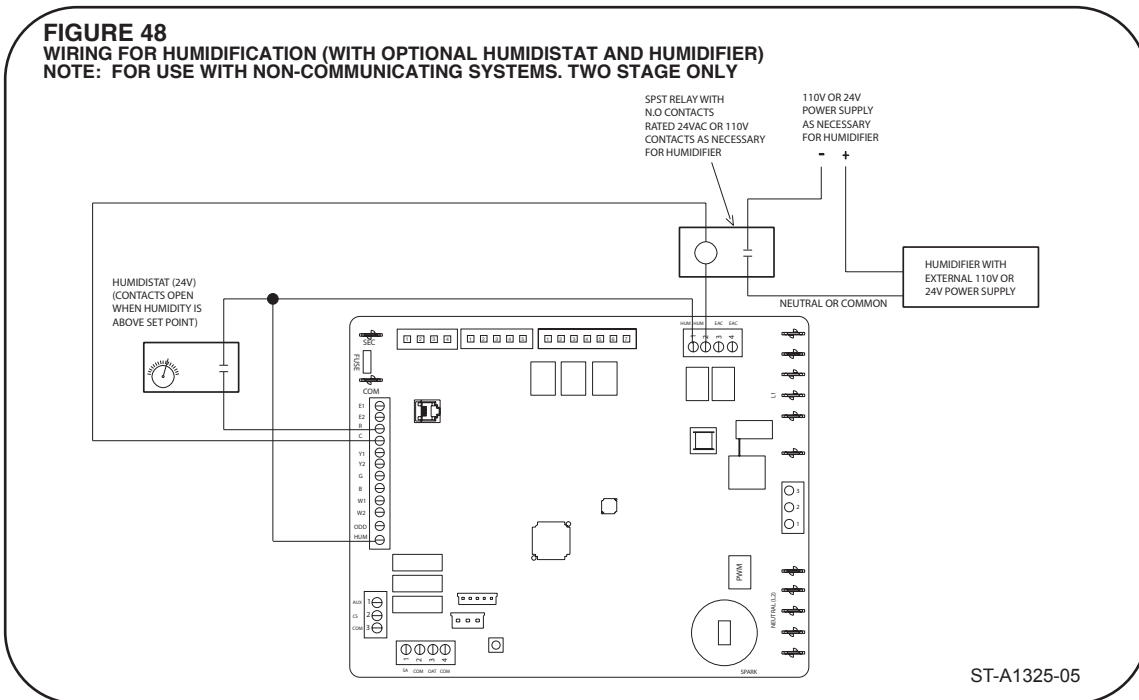

INTEGRATED FURNACE CONTROL

HUMIDIFICATION/DEHUMIDIFICATION

B. DEHUMIDIFICATION CONTROL WITH NO HUMIDIFICATION

B1. WITH COMMUNICATING THERMOSTAT 1&2-STAGE

- Dehumidification is controlled through the econet thermostat when enabled through the thermostat. Airflow will be reduced by the thermostat when dehumidification is required.
- No additional wiring is required for dehumidification with econet thermostat.

B2. WITH NON-COMMUNICATING THERMOSTAT (REQUIRES HUMIDISTAT) 2-STAGE ONLY

- Dehumidification only (no humidification) can be accomplished by installing a humidistat as shown in figure 50. Requires dehumidification to be enabled via bluetooth app.
- Enabling dehumidification without the use of a humidistat is not advised. This will continuously reduce airflow by approx. 15%.

FIGURE 50
 HUMIDISTAT USED TO CONTROL DEHUMIDIFICATION IN COOLING ONLY (NO HUMIDIFIER)
 NOTE: FOR USE WITH NON-COMMUNICATING THERMOSTATS. TWO STAGE ONLY.

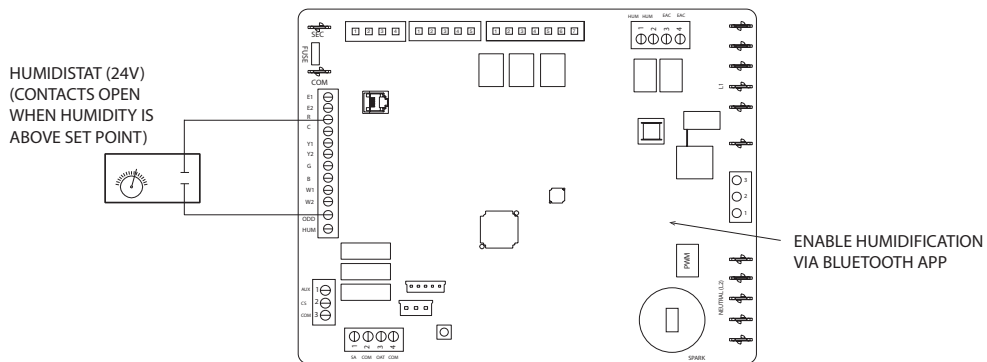

ST-A1325-07

INTEGRATED FURNACE CONTROL

HUMIDIFICATION/DEHUMIDIFICATION

C. HUMIDIFICATION AND DEHUMIDIFICATION CONTROL (REQUIRES OPTIONAL HUMIDIFIER)

C1. WITH COMMUNICATING THERMOSTAT 2-STAGE ONLY.

- To wire humidification and dehumidification, refer to section A1 and Figure 47A to wire humidifier.
- Jumper can be used between R and HUM STAT if humidification on every heat cycle is wanted. Without jumper, humidification is only enabled through communicating thermostat when humidification is required.
- Enable dehumidification through communicating thermostat. No additional wiring required to enable dehumidification.

C2. WITH NON-COMMUNICATING THERMOSTAT (REQUIRES OPTIONAL HUMIDISTAT)

- Dehumidification only and humidification can be accomplished by installing a humidistat as shown in figure 51 and 52. Requires dehumidification to be enabled via bluetooth app.
- Enabling dehumidification without the use of a humidistat is not advised. This will continuously reduce airflow by approx. 15%.

FIGURE 51
WIRING FOR HUMIDIFICATION (WITH OPTIONAL HUMIDISTAT AND HUMIDIFIER)
NOTE: FOR USE WITH NON-COMMUNICATING SYSTEMS. TWO STAGE ONLY

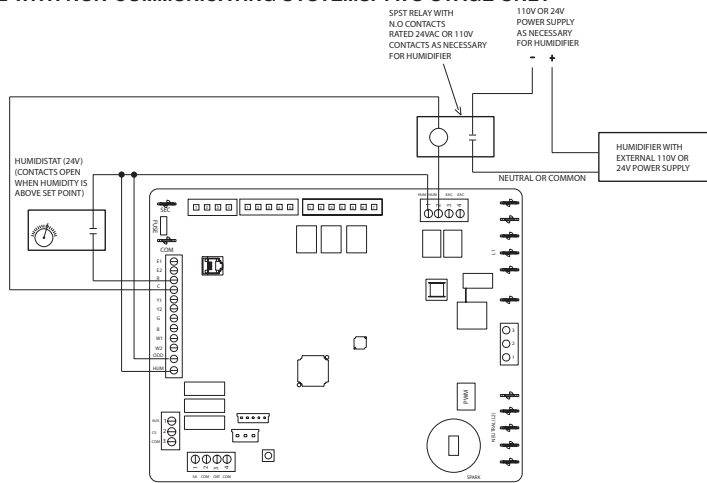
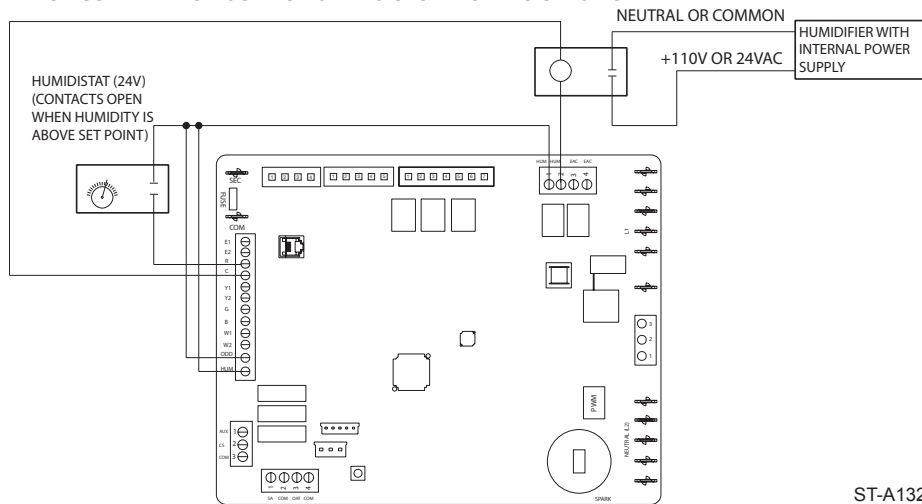

FIGURE 52
WIRING FOR HUMIDIFICATION WITH OPTIONAL HUMIDIFIER (HUMIDIFIER WITH INTERNAL POWER SUPPLY).
NOTE: FOR USE WITH NON-COMMUNICATING SYSTEMS. TWO STAGE ONLY.



INTEGRATED FURNACE CONTROL

MODEL DATA & TROUBLESHOOTING

Model data is loaded to the control board directly from the factory. If a furnace control replacement is required, model data will have to be loaded to the new control via Bluetooth. This is done using the contractor app and your smart-phone. Follow instructions that come with the replacement for proper programming procedure.

Additionally a blinking light is provided for fault code identification but detailed faults and troubleshooting should be viewed on your smart-phone via Bluetooth connection.

1. The alarm LED will flash the fault code number digit by digit.
2. There will be a 3 second delay between flashing each digit.
3. To flash a digit, the LED will blink (1 sec ON, 1 sec OFF) as many times as the numerical value of the digit.
4. To flash a zero digit, the LED will blink fast three times (0.2 sec ON, 0.2 sec OFF).
5. The control will delay for 10 sec before flashing the fault code again.
6. The control will flash the fault code that is most recent in the fault buffer. If a new fault enters the buffer when a flash sequence has started, the control will complete the sequence before moving to the most recent fault in the buffer.
7. The sequence will repeat until the fault buffer is empty.

INTEGRATED FURNACE CONTROL

FAULT CODES FOR 2 STAGE AND SINGLE STAGE



NOTE:

The contractor application will display current fault codes and provide troubleshooting information directly to your smart-phone. Download the contractor app by scanning the QR code on the gas furnace or in the Installation instruction booklet.

Fault Code	Fault Description
A001 F	Model Data Configuration Error
A002 F	Blower Coefficient Configuration Error
A011 F	Failed Ignition
T013 F	Flame Lost after Established
A013 F	Flame Lost after Established
A014 F	Flame Present with Gas Valve Off
T022 F	Main Limit Switch Open
A022 F	Main Limit Switch Open
A031 F	Open Fuse
A033 F	Roll-Out Switch Alarm
A044 F	Inducer Lo Pressure Switch Won't Open
T045 F	Inducer Lo Pressure Switch Won't Close
T047 F	Inducer Fan 5 Minute Lockout
A047 F	Inducer Fan 5 Minute Lockout
*T055 F	Inducer Hi Pressure Switch Won't Open
*A055 F	Inducer Hi Pressure Switch Won't Open
*T057 F	Inducer Hi Pressure Switch Won't Close
A058 F	Water Circuit Open
T059 F	Water Sensed
A059 F	Water Sensed
A061 F	Blower Fault - Motor Cannot Run
T081 F	Return Air Sensor Fault
*T082 F	Supply Air Sensor Fault
*T084 F	Outdoor Air Sensor Fault
*T085 F	Suction Line Temp Thermistor Failure
*T086 F	Suction Pressure Sensor Failure
T087 F	Power Board Temp Sensor Fault
*T088 F	EXV Sensor Measurement Error
A093 F	Internal Control Fault Detected
A111 F	One-hour Lockout: Main Limit Switch
A112 F	One-hour Lockout: Water Sense
A113 F	One-hour Lockout: Ignition Failure
A114 F	One-hour Lockout: Flame Lost Failure
A115 F	One-hour Lockout: Gas Valve Stuck Closed
A116 F	One-hour Lockout: Flame Presence Alarm
T117 F	Detect RPM Motor Failure
A117 F	Detect RPM Motor Failure
A126 F	Flame not Sensed with Gas Valve On - UL
A127 F	Flame Present with Gas Valve Off - UL
A221 F	Configuration Data Restore Failure
A222 F	Model Data Restore Failure
A223 F	Internal Fault: Monitor Chip Comm Failure
A224 F	Flame Status Circuit Failure
A225 F	Internal Fault: Gas Vlv 1 Rly Welded Shut
A226 F	Internal Fault: Gas Vlv 1 Rly Stuck Open
*A227 F	Internal Fault: Gas Vlv 2 Rly Welded Shut
*A228 F	Internal Fault: Gas Vlv 2 Rly Stuck Open
*TWO STAGE ONLY FAULT	

INTEGRATED FURNACE CONTROL

SUPPLY & OUTDOOR AIR TEMPERATURE SENSORS (TWO STAGE ONLY)

7. SUPPLY AND OUTDOOR AIR TEMPERATURE SENSOR INPUTS

Optional field installed supply air and outdoor air sensors (10K NTC thermistor) shall be read from the screw terminal block.

Control to resolve temperature within $\pm 2^{\circ}\text{F}$ at 70°F

There is to be an automatic detection of the supply and outdoor air sensors. If the resistance between the terminals is within a valid 10K thermistor range (supply air temp range = -40°F to 200°F , outdoor air temp range = -40 to 200°F), both sensors temperatures will be accessible.

If the resistance between the supply air terminals is determined to be out of range to a high resistance, it shall be interpreted as an uninstalled supplied air sensor and shall not cause an error condition unless a valid thermistor value was previously sensed on the same power cycle. If the sensor was determined to be present and then is opened the control will report a fault code. The app will report a fault code for 3 minutes and will not inhibit furnace operation. Also, if the resistance between the terminals is determined to be out of range to a low resistance and a valid thermistor value was sensed on the same power cycle, a fault code will be reported.

If the resistance between the outdoor air terminals (OAT) is determined to be out of range to a high resistance, it shall be interpreted as an uninstalled supplied outdoor air sensor and shall not cause an error condition unless a valid thermistor value was previously sensed on the same power cycle. If the sensor was determined to be present and then is opened the control should display a fault code. A fault code will be reported via bluetooth app and will not inhibit furnace operation.

Also, if the resistance between the terminals on the OAT is determined to be out of range to a low resistance, a fault code is to be display via Bluetooth app only if a valid thermistor value was previously sensed on the same power cycle.

Fault codes shall be only present for three minutes after the fault is detected. After three minutes has expired, the fault will no longer be set even if the condition creating the fault is still present. These faults are also only logged into the fault buffer one time. Should the sensor error later clear and then appear again the same sequence as noted previously will be repeated.

FIGURE 53
WIRING OF SUPPLY AIR (SA) AND OUTDOOR AIR (OAT) TEMPERATURE SENSORS. TWO STAGE ONLY.

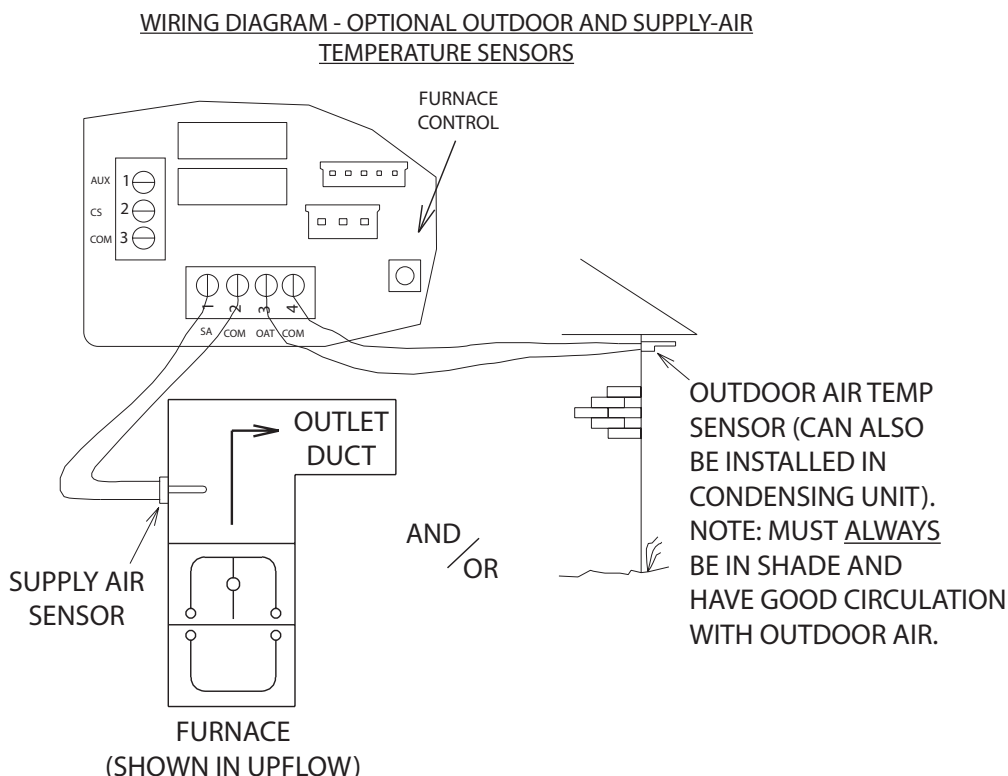

ST-A1325-08

INTEGRATED FURNACE CONTROL

AUXILIARY INPUTS

8. AUXILIARY INPUTS (COMMUNICATING SYSTEMS ONLY) (SEE FIGURE 54)

AUX inputs are provided for field installation of up to two auxiliary switches. The auxiliary inputs shall be used for smoke detectors, freeze switches, etc. The inputs are to be labeled **CS (Condensate Switches)**. CS input shall be used to provide a mean of using traditional drain pan switches. One or both inputs can be configured at the communicating thermostat as either

normally-opened or normally closed contacts. System operation when the contacts either open or close can be configured at the communicating thermostat.

A resistance of greater than 1k ohms to common shall be detected as an open switch and a resistance of less than 100 ohms shall be recognized as a closed switch.

FIGURE 54
WIRING OF AUXILIARY INPUTS (USE WITH COMMUNICATING SYSTEMS ONLY).

WIRING DIAGRAM - OPTIONAL AUXILIARY INPUTS

NOTE: AUXILLIARY INPUTS ARE ONLY MONITORED IN COMMUNICATING MODE.

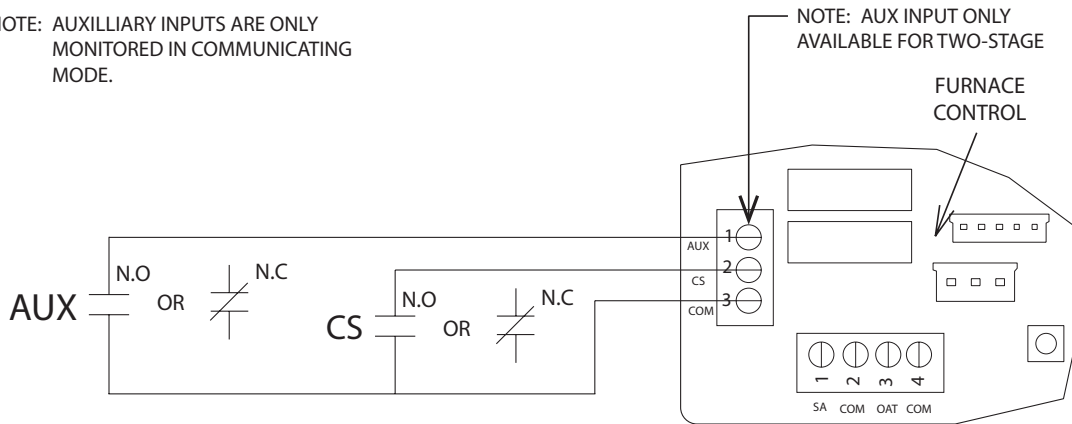

NOTE: AUX INPUT ONLY AVAILABLE FOR TWO-STAGE

NOTE: EITHER A NORMALLY-OPENED (N.O) OR NORMALLY-CLOSED (N.C) ACCESSORY CAN BE ATTACHED TO AUXILLIARY INPUT. SELECT CONFIGURATION (N.O OR N.C) AT THE COMMUNICATING THERMOSTAT.

ST-A1325-09

INTEGRATED FURNACE CONTROL

THERMOSTAT WIRING DIAGRAMS-COMMUNICATING

9. THERMOSTAT INPUTS (T1) – THERMOSTAT WIRING DIAGRAMS

Both communicating and legacy thermostats are to be connected at terminal block T1.

NOTE: When setting up an EcoNet thermostat, it is required to setup the outdoor unit through the thermostat. It must be identified as a communicating or non-communicating outdoor, and if it is single or multi-staged.

A. COMMUNICATING SYSTEMS

The furnace is capable of communicating with a thermostat and condenser to improve cooling and heat-pump airflow, displaying active faults and active furnace information at the thermostat and improved diagnostics and troubleshooting.

WIRING A FURNACE FOR COMMUNICATIONS.

Maximum wire lengths and notes about wiring communicating systems are noted below.

MAXIMUM COMMUNICATING WIRE LENGTHS (E1, E2, R & C)

Max Wire Length – Thermostat to Furnace = 125 FT @ 18 AWG*

Max Wire Length – Furnace to Condenser = 125 FT @ 18 AWG*

Max Wire Length – Between any 2 devices = 125 FT @ 18 AWG*

Sum Max Total Wire Length for All Components = 500 ft

(see Figure 53)

Notes:

1. Wires may be solid or stranded.
2. *Wire gage smaller than 18 AWG is not approved or recommended for this application.
3. If the thermostat wiring will be located near or in parallel with high voltage wiring, cable TV, Ethernet wiring, or radio frequency equipment, then shielded thermostat wire can be used to reduce or eliminate potential interference. The shielding must be contiguous (have continuity) across all devices and all wire segments. This should be done by twisting the shielding wires from adjacent segments together. Further, the shielding for the entire system must be grounded in a single location. Multiple grounds on the shielding system are NOT permitted. The shield wire should be connected to the C terminal, or ground, at the indoor unit. The shield wire should NOT be connected to any terminal at the Control Center (aka;Thermostat). Connecting the shield to ground at both ends can cause current loops in the shield, reducing shield effectiveness.
4. When using existing wire from a previous installation, be sure to trim the tip of the wire back past the insulation and strip a small amount of insulation from the wire to expose clean new copper for the communicating connections. Fresh copper must be exposed when making the communicating connections or communications may not be properly established.

FIGURE 55
WIRING DIAGRAM FOR A FULLY COMMUNICATING SYSTEM.

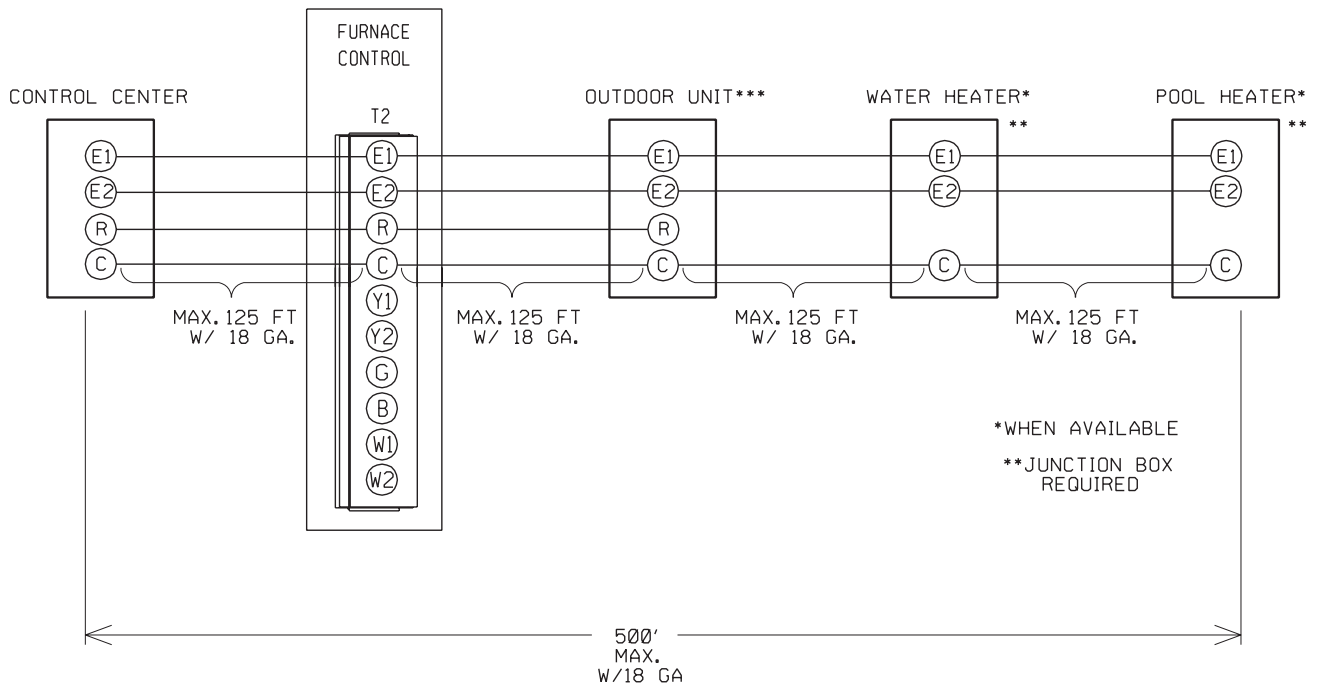

THIS IS THE ONLY APPROVED CONFIGURATION

ST-A1325-10

INTEGRATED FURNACE CONTROL

THERMOSTAT WIRING DIAGRAMS-CONDENSING UNIT (NON-COMMUNICATING)

A. WIRING OF FULLY COMMUNICATING SYSTEMS.

Figure 55 is the wiring diagram for connecting the furnace to an approved EcoNet communicating thermostat and approved EcoNet communicating condenser. The only approved configuration is to install dedicated wires directly from the furnace to the thermostat and a separate set of dedicated wires directly from the furnace to the condenser.

Additional EcoNet devices can be added to the system as shown in Figure 55. The approved wiring

configuration is the daisy-chain configuration shown in Figure 55. A star wiring configuration is not approved and should not be used.

Note: The only approved configuration requires that four dedicated wires (E1, E2, R and C) be installed from the furnace to the condenser.

B. SPECIAL CONFIGURATION – wiring of non communicating condenser units with communicating furnace and thermostat (See Figure 56).

FIGURE 56
WIRING DIAGRAM FOR NON-COMMUNICATING CONDENSER UNIT WITH COMMUNICATING FURNACE AND THERMOSTAT.

A. WIRING DIAGRAM

SPECIAL CONFIGURATION:
COMMUNICATING THERMOSTAT AND FURNACE
WITH NON-COMMUNICATING CONDENSER
(SINGLE - STAGE ONLY CONDENSER)

125 FEET MAX. @ 18 GA.

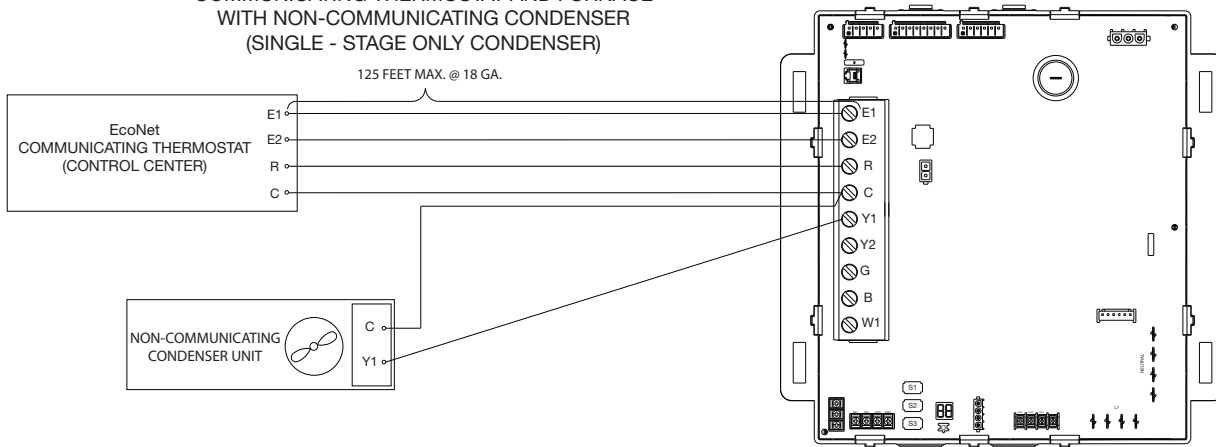

B. WIRING DIAGRAM

SPECIAL CONFIGURATION:
COMMUNICATING THERMOSTAT AND FURNACE
WITH NON-COMMUNICATING CONDENSER
(TWO - STAGE ONLY CONDENSER)

125 FEET MAX. @ 18 GA.

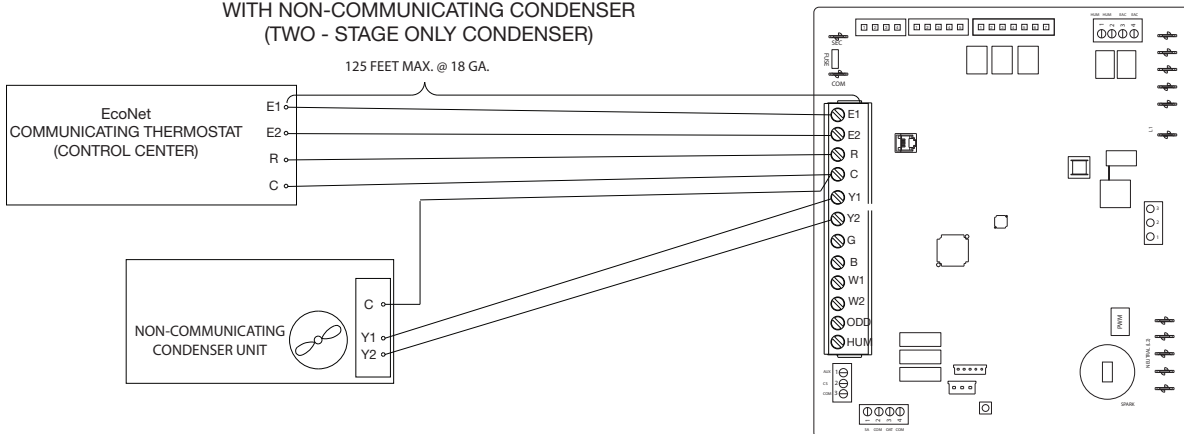

ST-A1325-11

INTEGRATED FURNACE CONTROL

THERMOSTAT WIRING DIAGRAMS-CONDENSING UNIT (NON-COMMUNICATING)

C. CONDENSING SYSTEMS WITH LEGACY THERMOSTATS

C1. Wiring of a single-stage legacy thermostat with autostaging selected (See Figure 57).

C2. Wiring of a two-stage legacy thermostat (See Figure 58).

FIGURE 57
WIRING DIAGRAM FOR A LEGACY SINGLE-STAGE THERMOSTAT WITH AUTOSTAGING.

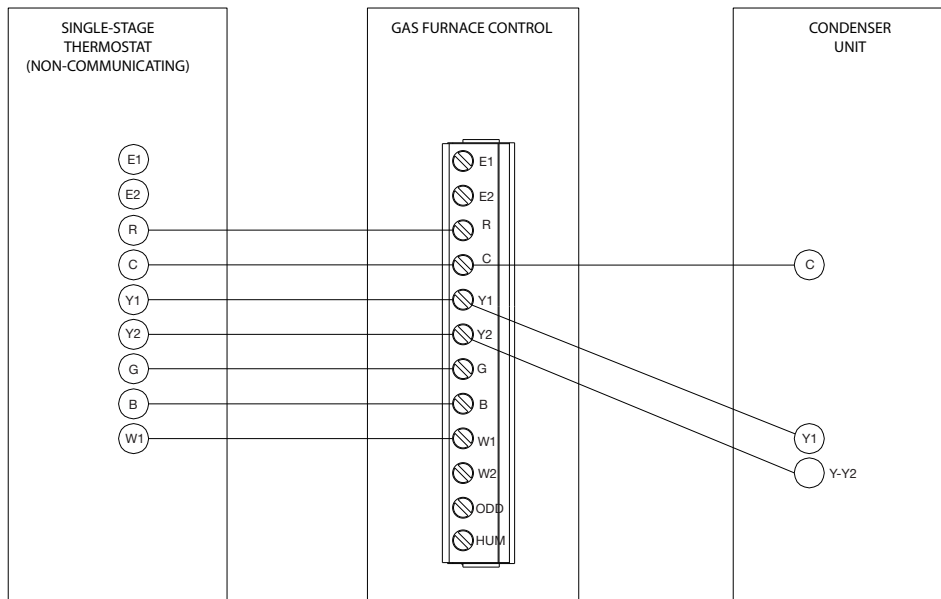

NOTE: 1.) SELECTIONS FOR TIME STAGING CAN BE MADE VIA CONTRACTOR APP WHEN CONNECTED WITH BLUETOOTH.

2.) FOR SINGLE STAGE COOLING A JUMPER BETWEEN Y1 AND Y2 IS REQUIRED.

ST-A1325-12

INTEGRATED FURNACE CONTROL

THERMOSTAT WIRING DIAGRAMS-CONDENSING UNIT (NON-COMMUNICATING)

FIGURE 58
WIRING DIAGRAM FOR A LEGACY 2-STAGE THERMOSTAT.

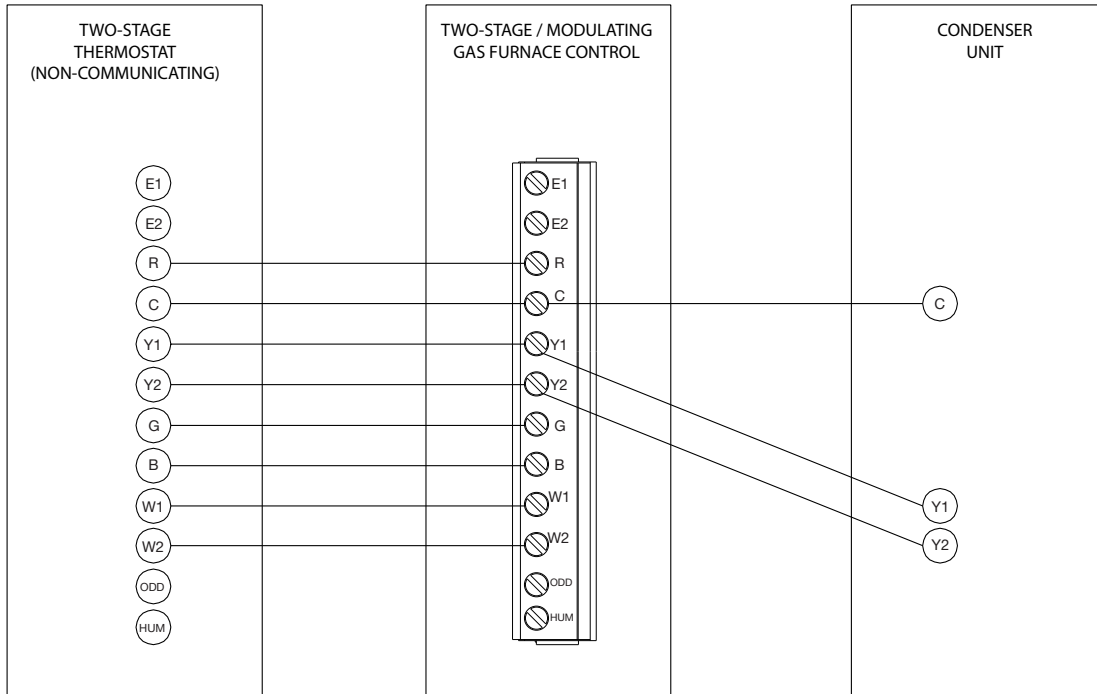

ST-A1325-13

INTEGRATED FURNACE CONTROL

THERMOSTAT WIRING DIAGRAMS-HEAT PUMP (NON-COMMUNICATING)

- D. SPECIAL CONFIGURATION – wiring of non communicating heat-pumps with communicating furnace and thermostaT (See Figure 59).

FIGURE 59
WIRING DIAGRAM FOR NON-COMMUNICATING HEAT PUMPS WITH COMMUNICATING FURNACE AND THERMOSTAT

A. WIRING DIAGRAM

SPECIAL CONFIGURATION:
COMMUNICATING THERMOSTAT AND FURNACE
WITH NON-COMMUNICATING HEAT PUMP
(SINGLE - STAGE ONLY)

125 FEET MAX. @ 18 GA.

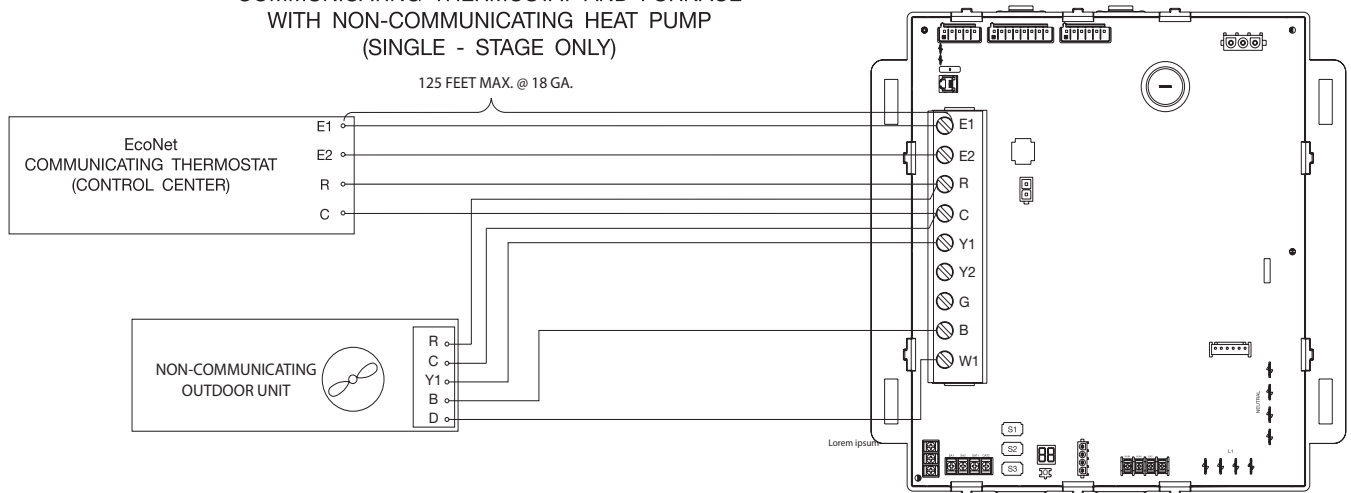

B. WIRING DIAGRAM

SPECIAL CONFIGURATION:
COMMUNICATING THERMOSTAT AND FURNACE
WITH NON-COMMUNICATING HEAT PUMP
(TWO - STAGE ONLY)

125 FEET MAX. @ 18 GA.

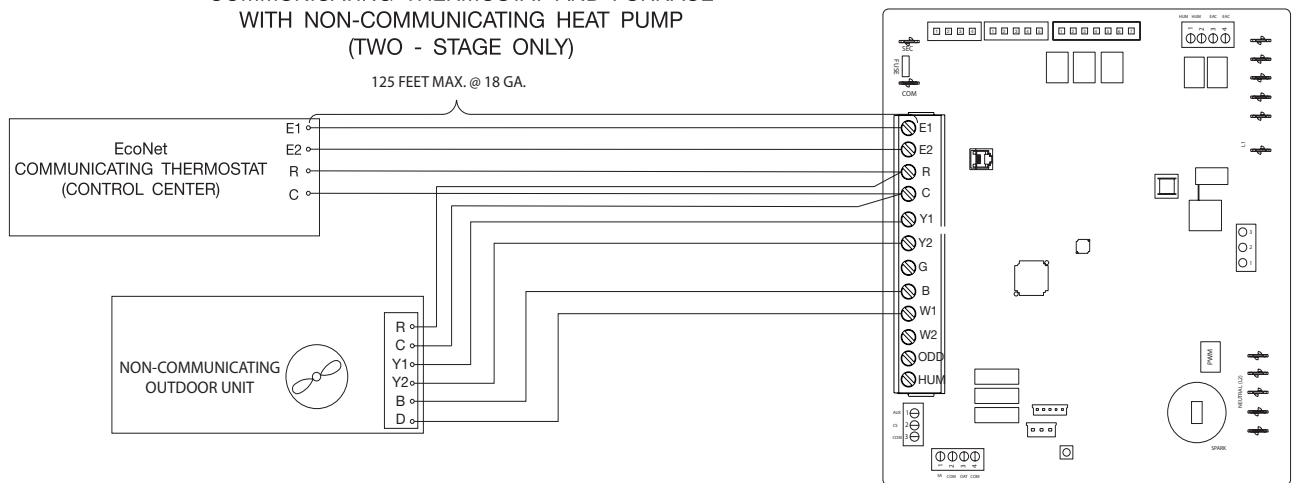

ST-A1325-14

INTEGRATED FURNACE CONTROL

THERMOSTAT WIRING DIAGRAMS-HEAT PUMP (NON-COMMUNICATING)

E. HEAT PUMP SYSTEMS WITH LEGACY THERMOSTATS

E1. Wiring of a single-stage legacy thermostat with autostaging selected (See Figure 60).

E2. Wiring of a two-stage legacy thermostat (See Figures 61a).

FIGURE 60
WIRING DIAGRAM FOR A LEGACY SINGLE-STAGE THERMOSTAT WITH AUTOSTAGING.

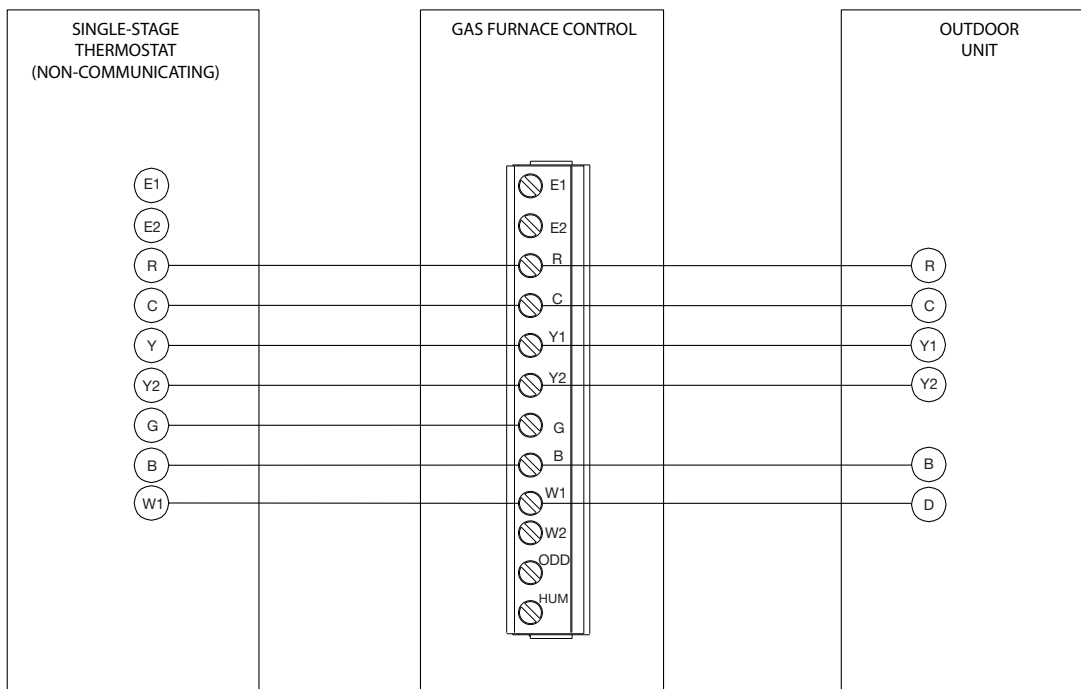

NOTE: 1.) SELECTIONS FOR TIME STAGING CAN BE MADE VIA CONTRACTOR APP WHEN CONNECTED WITH BLUETOOTH.

2.) FOR SINGLE STAGE COOLING A JUMPER BETWEEN Y1 AND Y2 IS REQUIRED.

ST-A1325-15

INTEGRATED FURNACE CONTROL

THERMOSTAT WIRING DIAGRAMS-HEAT PUMP (NON-COMMUNICATING)

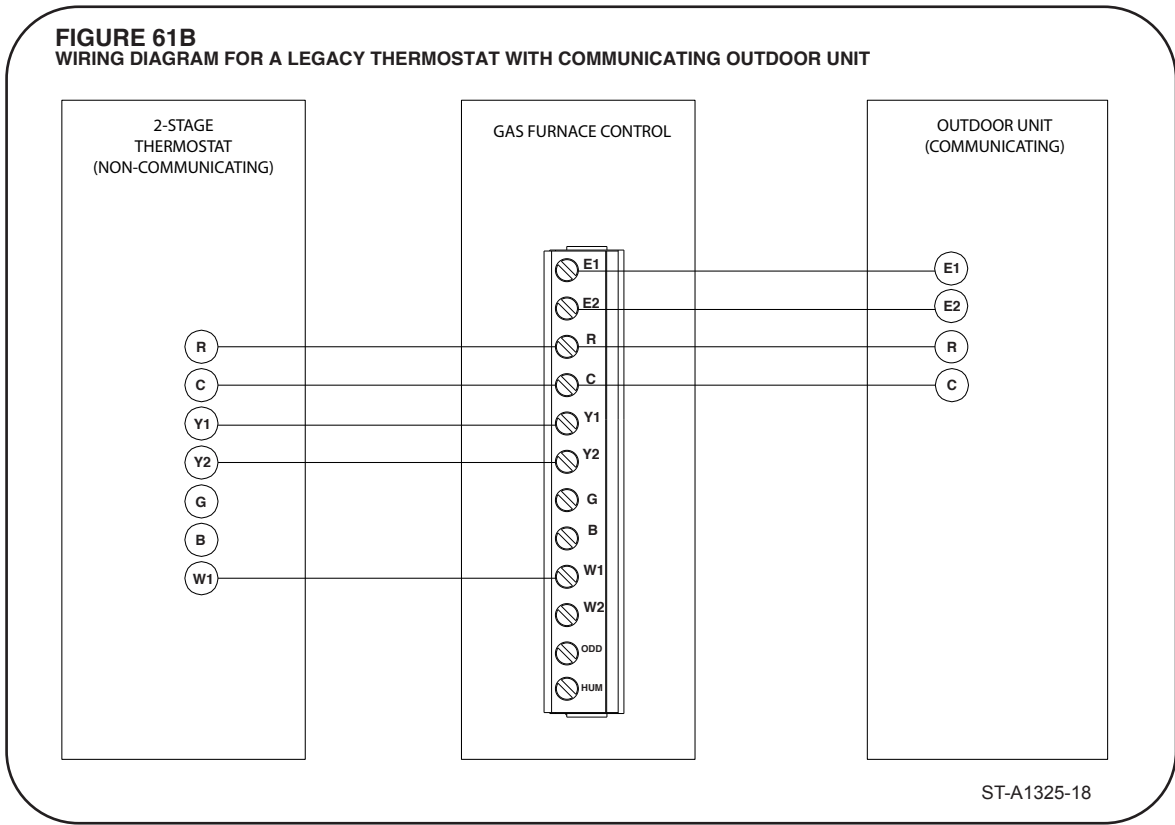
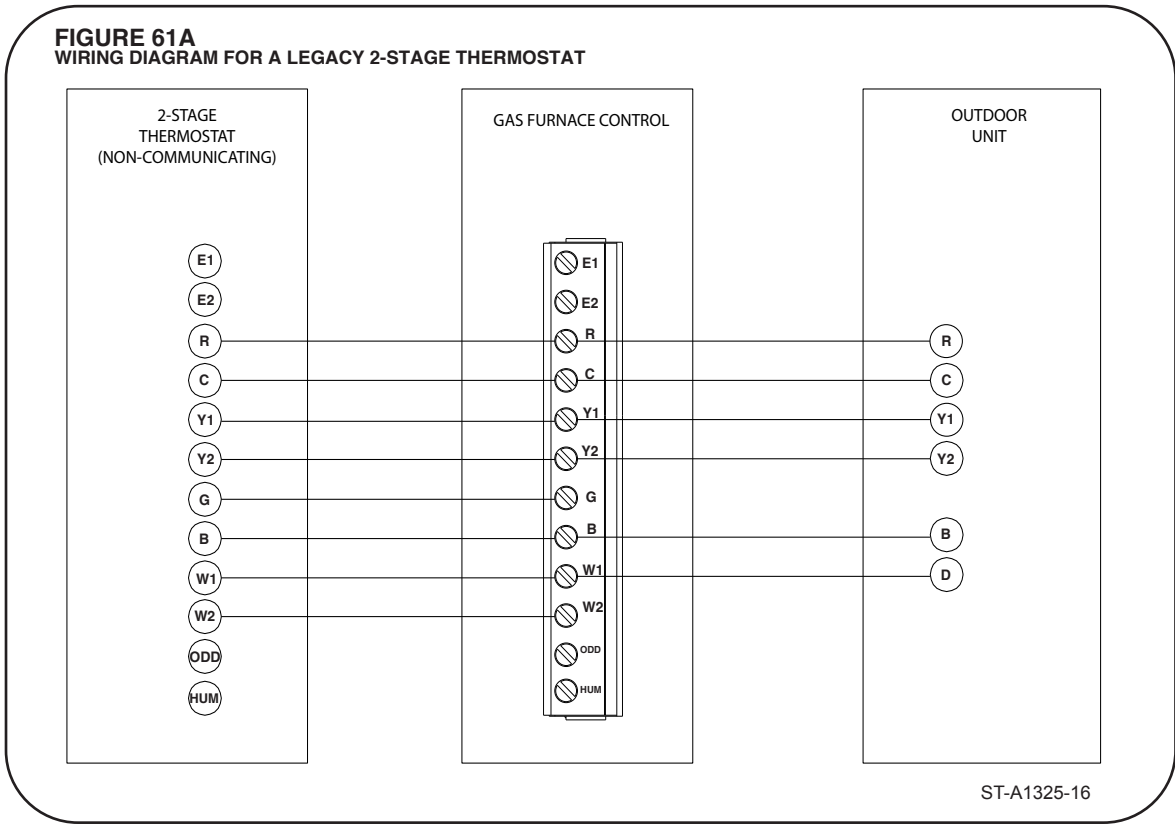

TIMING DIAGRAM AND FIELD ADJUSTMENTS

TIMING DIAGRAM

Field Selections

TABLE 17
TIMING DIAGRAM

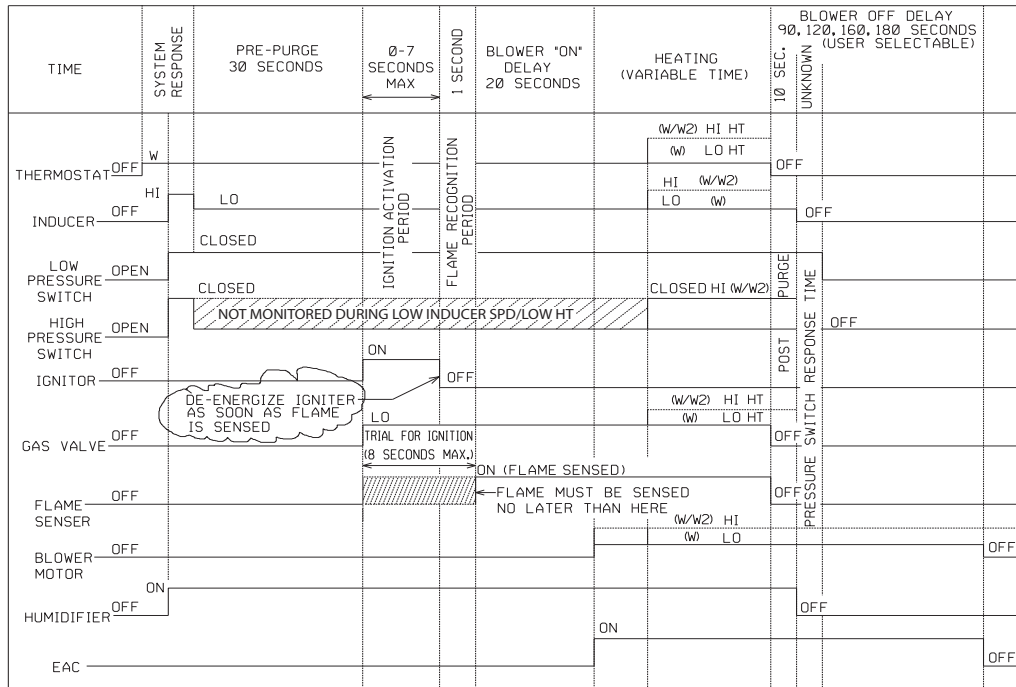

ST-A1205-10-X0

ST-A1205-10.S1-00

ADJUSTING OR CHECKING FURNACE INPUT

The maximum gas supply pressure to the furnace should be 10.5" w.c. for natural gas and 13.0" w.c. for L.P. The minimum gas supply pressure for purposes of input adjustment to the furnace should be 5" w.c. for natural gas and 11" w.c. for L.P.

A calibrated manometer is required for accurate gas pressure readings.

The manifold pressure should be set at 3.5" w.c. high fire, 1.8" low fire, for natural gas and 10" w.c. high fire and 4.9" w.c. low fire for L.P. Only small variations in the gas flow should be made by means of the pressure regulator adjustment. In no case should the final manifold pressure vary more than plus or minus 0.3" w.c. from the above-specified pressures. To adjust the pressure regulator, remove the regulator cap and turn the adjustment screw clockwise to increase pressure or counterclockwise to decrease pressure. Then replace the regulator cap securely. Any necessary major changes in the gas flow rate should be made by changing the size of the burner orifices.

To change orifice spuds, shut off the manual gas valve and remove the gas manifold. On LP gas furnaces, the LP gas supply pressure must be set between 11" and 13" w.c. by means of the tank or branch supply regulators. The furnace manifold pressure should be set at 10" w.c. at the gas control valve. For elevations up to 2,000 feet, rating plate input ratings apply. For high altitudes (elevations over 2,000 ft.), see conversion kit index for derating and orifice spud sizes.

Checking furnace input is important to prevent over firing beyond its design-rated input. NEVER SET INPUT ABOVE THAT SHOWN ON THE RATING PLATE. Use the following table or formula to determine input rate. Start the furnace and measure the time required to burn one cubic foot of gas. Prior to checking the furnace input, make certain that all other gas appliances are shut off, with the exception of pilot burners. Time the meter with only the furnace in operation.

FIELD ADJUSTMENTS

BLUETOOTH SETUP

NOTE: For systems that are NOT fully communicating, Bluetooth connection and the contractor app will be required for proper airflow selections. Locate the QR Code on the exterior of the furnace and download the contractor app.



1. Outdoor Unit Stages:

Select the Outdoor unit number of stages. If it is connected to a single stage Outdoor unit, select 1. If the furnace is connected to a two stage Outdoor unit, select 2.

2. Outdoor Unit Tonnage:

Select the Outdoor unit size. A higher tonnage means the outdoor unit has a bigger capacity.

3. Airflow Trim:

Select airflow trim percent will increase performance either on cooling or heating.

4. High Gas Heat Rise:

Factory Setting = Value Specified on Rating Label.

Side return = Recalibrates motor for side return.

Approx. +7°F = Decreases Airflow by approximately 13% to achieve approximately +7°F temperature-rise.

Approx. +12°F = Decrease Airflow by approximately 20% to achieve approximately +12°F temperature-rise.

5. Low Gas Heat Rise:

Factory Setting = Value Specified on Rating Label.

Side return = Recalibrates motor for side return.

Approx. +7°F = Decrease airflow by approximately 16% to achieve approximately +7°F temperature-rise.

Approx. +12°F = Decrease airflow by approximately 24% to achieve approximately +12°F temperature-rise.

6. EXV Superheat Setpoint. (this only shows up if the control board shows the EXV input is enabled):

EXV uses inputs from suction line thermistor and suction pressure transducer to precisely calculate suction superheat and makes necessary adjustments to the refrigerant flow through the EXV to maintain the optimum superheat level. The setpoint is the most efficient setpoint for each coil as the factory default, however, a range is provided to further optimize for different installations.

7. HP/ Cooler Blower Off Delay:

This is the time that the blower would keep engaged after a heat pump or a cooling call is removed.

8. Thermostat Heat Stage Type:

Select 1 if wiring to a single stage thermostat. Select two if wiring to a two-stage thermostat.

9. High Stage Heating Timer (This only shows in the app if single stage thermostat is set):

With a single stage thermostats, upon a heating call (24 VAC W1 signal), this will set the time on a low call before running into a high heat call.

10. On-Demand Dehumidification:

This will enable or disable dehumidification feature. Make sure On Demand Dehumidification is wired on the control board.

11. AC Blower Airflow Reduction (This only shows if ODD is enabled above):

If On-Demand Dehumidification is enabled, this will allow a selection by percentage to reduce airflow while cooling to bring down indoor humidity. Please note, if -10% airflow trim was selected above, this will cause more reduction.

FIELD ADJUSTMENTS

TABLE 18
METER TIME

METER TIME IN MINUTES AND SECONDS FOR NORMAL INPUT RATING OF FURNACES EQUIPPED FOR NATURAL GAS OR L.P.											
INPUT (BTU/HR)	METER SIZE (FT ³ /REV)	HEATING VALUE OF GAS (BTU/FT ³)									
		900		1000		1040		1100		2500	
		MIN	SEC	MIN	SEC	MIN	SEC	MIN	SEC	MIN	SEC
42,000	ONE	1	17	1	26	1	29	1	34	3	34
	TEN	12	51	14	17	14	51	15	43	35	43
56,000	ONE	0	58	1	4	1	7	1	11	2	41
	TEN	9	39	10	43	11	9	11	47	26	47
70,000	ONE	0	46	0	51	0	53	0	57	2	9
	TEN	7	43	8	34	8	55	9	26	21	26
84,000	ONE	0	39	0	43	0	45	0	47	1	47
	TEN	6	26	7	9	7	26	7	51	17	51
98,000	ONE	0	33	0	37	0	38	0	40	1	32
	TEN	5	31	6	7	6	22	6	44	15	18
112,000	ONE	0	29	0	32	0	33	0	35	1	20
	TEN	4	49	5	21	5	34	5	54	13	24

Formula: Input BTU/HR = $\frac{\text{Heating Value of Gas (BTU/ft}^3) \times 3600 \times \text{correction factor}}{\text{Time (in seconds) for 1 cubic ft of Gas}}$

Field Selections

SETTING INPUT RATE

The furnace is shipped from the factory with #51 orifices. They are sized for natural gas having a heating value of 1100 BTU/cu. ft. and a specific gravity of .60.

Since heating values vary geo-graphically, the manifold pressure and/or gas orifice size may need to be changed to adjust the furnace to its nameplate input. Consult the

local gas utility to obtain the yearly average heating value and orifice size required to fire each individual burner at 14,000 BTU/HR.

NOTE: Refer to the High Altitude Section of this manual and the National Fuel Gas Code for high altitude rate adjustment above 2,000 ft.

AIR FLOW

The importance of proper air flow over the heat exchanger cannot be over emphasized.

NOTE: Where the maximum airflow is expected to be over 1800 CFM, BOTH sides or the bottom must be used for the return air.

▲ CAUTION

IT IS IMPORTANT THAT EACH DUCT SYSTEM BE SIZED AND INSTALLED FOR THE SPECIFIC APPLICATION BY PROPERLY APPLYING THE APPROPRIATE INDUSTRY ACCEPTED STANDARD. IF LESS THAN MINIMUM STANDARDS ARE APPLIED, THE EQUIPMENT USER COULD EXPECT TO EXPERIENCE HIGHER UTILITY BILLS, MAJOR COMPONENT FAILURE, VARYING DEGREES OF AIR NOISE OR OTHER UNSATISFACTORY ISSUES, OVER WHICH THE MANUFACTURER HAS NO CONTROL.

TEMPERATURE RISE CHECK

To determine if the air flow is correct, make a temperature rise check.

1. Insert a thermometer in the supply air duct as close to the furnace as possible yet out of a direct line from the heat exchanger. See Figure 62.
2. Insert a thermometer in the return air duct as close to the furnace as possible.
3. Operate the furnace for a minimum of 15 minutes in gas heat mode.
4. When the thermometer in the supply air duct stops rising (approximately five minutes), subtract the return air temperature from the supply air temperature. The difference is the temperature rise.

5. Compare the measured temperature rise to the approved temperature rise range listed on the furnace name plate.

Furnaces with constant CFM blowers will automatically adjust blower speed to meet the CFM demanded if the external static pressure is within the listed range of the furnace. If airflow adjustment is necessary, use the trim selections in the communicating thermostat or the Bluetooth contractor app for legacy installations. If after adjustment you are still above nameplate range, your duct system may be too restrictive due to undersized ducts.

▲ WARNING

THE MEASURED TEMPERATURE RISE MUST BE WITHIN THE TEMPERATURE RISE RANGE SPECIFIED ON THE RATING PLATE. OPERATING THE UNIT WITH A RISE OUTSIDE THE STATED RANGE COULD CAUSE DAMAGE TO THE HEAT EXCHANGER OR INTERMITTENT OPERATION. THIS COULD CAUSE INJURY OR DEATH AND WILL VOID THE MANUFACTURER'S WARRANTY FOR THIS PRODUCT.

FIGURE 62
TEMPERATURE RISE MEASUREMENT



MAINTENANCE

MAINTENANCE

WARNING

THESE INSTRUCTIONS ARE INTENDED AS AN AID TO QUALIFIED SERVICE PERSONNEL FOR PROPER INSTALLATION, ADJUSTMENT AND OPERATION OF THIS UNIT. READ THESE INSTRUCTIONS THOROUGHLY BEFORE ATTEMPTING INSTALLATION OR OPERATION. FAILURE TO FOLLOW THESE INSTRUCTIONS MAY RESULT IN IMPROPER INSTALLATION, ADJUSTMENT, SERVICE OR MAINTENANCE, POSSIBLY RESULTING

IN FIRE, ELECTRICAL SHOCK, CARBON MONOXIDE POISONING, EXPLOSION, PROPERTY DAMAGE, PERSONAL INJURY OR DEATH.

DISCONNECT MAIN ELECTRICAL POWER TO THE UNIT BEFORE ATTEMPTING ANY MAINTENANCE. FAILURE TO DO SO CAN CAUSE ELECTRICAL SHOCK RESULTING IN PERSONAL INJURY OR DEATH.

FILTERS

CAUTION

DO NOT OPERATE THE SYSTEM FOR EXTENDED PERIODS WITHOUT FILTERS. A PORTION OF THE DUST ENTRAINED IN THE AIR MAY TEMPORARILY LODGE IN THE AIR DUCT RUNS AND AT THE SUPPLY REGISTERS. ANY RECIRCULATED DUST

PARTICLES WILL BE HEATED AND CHARRED BY CONTACT WITH THE FURNACE HEAT EXCHANGER. THIS RESIDUE WILL SOIL CEILINGS, WALLS, DRAPES, CARPETS AND OTHER HOUSEHOLD ARTICLES.

LUBRICATION

IMPORTANT: DO NOT attempt to lubricate the bearings on the blower motor or the induced draft blower motor. Addition of lubricants can reduce the motor life and void the warranty.

The blower motor and induced draft blower motor are permanently lubricated by the manufacturer and do not require further attention.

It is recommended that the blower motor and induced draft blower motor be cleaned periodically by a qualified installer, service agency, or the gas supplier to prevent the possibility

of overheating due to an accumulation of dust and dirt on the windings or on the motor exterior. And, as suggested elsewhere in these instructions, the air filters should be kept clean. Dirty filters can restrict airflow. The motor depends upon sufficient air flowing across and through it to keep from overheating.

SYSTEM OPERATION INFORMATION

ADVISE THE CUSTOMER

1. Keep the air filters clean. The heating system will operate better, more efficiently and more economically.
2. Arrange the furniture and drapes so that the supply air registers and the return air grilles are unobstructed.
3. Close doors and windows. This will reduce the heating load on the system.
4. Avoid excessive use of kitchen exhaust fans.
5. Do not permit the heat generated by television, lamps or radios to influence the thermostat operation.
6. Except for the mounting platform, keep all combustible articles 3 feet from the furnace and vent system.
7. **IMPORTANT:** Replace all blower doors and compartment covers after servicing the furnace. Do not operate the unit without all panels and doors securely in place.
8. Explain the advantages of continuous fan operation to the customer.

ANNUAL INSPECTION

- The furnace should operate for many years without excessive scale build-up in the flue passageways. However, it is recommended that a qualified installer, service agency, or the gas supplier annually inspect the flue passageways, the vent system and the main burners for continued safe operation. Pay particular attention to deterioration from corrosion or other sources.
- **IMPORTANT:** It is recommended that at the beginning and at approximately half way through the heating season, a visual inspection be made of the main burner flames for the desired flame appearance by a qualified installer, service agency or the gas supplier. If the flames are distorted and/or there is evidence of back pressure, check the vent and inlet air system for blockage. If there is carbon and scale in the heat exchanger tubes, the heat exchanger assembly should be replaced.
- **IMPORTANT:** It is recommended that at the beginning of the heating season, the flame sensor be cleaned with fine steel wool or Scotch Bright Pad by a qualified installer, service agency or the gas supplier.
- **IMPORTANT:** It is recommended that at the beginning of the heating season, the condensate trap be inspected for debris or blockage. A blocked condensate trap can cause water to back up into the primary heat exchanger and lead to nuisance tripping of the overtemperature switches.
- **IMPORTANT:** It is recommended that at the beginning of the heating season, the condensate neutralizer if used be replaced by a qualified installer, service agency or the gas supplier.
- **IMPORTANT:** It is recommended that an annual inspection and cleaning of all furnace markings be made to assure legibility. Attach a replacement marking, which can be obtained through the distributor, if any are found to be illegible or missing.
- **IMPORTANT:** It is recommended that at the beginning of each heating season the flue couplings and hoses be checked for damage or water leakage. Hose couplings and clamps should be tight and free of cracks. Tighten and replace damaged components as necessary.

WARNING

HOLES IN THE VENT PIPE OR HEAT EXCHANGER CAN CAUSE TOXIC FUMES TO ENTER THE HOME, RESULTING IN CARBON MONOXIDE POISONING OR DEATH. THE VENT PIPE OR HEAT EXCHANGER MUST BE REPLACED IF THEY LEAK.

REPLACEMENT PARTS

Homeowners please visit www.rheem.com for product information.

Replacement parts division visit <http://www.rheemparts.com/Catalog/>



DIAGNOSTICS AND TROUBLESHOOTING

LOCKOUT AND REPLACING THE FURNACE CONTROL

All lockout conditions can be cleared immediately provided that the original fault causing the lockout is cleared and power to the unit is cycled off and then back on again.

The furnace control will not initiate a heat cycle during any lockout condition. A call for compressor or continuous fan will generally be responded to.

FIVE-MINUTE LOCKOUT

A five minute “soft” lockout will be initiated if the low pressure switch fails to close after 60 seconds of continuous inducer operation at the beginning of a normal heat cycle (pressure switch proving period).

ONE-HOUR LOCKOUT

A one hour “soft” lock out will be initiated when:

- Flame has not been detected after four ignition trials.
- Flame has been lost for five times in one heat call.
- Undesired flame has been detected. The one-hour period will commence after flame is no longer detected.
- Dead Blower has been detected (main limit circuit open for more than 150 seconds)
- When voltage has unexpectedly been detected on the gas valve circuit and voltage goes away when inducer is shut off.
- If a *Water Sensed* condition is detected once during heat call (heat cycle terminated in response to fault) and then clears and then is detected again within 5 minutes of the next heat attempt (same heat call).

HARD LOCKOUT

Three conditions shall cause a hard lockout:

1. The control senses an unspecified internal fault. Fault code “**93**” is set.
2. Voltage is detected unexpectedly on the gas valve contacts (welded relay) and will not clear by cycling the inducer . Fault code “**93**” is set.
3. The furnace control will declare that the blower motor is inoperable (dead) if the main limit control has been open for more than 150 seconds. Gas heating is terminated. However, the control continues to try to operate heating for up to four attempts in case the blower motor starts working again. If a dead blower has been declared four times in one heat call, the furnace control enters a hard-lockout. Fault code “**61**” is set.

REPLACING THE FURNACE CONTROL

The model data must be written to the replacement control using Bluetooth. First, the contractor app must be fully installed by scanning the QR code on the furnace. Next, make sure doors are in place and power up furnace before Bluetooth connection can be made.

TROUBLESHOOTING SECTION

IGNITER LOCATION

The igniter location is critical to furnace operation. If the igniter is ever replaced always pay attention to the electrodes of the igniter to verify they are properly gapped. The gap should be .110" (2.79mm) between the electrodes.

Once the gap is properly verified and installed the location of the gap must be in the proper location in relation to the burner for best performance. See Figure 63 for igniter location.

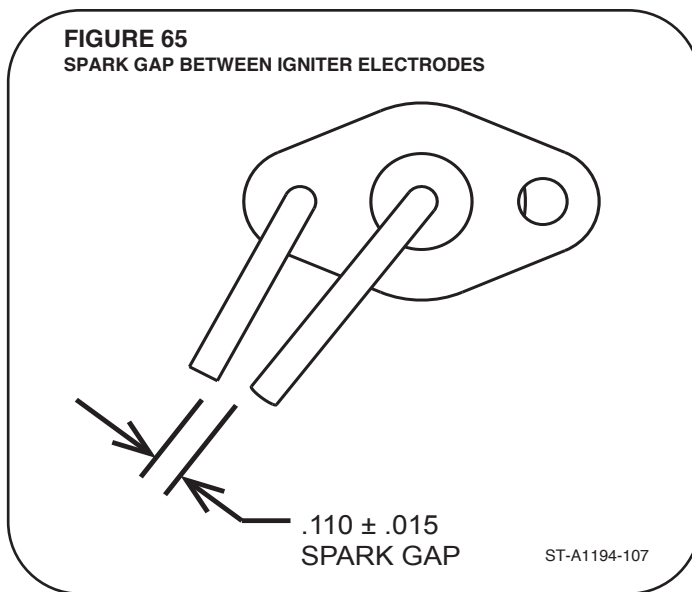
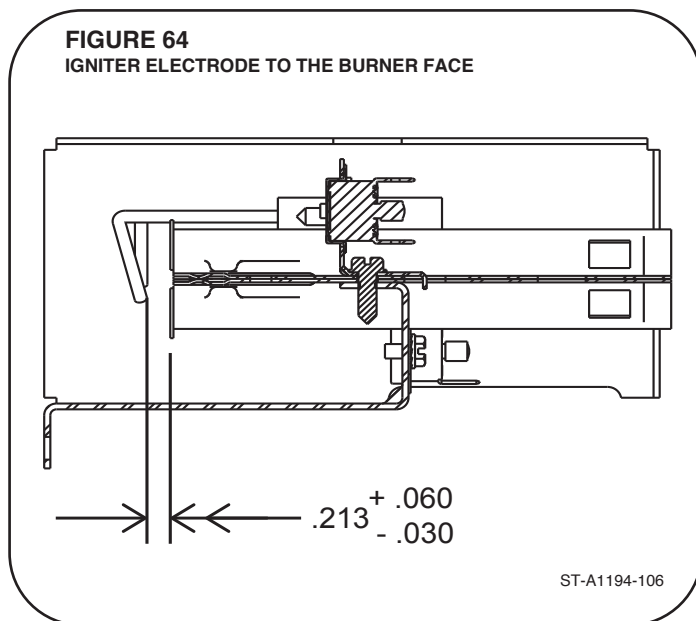
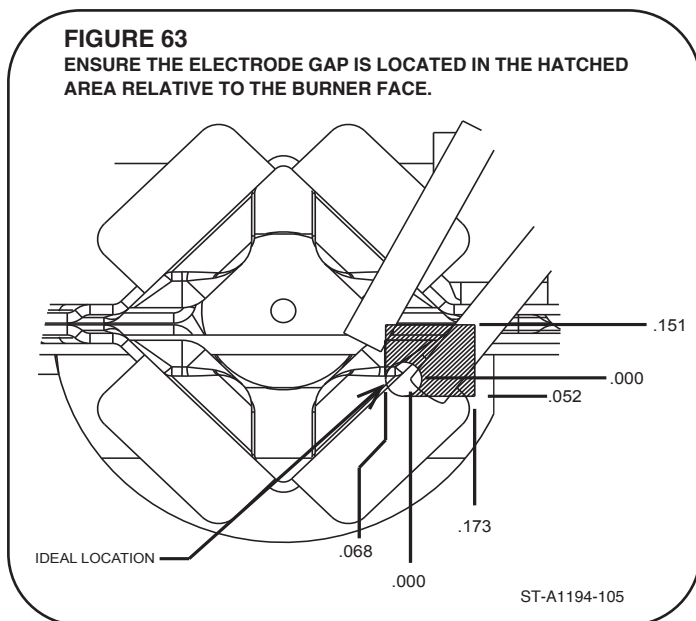

WIRING DIAGRAM

WIRING DIAGRAM

Figure 66 is a complete wiring diagram for the furnace

A wiring diagram is also available on the unit.

FIGURE 66
2-STAGE FURNACE WIRING DIAGRAM

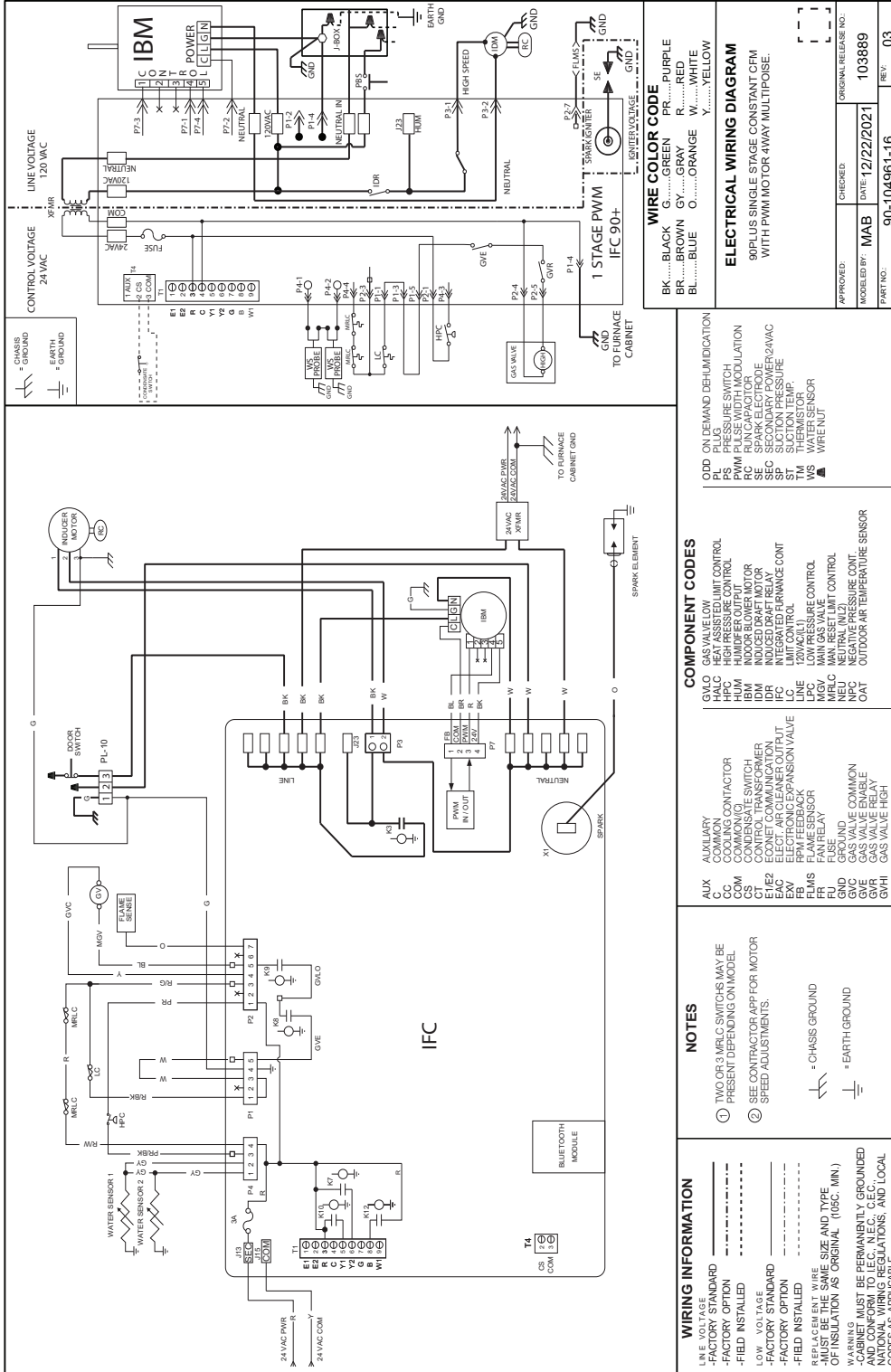

WIRE COLOR CODE	
BK.....BLACK	G.....GREEN
BR.....BROWN	GY.....GRAY
BL.....BLUE	O.....ORANGE
	PR.....PURPLE
	R.....RED
	W.....WHITE
	Y.....YELLOW

ELECTRICAL WIRING DIAGRAM	
90 PLUS SINGLE STAGE CONSTANT CFM WITH PWM MOTOR 4WAY MULTIPULSE.	
APPROVED:	CHECKED:
MODELED BY: MAB	DATE: 12/22/2021
PART NO.:	90-104961-16
REV.:	03

COMPONENT CODES	
GMLO	GAS VALVE LIMIT CONTROL
HFC	HIGH PRESSURE CONTROL
HJM	HUMIDIFIER OUTPUT
ICM	INDUCER MOTOR
IDM	INDUCED DRAFT MOTOR
IFC	INTEGRATED FURNACE CONT.
IR	INDUCER RELAY
LC	LINE
LPC	LOW PRESSURE CONTROL
MLC	MAN RESET LIMIT CONTROL
NIC	NEGATIVE PRESSURE CONT.
NT	OUTDOOR AIR TEMPERATURE SENSOR
OAT	

NOTES	
1	TWO OR MORE MRLC SWITCHES MAY BE PRESENT DEPENDING ON MODEL.
2	SEE CONTRACTOR APP FOR MOTOR SPEED ADJUSTMENTS.
<p> * CHASSIS GROUND * EARTH GROUND </p>	

WIRING INFORMATION	
LINE VOLTAGE	-----
-FACTORY STANDARD	-----
-FIELD INSTALLED	-----
LOW VOLTAGE	-----
-FACTORY STANDARD	-----
-FIELD INSTALLED	-----
REPLACEMENT WIRE	-----
-MUST BE THE SAME SIZE AND TYPE OF INSULATION AS ORIGINAL (105C. MIN.)	-----
-CABINET MUST BE PERMANENTLY GROUNDED AND CONFORM TO I.E.C., N.E.C., C.E.C., NATIONAL WIRING REGULATIONS, AND LOCAL CODES AS APPLICABLE	-----

WIRING DIAGRAM

WIRING DIAGRAM

Figure 67 is a complete wiring diagram for the furnace

A wiring diagram is also available on the unit.

FIGURE 67
SINGLE STAGE 90+ FURNACE DIAGRAM

